

GigaDevice Semiconductor Inc.

GD32F207xx

ARM[®] Cortex[®]-M3 32-bit MCU

Datasheet

Revision 2.7

(Jan. 2024)

Table of Contents

Table of Contents	1
List of Figures	4
List of Tables	5
1. General description	7
2. Device overview	8
2.1. Device information	8
2.2. Block diagram.....	11
2.3. Pinouts and pin assignment	12
2.4. Memory map	16
2.5. Clock tree	19
2.6. Pin definitions.....	20
2.6.1. GD32F207Ix LQFP176 pin definitions.....	20
2.6.2. GD32F207Zx LQFP144 pin definitions.....	31
2.6.3. GD32F207Vx LQFP100 pin definitions	40
2.6.4. GD32F207Rx LQFP64 pin definitions	47
3. Functional description	52
3.1. ARM® Cortex®-M3 core	52
3.2. On-chip memory	52
3.3. Clock, reset and supply management.....	53
3.4. Boot modes.....	53
3.5. Power saving modes	54
3.6. Analog to digital converter (ADC)	54
3.7. Digital to analog converter (DAC).....	55
3.8. DMA.....	55
3.9. General-purpose inputs/outputs (GPIOs)	55
3.10. Timers and PWM generation	56
3.11. Real time clock (RTC) and backup registers	57
3.12. Inter-integrated circuit (I2C)	57
3.13. Serial peripheral interface (SPI)	58
3.14. Universal synchronous/asynchronous receiver transmitter (USART/UART)	58

3.15.	Inter-IC sound (I2S)	58
3.16.	Universal serial bus full-speed interface (USBFS).....	59
3.17.	Controller area network (CAN)	59
3.18.	Ethernet (ENET).....	59
3.19.	External memory controller (EXMC)	60
3.20.	Secure digital input and output card interface (SDIO).....	60
3.21.	TFT LCD interface (TLI).....	60
3.22.	Digital camera interface (DCI).....	61
3.23.	Cryptographic acceleration Unit (CAU)	61
3.24.	Hash acceleration unit (HAU)	61
3.25.	True Random number generator (TRNG).....	62
3.26.	Debug mode	62
3.27.	Package and operation temperature.....	62
4.	Electrical characteristics.....	63
4.1.	Absolute maximum ratings.....	63
4.2.	Recommended DC characteristics	63
4.3.	Power consumption	65
4.4.	EMC characteristics	66
4.5.	Power supply supervisor characteristics	67
4.6.	Electrical sensitivity	67
4.7.	External clock characteristics	68
4.8.	Internal clock characteristics	70
4.9.	PLL characteristics.....	71
4.10.	Memory characteristics	71
4.11.	NRST pin characteristics	71
4.12.	GPIO characteristics	72
4.13.	ADC characteristics	74
4.14.	Temperature sensor characteristics.....	75
4.15.	DAC characteristics	75
4.16.	I2C characteristics	76
4.17.	SPI characteristics	77
4.18.	I2S characteristics.....	79

4.19.	USART characteristics.....	81
4.20.	SDIO characteristics	81
4.21.	CAN characteristics	81
4.22.	USBFS characteristics.....	82
4.23.	EXMC characteristics.....	83
4.24.	TIMER characteristics.....	86
4.25.	DCI characteristics.....	87
4.26.	WDGT characteristics	87
4.27.	Parameter conditions.....	88
5.	Package information.....	89
5.1.	LQFP176 package outline dimensions.....	89
5.2.	LQFP144 package outline dimensions.....	91
5.3.	LQFP100 package outline dimensions.....	93
5.4.	LQFP64 package outline dimensions.....	95
5.5.	Thermal characteristics	97
6.	Ordering information	99
7.	Revision history	100

List of Figures

Figure 2-1. GD32F207xx block diagram	11
Figure 2-2. GD32F2071x LQFP176 pinouts	12
Figure 2-3. GD32F207Zx LQFP144 pinouts	13
Figure 2-4. GD32F207Vx LQFP100 pinouts	14
Figure 2-5. GD32F207Rx LQFP64 pinouts	15
Figure 2-6. GD32F207xx clock tree	19
Figure 4-1. Recommended power supply decoupling capacitors ⁽¹⁾⁽²⁾	64
Figure 4-3. I2C bus timing diagram	77
Figure 4-4. SPI timing diagram - master mode	78
Figure 4-5. SPI timing diagram - slave mode	78
Figure 4-6. I2S timing diagram - master mode	80
Figure 4-7. I2S timing diagram - slave mode	80
Figure 4-8. USBFS timings: definition of data signal rise and fall time	82
Figure 5-1. LQFP176 package outline	89
Figure 5-2. LQFP176 recommended footprint	90
Figure 5-3. LQFP144 package outline	91
Figure 5-4. LQFP144 recommended footprint	92
Figure 5-5. LQFP100 package outline	93
Figure 5-6. LQFP100 recommended footprint	94
Figure 5-7. LQFP64 package outline	95
Figure 5-8. LQFP64 recommended footprint	96

List of Tables

Table 2-1. GD32F207xx devices features and peripheral list.....	8
Table 2-2. GD32F207xx memory map.....	16
Table 2-3. GD32F207Ix LQFP176 pin definitions.....	20
Table 2-4. GD32F207Zx LQFP144 pin definitions.....	31
Table 2-5. GD32F207Vx LQFP100 pin definitions.....	40
Table 2-6. GD32F207Rx LQFP64 pin definitions.....	47
Table 4-1. Absolute maximum ratings ⁽¹⁾⁽⁴⁾	63
Table 4-2. DC operating conditions.....	63
Table 4-3. Clock frequency ⁽¹⁾	64
Table 4-4. Operating conditions at Power up/ Power down ⁽¹⁾	64
Table 4-5. Start-up timings of Operating conditions ⁽¹⁾⁽²⁾⁽³⁾	64
Table 4-6. Power saving mode wakeup timings characteristics ⁽¹⁾⁽²⁾	65
Table 4-7. Power consumption characteristics.....	65
Table 4-8. EMS characteristics ⁽¹⁾	66
Table 4-9. Power supply supervisor characteristics.....	67
Table 4-10. ESD characteristics.....	68
Table 4-11. Static latch-up characteristics.....	68
Table 4-12. High speed external clock (HXTAL) generated from a crystal/ceramic characteristics.....	68
Table 4-13. High speed external clock characteristics (HXTAL in bypass mode).....	68
Table 4-14. Low speed external clock (LXTAL) generated from a crystal/ceramic characteristics ..	69
Table 4-15. Low speed external user clock characteristics (LXTAL in bypass mode).....	69
Table 4-16. High speed internal clock (IRC8M) characteristics.....	70
Table 4-17. Low speed internal clock (IRC40K) characteristics.....	70
Table 4-18. PLL characteristics.....	71
Table 4-19. Flash memory characteristics.....	71
Table 4-20. NRST pin characteristics.....	71
Table 4-21. I/O port DC characteristics ⁽¹⁾⁽³⁾	72
Table 4-22. I/O port AC characteristics ⁽¹⁾⁽²⁾⁽⁴⁾	74
Table 4-23. ADC characteristics.....	74
Table 4-24. ADC RAIN max for $f_{ADC} = 28 \text{ MHz}$ ⁽¹⁾⁽²⁾	75
Table 4-25. Temperature sensor characteristics ⁽¹⁾	75
Table 4-26. DAC characteristics.....	75
Table 4-27. I2C characteristics ⁽¹⁾⁽²⁾	76
Table 4-28. Standard SPI characteristics ⁽¹⁾	77
Table 4-29. I2S characteristics ⁽¹⁾⁽²⁾	79
Table 4-30. USART characteristics ⁽¹⁾	81
Table 4-31. SDIO characteristics ⁽¹⁾⁽²⁾	81
Table 4-32. USBFS start up time.....	82
Table 4-33. USBFS DC electrical characteristics.....	82
Table 4-34. USBFS full speed-electrical characteristics ⁽¹⁾	82

Table 4-35. Asynchronous non-multiplexed SRAM/PSRAM/NOR read timings ⁽¹⁾⁽²⁾⁽³⁾	83
Table 4-36. Asynchronous non-multiplexed SRAM/PSRAM/NOR write timings ⁽¹⁾⁽²⁾⁽³⁾	83
Table 4-37. Asynchronous multiplexed PSRAM/NOR read timings ⁽¹⁾⁽²⁾⁽³⁾	84
Table 4-38. Asynchronous multiplexed PSRAM/NOR write timings ⁽¹⁾⁽²⁾⁽³⁾	84
Table 4-39. Synchronous multiplexed PSRAM/NOR read timings ⁽¹⁾⁽²⁾⁽³⁾	85
Table 4-40. Synchronous multiplexed PSRAM write timings ⁽¹⁾⁽²⁾⁽³⁾	85
Table 4-41. Synchronous non-multiplexed PSRAM/NOR read timings ⁽¹⁾⁽²⁾⁽³⁾	86
Table 4-42. Synchronous non-multiplexed PSRAM write timings ⁽¹⁾⁽²⁾⁽³⁾	86
Table 4-43. TIMER characteristics ⁽¹⁾	86
Table 4-44. DCI characteristics ⁽¹⁾	87
Table 4-45. FWDGT min/max timeout period at 40 kHz (IRC40K) ⁽¹⁾	87
Table 4-46. WWDGT min-max timeout value at 60 MHz (f_{PCLK1}) ⁽¹⁾	87
Table 5-1. LQFP176 package dimensions	89
Table 5-2. LQFP144 package dimensions	91
Table 5-3. LQFP100 package dimensions	93
Table 5-4. LQFP64 package dimensions	95
Table 5-5. Package thermal characteristics ⁽¹⁾	97
Table 6-1. Part ordering code for GD32F207xx devices	99
Table 7-1. Revision history	100

1. General description

The GD32F207xx device belongs to the performance line of GD32 MCU Family. It is a new 32-bit general-purpose microcontroller based on the ARM® Cortex®-M3 RISC core with best cost-performance ratio in terms of processing capacity, reduced power consumption and peripheral set. The Cortex®-M3 is a next generation processor core which is tightly coupled with a Nested Vectored Interrupt Controller (NVIC), SysTick timer and advanced debug support.

The GD32F207xx device incorporates the ARM® Cortex®-M3 32-bit processor core operating at 120 MHz frequency with flash accesses zero wait states to obtain maximum efficiency. It provides up to 3072 KB on-chip flash memory and 256 KB SRAM memory. An extensive range of enhanced I/Os and peripherals connected to two APB buses. The devices offer up to three 12-bit 2 MSPS ADCs, two 12-bit DACs, up to ten 16-bit general timers, two 16-bit basic timers plus two 16-bit PWM advanced timers, as well as standard and advanced communication interfaces: up to three SPIs, three I2Cs, four USARTs and four UARTs, two I2Ss, two CANs, a SDIO, a USBFS and an Ethernet. Additional peripherals as TFT-LCD Interface (TLI), EXMC interface with SDRAM extension support, Digital camera interface (DCI), Cryptographic acceleration unit (CAU), Hash acceleration unit (HAU), True random number generator (TRNG) are included.

The device operates from a 2.6 to 3.6V power supply and available in –40 to +85 °C temperature range. Several power saving modes provide the flexibility for maximum optimization of power consumption, an especially important consideration in low power applications.

The above features make GD32F207xx devices suitable for a wide range of interconnection and advanced applications, especially in areas such as industrial control, consumer and handheld equipment, embedded modules, human machine interface, security and alarm systems, POS and electronic payment, automotive navigation and so on.



2. Device overview

2.1. Device information

Table 2-1. GD32F207xx devices features and peripheral list

Part Number		GD32F207xx							
		RC	RE	RG	RK	VC	VE	VG	VK
Flash	Code area (KB)	256	512	384	384	256	512	384	384
	Data area (KB)	0	0	640	2688	0	0	640	2688
	Total (KB)	256	512	1024	3072	256	512	1024	3072
SRAM (KB)		128	128	256	256	128	128	256	256
Timers	General timer(16-bit)	10 <small>(1-4,8-13)</small>	10 <small>(1-4,8-13)</small>	10 <small>(1-4,8-13)</small>	10 <small>(1-4,8-13)</small>	10 <small>(1-4,8-13)</small>	10 <small>(1-4,8-13)</small>	10 <small>(1-4,8-13)</small>	10 <small>(1-4,8-13)</small>
	Advanced timer (16-bit)	2 <small>(0,7)</small>	2 <small>(0,7)</small>	2 <small>(0,7)</small>	2 <small>(0,7)</small>	2 <small>(0,7)</small>	2 <small>(0,7)</small>	2 <small>(0,7)</small>	2 <small>(0,7)</small>
	SysTick	1	1	1	1	1	1	1	1
	Basic timer (16-bit)	2 <small>(5,6)</small>	2 <small>(5,6)</small>	2 <small>(5,6)</small>	2 <small>(5,6)</small>	2 <small>(5,6)</small>	2 <small>(5,6)</small>	2 <small>(5,6)</small>	2 <small>(5,6)</small>
	Watchdog	2	2	2	2	2	2	2	2
	RTC	1	1	1	1	1	1	1	1
Connectivity	USART	4	4	4	4	4	4	4	4
	UART	2 <small>(3-4)</small>	2 <small>(3-4)</small>	2 <small>(3-4)</small>	2 <small>(3-4)</small>	4 <small>(3-4,6-7)</small>	4 <small>(3-4,6-7)</small>	4 <small>(3-4,6-7)</small>	4 <small>(3-4,6-7)</small>
	I2C	3	3	3	3	3	3	3	3
	SPI/I2S	3/2 <small>(0-2)/(1-2)</small>	3/2 <small>(0-2)/(1-2)</small>	3/2 <small>(0-2)/(1-2)</small>	3/2 <small>(0-2)/(1-2)</small>	3/2 <small>(0-2)/(1-2)</small>	3/2 <small>(0-2)/(1-2)</small>	3/2 <small>(0-2)/(1-2)</small>	3/2 <small>(0-2)/(1-2)</small>
	SDIO	1	1	1	1	1	1	1	1
	CAN	2	2	2	2	2	2	2	2
	USBFS	1	1	1	1	1	1	1	1
	ENET	1	1	1	1	1	1	1	1
	TLI	0	0	0	0	1	1	1	1
	DCI	1	1	1	1	1	1	1	1
CAU/HAU	1	1	1	1	1	1	1	1	
GPIO		51	51	51	51	82	82	82	82
EXMC/SDRAM		0/0	0/0	0/0	0/0	1/0	1/0	1/0	1/0

Part Number	GD32F207xx							
	RC	RE	RG	RK	VC	VE	VG	VK
ADC (CHs)	3(16)	3(16)	3(16)	3(16)	3(16)	3(16)	3(16)	3(16)
DAC	2	2	2	2	2	2	2	2
Package	LQFP64				LQFP100			

Table 2-1. GD32F207xx devices features and peripheral list (continued)

Part Number		GD32F207xx						
		ZC	ZE	ZG	ZK	IE	IG	IK
Flash	Code area (KB)	256	512	384	384	512	384	384
	Data area (KB)	0	0	640	2688	0	640	2688
	Total (KB)	256	512	1024	3072	512	1024	3072
SRAM (KB)		128	128	256	256	128	256	256
Timers	General timer (16-bit)	10 <small>(1-4,8-13)</small>	10 <small>(1-4,8-13)</small>	10 <small>(1-4,8-13)</small>	10 <small>(1-4,8-13)</small>	10 <small>(1-4,8-13)</small>	10 <small>(1-4,8-13)</small>	10 <small>(1-4,8-13)</small>
	Advanced timer (16-bit)	2 <small>(0,7)</small>	2 <small>(0,7)</small>	2 <small>(0,7)</small>	2 <small>(0,7)</small>	2 <small>(0,7)</small>	2 <small>(0,7)</small>	2 <small>(0,7)</small>
	SysTick	1	1	1	1	1	1	1
	Basic timer (16-bit)	2 <small>(5,6)</small>	2 <small>(5,6)</small>	2 <small>(5,6)</small>	2 <small>(5,6)</small>	2 <small>(5,6)</small>	2 <small>(5,6)</small>	2 <small>(5,6)</small>
	Watchdog	2	2	2	2	2	2	2
	RTC	1	1	1	1	1	1	1
Connectivity	USART	4	4	4	4	4	4	4
	UART	4	4	4	4	4	4	4
	I2C	3	3	3	3	3	3	3
	SPI/I2S	3/2	3/2	3/2	3/2	3/2	3/2	3/2
	SDIO	1	1	1	1	1	1	1
	CAN	2	2	2	2	2	2	2
	USBFS	1	1	1	1	1	1	1
	ENET	1	1	1	1	1	1	1
	TLI	1	1	1	1	1	1	1
	DCI	1	1	1	1	1	1	1
CAU/HAU	1	1	1	1	1	1	1	
GPIO		114	114	114	114	140	140	140

Part Number	GD32F207xx						
	ZC	ZE	ZG	ZK	IE	IG	IK
EXMC/SDRAM	1/1	1/1	1/1	1/1	1/1	1/1	1/1
ADC (CHs)	3(24)	3(24)	3(24)	3(24)	3(24)	3(24)	3(24)
DAC	2	2	2	2	2	2	2
Package	LQFP144				LQFP176		

2.3. Pinouts and pin assignment

Figure 2-2. GD32F2071x LQFP176 pinouts



Figure 2-3. GD32F207Zx LQFP144 pinouts



Figure 2-5. GD32F207Rx LQFP64 pinouts

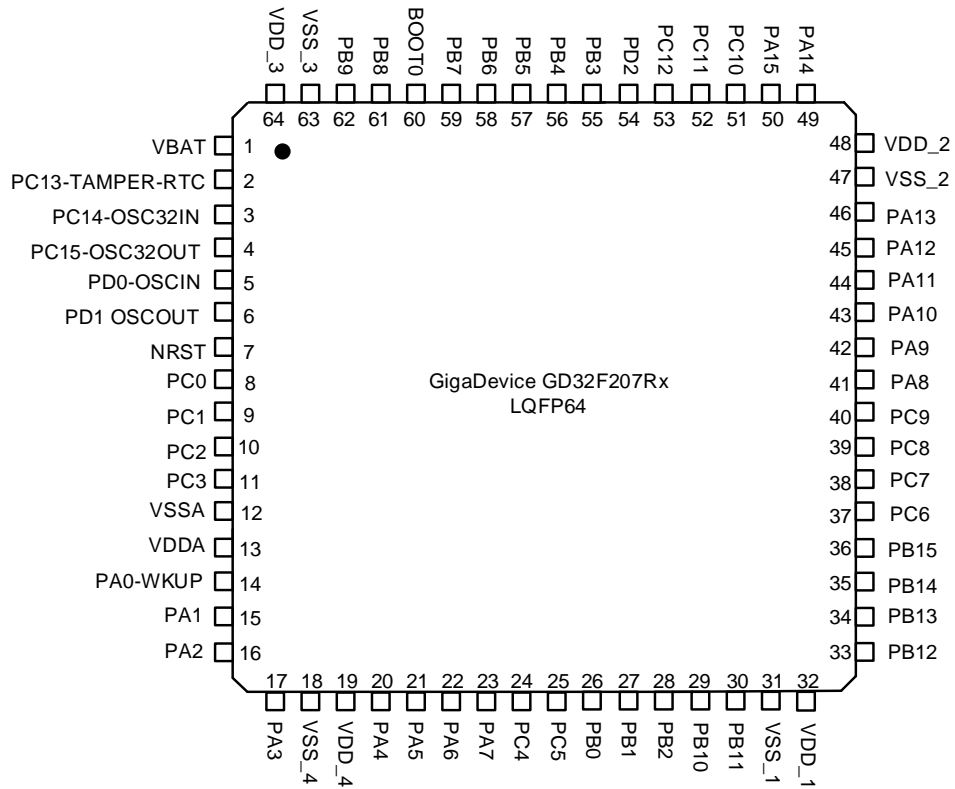

2.4. Memory map

Table 2-2. GD32F207xx memory map

Pre-defined Regions	Bus	Address	Peripherals	
External Device	AHB	0xC000 0000 - 0xDFFF FFFF	EXMC - SDRAM	
		0xA000 1000 - 0xBFFF FFFF	Reserved	
		0xA000 0000 - 0xA000 0FFF	EXMC - SWREG	
		0x9000 0000 - 0x9FFF FFFF	EXMC - PC CARD	
		0x7000 0000 - 0x8FFF FFFF	EXMC - NAND	
		0x6000 0000 - 0x6FFF FFFF	EXMC - NOR/PSRAM/SRAM	
External RAM	AHB	0x5006 0C00 - 0x5FFF FFFF	Reserved	
		0x5006 0800 - 0x5006 0BFF	TRNG	
Peripheral	AHB2	0x 5006 0400 – 0x5006 07FF	HAU	
		0x 5006 0000 – 0x5006 03FF	CAU	
		0x5005 0400 - 0x5005 FFFF	Reserved	
		0x5005 0000 - 0x5005 03FF	DCI	
		0x5004 0000 - 0x5004 FFFF	Reserved	
		AHB1	0x5000 0000 - 0x5003 FFFF	USBFS
			0x4002 A000 - 0x4FFF FFFF	Reserved
	0x4002 8000 - 0x4002 9FFF		ENET	
	0x4002 3400 - 0x4002 7FFF		Reserved	
	0x4002 3000 - 0x4002 33FF		CRC	
	0x4002 2400 - 0x4002 2FFF		Reserved	
	0x4002 2000 - 0x4002 23FF		FMC	
	0x4002 1400 - 0x4002 1FFF		Reserved	
	0x4002 1000 - 0x4002 13FF		RCU	
	0x4002 0800 - 0x4002 0FFF		Reserved	
	0x4002 0400 - 0x4002 07FF		DMA0	
	0x4002 0000 - 0x4002 03FF		DMA1	
	0x4001 8400 - 0x4001 FFFF		Reserved	
	0x4001 8000 - 0x4001 83FF	SDIO		
	APB2	0x4001 7C00 - 0x4001 7FFF	Reserved	
		0x4001 7800 - 0x4001 7BFF	GPIOI	
		0x4001 7400 - 0x4001 77FF	GPIOH	
		0x4001 7000 - 0x4001 73FF	USART5	
		0x4001 6C00 - 0x4001 6FFF	Reserved	
		0x4001 6800 - 0x4001 6BFF	TLI	
		0x4001 5800 - 0x4001 67FF	Reserved	
		0x4001 5400 - 0x4001 57FF	TIMER10	
		0x4001 5000 - 0x4001 53FF	TIMER9	
		0x4001 4C00 - 0x4001 4FFF	TIMER8	

Pre-defined Regions	Bus	Address	Peripherals	
		0x4001 4000 - 0x4001 4BFF	Reserved	
		0x4001 3C00 - 0x4001 3FFF	ADC2	
		0x4001 3800 - 0x4001 3BFF	USART0	
		0x4001 3400 - 0x4001 37FF	TIMER7	
		0x4001 3000 - 0x4001 33FF	SPI0	
		0x4001 2C00 - 0x4001 2FFF	TIMER0	
		0x4001 2800 - 0x4001 2BFF	ADC1	
		0x4001 2400 - 0x4001 27FF	ADC0	
		0x4001 2000 - 0x4001 23FF	GPIOG	
		0x4001 1C00 - 0x4001 1FFF	GPIOF	
		0x4001 1800 - 0x4001 1BFF	GPIOE	
		0x4001 1400 - 0x4001 17FF	GPIOD	
		0x4001 1000 - 0x4001 13FF	GPIOC	
		0x4001 0C00 - 0x4001 0FFF	GPIOB	
		0x4001 0800 - 0x4001 0BFF	GPIOA	
		0x4001 0400 - 0x4001 07FF	EXTI	
	0x4001 0000 - 0x4001 03FF	AFIO		
	APB1		0x4000 C400 - 0x4000 FFFF	Reserved
			0x4000 C000 - 0x4000 C3FF	I2C2
			0x4000 8000 - 0x4000 BFFF	Reserved
			0x4000 7C00 - 0x4000 7FFF	UART7
			0x4000 7800 - 0x4000 7BFF	UART6
			0x4000 7400 - 0x4000 77FF	DAC
			0x4000 7000 - 0x4000 73FF	PMU
			0x4000 6C00 - 0x4000 6FFF	BKP
			0x4000 6800 - 0x4000 6BFF	CAN1
			0x4000 6400 - 0x4000 67FF	CAN0
			0x4000 5C00 - 0x4000 63FF	USB/CAN shared
			0x4000 5800 - 0x4000 5BFF	I2C1
			0x4000 5400 - 0x4000 57FF	I2C0
			0x4000 5000 - 0x4000 53FF	UART4
			0x4000 4C00 - 0x4000 4FFF	UART3
			0x4000 4800 - 0x4000 4BFF	USART2
			0x4000 4400 - 0x4000 47FF	USART1
			0x4000 4000 - 0x4000 43FF	Reserved
			0x4000 3C00 - 0x4000 3FFF	SPI2/I2S2
0x4000 3800 - 0x4000 3BFF			SPI1/I2S1	
0x4000 3400 - 0x4000 37FF	Reserved			
0x4000 3000 - 0x4000 33FF	FWDGT			
0x4000 2C00 - 0x4000 2FFF	WWDGT			

Pre-defined Regions	Bus	Address	Peripherals
		0x4000 2800 - 0x4000 2BFF	RTC
		0x4000 2400 - 0x4000 27FF	Reserved
		0x4000 2000 - 0x4000 23FF	TIMER13
		0x4000 1C00 - 0x4000 1FFF	TIMER12
		0x4000 1800 - 0x4000 1BFF	TIMER11
		0x4000 1400 - 0x4000 17FF	TIMER6
		0x4000 1000 - 0x4000 13FF	TIMER5
		0x4000 0C00 - 0x4000 0FFF	TIMER4
		0x4000 0800 - 0x4000 0BFF	TIMER3
		0x4000 0400 - 0x4000 07FF	TIMER2
		0x4000 0000 - 0x4000 03FF	TIMER1
SRAM	AHB	0x2004 0000 - 0x3FFF FFFF	Reserved
		0x2002 0000 - 0x2003 FFFF	SRAM2(128KB)
		0x2001 C000 - 0x2001 FFFF	SRAM1(16KB)
		0x2000 0000 - 0x2001 BFFF	SRAM0(112KB)
Code	AHB	0x1FFF F810 - 0x1FFF FFFF	Reserved
		0x1FFF F800 - 0x1FFF F80F	Option Bytes
		0x1FFF B000 - 0x1FFF F7FF	System memory
		0x0830 0000 - 0x1FFF AFFF	Reserved
		0x0800 0000 - 0x082F FFFF	Main Flash(3072KB)
		0x0000 0000 - 0x07FF FFFF	Aliased to Flash or system memory according to BOOT pins configuration

2.5. Clock tree

Figure 2-6. GD32F207xx clock tree

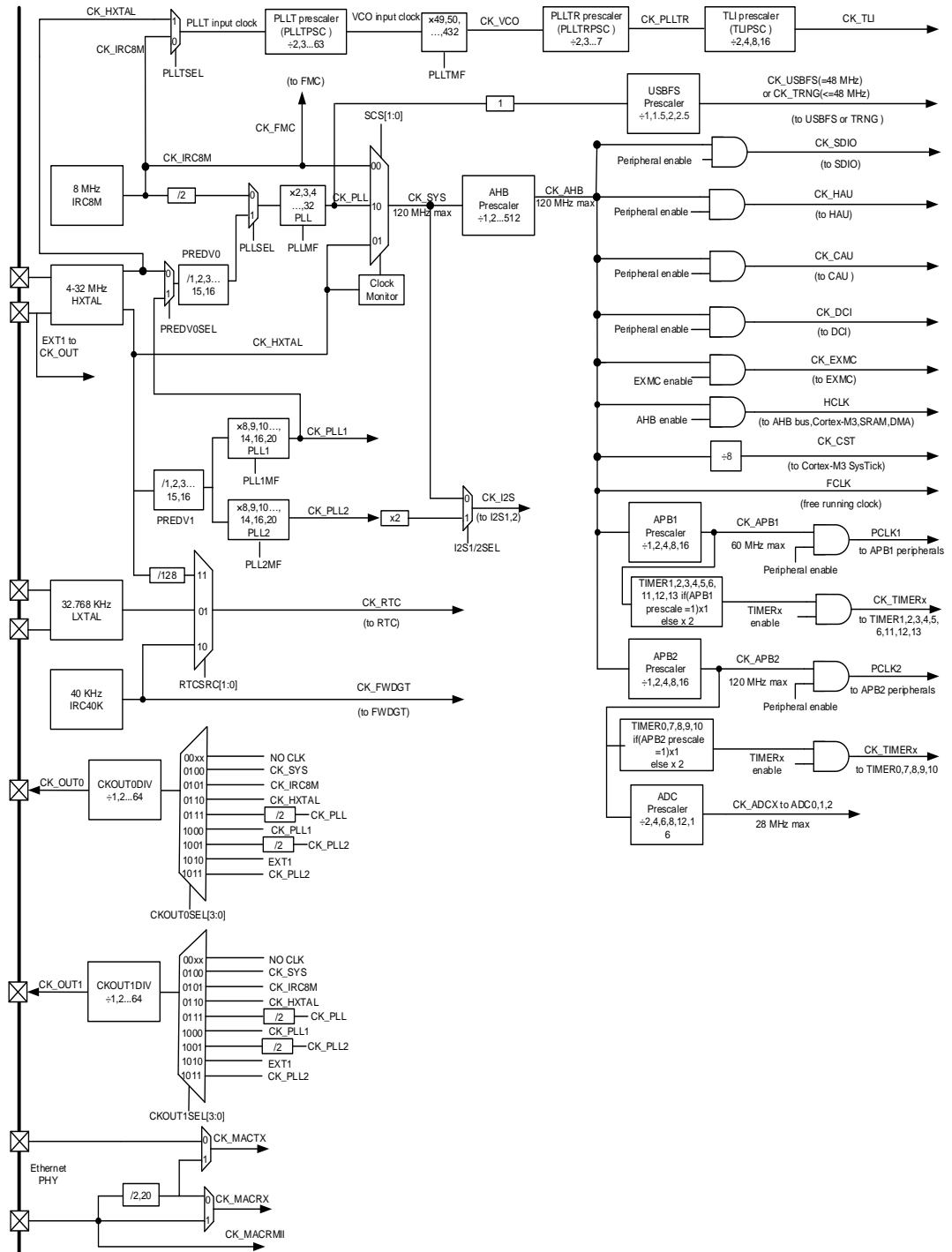

Legend:

- HXTAL: High speed crystal oscillator
- LXTAL: Low speed crystal oscillator
- IRC8M: Internal 8M RC oscillators
- IRC40K: Internal 40K RC oscillator

2.6. Pin definitions

2.6.1. GD32F207Ix LQFP176 pin definitions

Table 2-3. GD32F207Ix LQFP176 pin definitions

GD32F207Ix LQFP176				
Pin Name	Pins	Pin Type ⁽¹⁾	I/O Level ⁽²⁾	Functions description
PE2	1	I/O	5VT	Default: PE2 Alternate: TRACECK, EXMC_A23 Remap: ETH_MII_TXD3
PE3	2	I/O	5VT	Default: PE3 Alternate: TRACED0, EXMC_A19
PE4	3	I/O	5VT	Default: PE4 Alternate: TRACED1, EXMC_A20 Remap: DCI_D4, TLI_B0
PE5	4	I/O	5VT	Default: PE5 Alternate: TRACED2, EXMC_A21 Remap: TIMER8_CH0, DCI_D6, TLI_G0
PE6	5	I/O	5VT	Default: PE6 Alternate: TRACED3, EXMC_A22 Remap: TIMER8_CH1, DCI_D7, TLI_G1
VBAT	6	P		Default: VBAT
PI8	7	I/O		Default: PI8
PC13-TAMPER-RTC	8	I/O	5VT	Default: PC13 Alternate: TAMPER-RTC
PC14-OSC32IN	9	I/O		Default: PC14 Alternate: OSC32IN
PC15-OSC32OUT	10	I/O		Default: PC15 Alternate: OSC32OUT
PI9	11	I/O	5VT	Default: PI9 Alternate: EXMC_D30 Remap: TLI_VSYNC, CAN0_RX
PI10	12	I/O	5VT	Default: PI10 Alternate: EXMC_D31 Remap: TLI_HSYNC, ETH_MII_RX_ER
PI11	13	I/O	5VT	Default: PI11
VSS	14	P		Default: VSS
VDD	15	P		Default: VDD
PF0	16	I/O	5VT	Default: PF0 Alternate: EXMC_A0 Remap: I2C1_SDA

GD32F2071x LQFP176				
Pin Name	Pins	Pin Type ⁽¹⁾	I/O Level ⁽²⁾	Functions description
PF1	17	I/O	5VT	Default: PF1 Alternate: EXMC_A1 Remap: I2C1_SCL
PF2	18	I/O	5VT	Default: PF2 Alternate: EXMC_A2 Remap: I2C1_SMBA
PF3	19	I/O	5VT	Default: PF3 Alternate: EXMC_A3, ADC2_IN9
PF4	20	I/O	5VT	Default: PF4 Alternate: EXMC_A4, ADC2_IN14
PF5	21	I/O	5VT	Default: PF5 Alternate: EXMC_A5, ADC2_IN15
VSS_5	22	P		Default: VSS_5
VDD_5	23	P		Default: VDD_5
PF6	24	I/O		Default: PF6 Alternate: ADC2_IN4, EXMC_NIORD Remap: TIMER9_CH0, UART6_RX
PF7	25	I/O		Default: PF7 Alternate: ADC2_IN5, EXMC_NREG Remap: TIMER10_CH0, UART6_TX
PF8	26	I/O		Default: PF8 Alternate: ADC2_IN6, EXMC_NIOWR Remap: TIMER12_CH0
PF9	27	I/O		Default: PF9 Alternate: ADC2_IN7, EXMC_CD Remap: TIMER13_CH0
PF10	28	I/O		Default: PF10 Alternate: ADC2_IN8, EXMC_INTR Remap: DCI_D11, TLI_DE
OSCIN	29	I		Default: OSCIN Remap: PD0, PH0
OSCO UT	30	O		Default: OSCOUT Remap: PD1, PH1
NRST	31	I/O		Default: NRST
PC0	32	I/O		Default: PC0 Alternate: ADC012_IN10 Remap: EXMC_SDNWE
PC1	33	I/O		Default: PC1 Alternate: ADC012_IN11, ETH_MDC
PC2	34	I/O		Default: PC2 Alternate: ADC012_IN12, ETH_MII_TXD2 Remap: EXMC_SDNE0, SPI1_MISO
PC3	35	I/O		Default: PC3 Alternate: ADC012_IN13, ETH_MII_TX_CLK

GD32F2071x LQFP176				
Pin Name	Pins	Pin Type ⁽¹⁾	I/O Level ⁽²⁾	Functions description
				Remap: EXMC_SDCKE0, SPI1_MOSI, I2S1_SD
VSSA	36	P		Default: VSSA
VREFN	37	P		Default: VREFN
VREFFP	38	P		Default: VREFFP
VDDA	39	P		Default: VDDA
PA0-WKUP	40	I/O		Default: PA0 Alternate: WKUP, USART1_CTS, ADC012_IN0, TIMER1_CH0, TIMER1_ETI, TIMER4_CH0, TIMER7_ETI, ETH_MII_CRS Remap: UART3_TX
PA1	41	I/O		Default: PA1 Alternate: USART1_RTS, ADC012_IN1, TIMER1_CH1, TIMER4_CH1, ETH_MII_RX_CLK, ETH_RMII_REF_CLK Remap: UART3_RX
PA2	42	I/O		Default: PA2 Alternate: USART1_TX, ADC012_IN2, TIMER1_CH2, TIMER4_CH2, TIMER8_CH0, ETH_MDIO, SPI0_IO3
PH2	43	I/O	5VT	Default: PH2 Alternate: EXMC_SDCKE0 Remap: TLI_R0, ETH_MII_CRS
PH3	44	I/O	5VT	Default: PH3 Alternate: EXMC_SDNE0 Remap: TLI_R1, ETH_MII_COL
PH4	45	I/O	5VT	Default: PH4 Remap: I2C1_SCL, TLI_R0
PH5	46	I/O	5VT	Default: PH5 Alternate: EXMC_SDNWE Remap: I2C1_SDA
PA3	47	I/O		Default: PA3 Alternate: USART1_RX, ADC012_IN3, TIMER1_CH3, TIMER4_CH3, TIMER8_CH1, ETH_MII_COL, SPI0_IO4 Remap: TLI_B5
VSS_4	48	P		Default: VSS_4
VDD_4	49	P		Default: VDD_4
PA4	50	I/O		Default: PA4 Alternate: SPI0_NSS, USART1_CK, DAC_OUT0, ADC01_IN4, DCI_HSYNC Remap: SPI2_NSS, I2S2_WS, TLI_VSYNC
PA5	51	I/O		Default: PA5 Alternate: SPI0_SCK, ADC01_IN5, DAC_OUT1 Remap: TIMER1_CH0, TIMER1_ETI, TIMER7_CH0_ON
PA6	52	I/O		Default: PA6 Alternate: SPI0_MISO, ADC01_IN6, TIMER2_CH0, TIMER7_BRKIN, TIMER12_CH0, DCI_PIXCLK Remap: TIMER0_BRKIN, TLI_G2

GD32F2071x LQFP176				
Pin Name	Pins	Pin Type ⁽¹⁾	I/O Level ⁽²⁾	Functions description
PA7	53	I/O		Default: PA7 Alternate: SPI0_MOSI, ADC01_IN7, TIMER2_CH1, TIMER7_CH0_ON, TIMER13_CH0, ETH_MII_RX_DV, ETH_RMII_CRS_DV Remap: TIMER0_CH0_ON
PC4	54	I/O		Default: PC4 Alternate: ADC01_IN14, ETH_MII_RXD0, ETH_RMII_RXD0
PC5	55	I/O		Default: PC5 Alternate: ADC01_IN15, ETH_MII_RXD1, ETH_RMII_RXD1
PB0	56	I/O		Default: PB0 Alternate: ADC01_IN8, TIMER2_CH2, TIMER7_CH1_ON, ETH_MII_RXD2 Remap: TIMER0_CH1_ON, TLI_R3
PB1	57	I/O		Default: PB1 Alternate: ADC01_IN9, TIMER2_CH3, TIMER7_CH2_ON, ETH_MII_RXD3 Remap: TIMER0_CH2_ON, TLI_R6
PB2	58	I/O	5VT	Default: PB2, BOOT1
PF11	59	I/O	5VT	Default: PF11 Alternate: EXMC_NIOS16, DCI_D12, EXMC_SDNRAS
PF12	60	I/O	5VT	Default: PF12 Alternate: EXMC_A6
VSS_6	61	P		Default: VSS_6
VDD_6	62	P		Default: VDD_6
PF13	63	I/O	5VT	Default: PF13 Alternate: EXMC_A7
PF14	64	I/O	5VT	Default: PF14 Alternate: EXMC_A8
PF15	65	I/O	5VT	Default: PF15 Alternate: EXMC_A9
PG0	66	I/O	5VT	Default: PG0 Alternate: EXMC_A10
PG1	67	I/O	5VT	Default: PG1 Alternate: EXMC_A11
PE7	68	I/O	5VT	Default: PE7 Alternate: EXMC_D4, UART6_RX Remap: TIMER0_ETI
PE8	69	I/O	5VT	Default: PE8 Alternate: EXMC_D5, UART6_TX Remap: TIMER0_CH0_ON
PE9	70	I/O	5VT	Default: PE9 Alternate: EXMC_D6 Remap: TIMER0_CH0
VSS_7	71	P		Default: VSS_7

GD32F207xx LQFP176				
Pin Name	Pins	Pin Type ⁽¹⁾	I/O Level ⁽²⁾	Functions description
VDD_7	72	P		Default: VDD_7
PE10	73	I/O	5VT	Default: PE10 Alternate: EXMC_D7 Remap: TIMER0_CH1_ON
PE11	74	I/O	5VT	Default: PE11 Alternate: EXMC_D8 Remap: TIMER0_CH1, TLI_G3
PE12	75	I/O	5VT	Default: PE12 Alternate: EXMC_D9 Remap: TIMER0_CH2_ON, TLI_B4
PE13	76	I/O	5VT	Default: PE13 Alternate: EXMC_D10 Remap: TIMER0_CH2, TLI_DE
PE14	77	I/O	5VT	Default: PE14 Alternate: EXMC_D11 Remap: TIMER0_CH3, TLI_PIXCLK
PE15	78	I/O	5VT	Default: PE15 Alternate: EXMC_D12 Remap: TIMER0_BRKIN, TLI_R7
PB10	79	I/O	5VT	Default: PB10 Alternate: I2C1_SCL, USART2_TX, ETH_MII_RX_ER Remap: TIMER1_CH2, TLI_G4, SPI1_SCK, I2S1_CK
PB11	80	I/O	5VT	Default: PB11 Alternate: I2C1_SDA, USART2_RX, ETH_MII_TX_EN, ETH_RMII_TX_EN Remap: TIMER1_CH3, TLI_G5
VSS_1	81	P		Default: VSS_1
VDD_1	82	P		Default: VDD_1
PH6	83	I/O	5VT	Default: PH6 Alternate: EXMC_SDNE1 Remap: I2C1_SMBA, TIMER11_CH0, ETH_MII_RXD2, DCI_D8
PH7	84	I/O	5VT	Default: PH7 Alternate: EXMC_SDCKE1 Remap: I2C2_SCL, ETH_MII_RXD3, DCI_D9
PH8	85	I/O	5VT	Default: PH8 Alternate: EXMC_D16 Remap: TLI_R2, I2C2_SDA, DCI_HSYNC
PH9	86	I/O	5VT	Default: PH9 Alternate: EXMC_D17 Remap: TLI_R3, I2C2_SMBA, TIMER11_CH1, DCI_D0
PH10	87	I/O	5VT	Default: PH10 Alternate: EXMC_D18 Remap: TLI_R4, TIMER4_CH0, DCI_D1
PH11	88	I/O	5VT	Default: PH11

GD32F207xx LQFP176				
Pin Name	Pins	Pin Type ⁽¹⁾	I/O Level ⁽²⁾	Functions description
				Alternate: EXMC_D19 Remap: TLI_R5, TIMER4_CH1, DCI_D2
PH12	89	I/O	5VT	Default: PH12 Alternate: EXMC_D20 Remap: TLI_R6, TIMER4_CH2, DCI_D3
VSS	90	P		Default: VSS
VDD	91	P		Default: VDD
PB12	92	I/O	5VT	Default: PB12 Alternate: SPI1_NSS, I2C1_SMBA, USART2_CK, TIMER0_BRKIN, I2S1_WS, CAN1_RX, ETH_MII_TXD0, ETH_RMII_TXD0
PB13	93	I/O	5VT	Default: PB13 Alternate: SPI1_SCK, USART2_CTS, TIMER0_CH0_ON, I2S1_CK, CAN1_TX, ETH_MII_TXD1, ETH_RMII_TXD1
PB14	94	I/O	5VT	Default: PB14 Alternate: SPI1_MISO, USART2_RTS, TIMER0_CH1_ON, TIMER11_CH0
PB15	95	I/O	5VT	Default: PB15 Alternate: SPI1_MOSI, TIMER0_CH2_ON, I2S1_SD, TIMER11_CH1
PD8	96	I/O	5VT	Default: PD8 Alternate: EXMC_D13 Remap: USART2_TX, ETH_MII_RX_DV, ETH_RMII_CRS_DV
PD9	97	I/O	5VT	Default: PD9 Alternate: EXMC_D14 Remap: USART2_RX, ETH_MII_RXD0, ETH_RMII_RXD0
PD10	98	I/O	5VT	Default: PD10 Alternate: EXMC_D15 Remap: USART2_CK, ETH_MII_RXD1, ETH_RMII_RXD1, TLI_B3
PD11	99	I/O	5VT	Default: PD11 Alternate: EXMC_A16/EXMC_CLE Remap: USART2_CTS, ETH_MII_RXD2
PD12	100	I/O	5VT	Default: PD12 Alternate: EXMC_A17/EXMC_ALE Remap: TIMER3_CH0, USART2_RTS
PD13	101	I/O	5VT	Default: PD13 Alternate: EXMC_A18 Remap: TIMER3_CH1
VSS_8	102	P		Default: VSS_8
VDD_8	103	P		Default: VDD_8
PD14	104	I/O	5VT	Default: PD14 Alternate: EXMC_D0 Remap: TIMER3_CH2
PD15	105	I/O	5VT	Default: PD15 Alternate: EXMC_D1

GD32F2071x LQFP176				
Pin Name	Pins	Pin Type ⁽¹⁾	I/O Level ⁽²⁾	Functions description
				Remap: TIMER3_CH3
PG2	106	I/O	5VT	Default: PG2 Alternate: EXMC_A12
PG3	107	I/O	5VT	Default: PG3 Alternate: EXMC_A13
PG4	108	I/O	5VT	Default: PG4 Alternate: EXMC_A14, EXMC_BA0
PG5	109	I/O	5VT	Default: PG5 Alternate: EXMC_A15, EXMC_BA1
PG6	110	I/O	5VT	Default: PG6 Alternate: EXMC_INT1 Remap: DCI_D12, TLI_R7
PG7	111	I/O	5VT	Default: PG7 Alternate: EXMC_INT2, DCI_D13 Remap: USART5_CK, TLI_PIXCLK
PG8	112	I/O	5VT	Default: PG8 Alternate: EXMC_SDCLK, USART5_RTS Remap: ETH_PPS_OUT
VSS_9	113	P		Default: VSS_9
VDD_9	114	P		Default: VDD_9
PC6	115	I/O	5VT	Default: PC6 Alternate: I2S1_MCK, TIMER7_CH0, SDIO_D6, USART5_TX Remap: TIMER2_CH0, DCI_D0, TLI_HSYNC
PC7	116	I/O	5VT	Default: PC7 Alternate: I2S2_MCK, TIMER7_CH1, SDIO_D7, USART5_RX Remap: TIMER2_CH1, DCI_D1, TLI_G6
PC8	117	I/O	5VT	Default: PC8 Alternate: TIMER7_CH2, SDIO_D0, DCI_D2, USART5_CK Remap: TIMER2_CH2
PC9	118	I/O	5VT	Default: PC9 Alternate: TIMER7_CH3, SDIO_D1, DCI_D3, CK_OUT1 Remap: TIMER2_CH3, I2C2_SDA
PA8	119	I/O	5VT	Default: PA8 Alternate: USART0_CK, TIMER0_CH0, CK_OUT0, VCORE, USBFS_SOF Remap: TLI_R6, I2C2_SCL
PA9	120	I/O	5VT	Default: PA9 Alternate: USART0_TX, TIMER0_CH1, USBFS_VBUS, DCI_D0 Remap: I2C2_SMBAI
PA10	121	I/O	5VT	Default: PA10 Alternate: USART0_RX, TIMER0_CH2, USBFS_ID, DCI_D1
PA11	122	I/O	5VT	Default: PA11 Alternate: USART0_CTS, CAN0_RX, USBFS_DM, TIMER0_CH3 Remap: TLI_R4

GD32F2071x LQFP176				
Pin Name	Pins	Pin Type ⁽¹⁾	I/O Level ⁽²⁾	Functions description
PA12	123	I/O	5VT	Default: PA12 Alternate: USART0_RTS, USBFS_DP, CAN0_TX, TIMER0_ETI Remap: TLI_R5
PA13	124	I/O	5VT	Default: JTMS, SWDIO Remap: PA13
NC	125			-
VSS_2	126	P		Default: VSS_2
VDD_2	127	P		Default: VDD_2
PH13	128	I/O	5VT	Default: PH13 Alternate: EXMC_D21 Remap: TLI_G2, TIMER7_CH0_ON, CAN0_TX
PH14	129	I/O	5VT	Default: PH14 Alternate: EXMC_D22 Remap: TLI_G3, TIMER7_CH1_ON, DCI_D4
PH15	130	I/O	5VT	Default: PH15 Alternate: EXMC_D23 Remap: TLI_G4, TIMER7_CH2_ON, DCI_D11
PI0	131	I/O	5VT	Default: PI0 Alternate: EXMC_D24 Remap: TLI_G5, TIMER4_CH3, SPI1_NSS, I2S1_WS, DCI_D13
PI1	132	I/O	5VT	Default: PI1 Alternate: EXMC_D25 Remap: TLI_G6, SPI1_SCK, I2S1_CK, DCI_D8
PI2	133	I/O	5VT	Default: PI2 Alternate: EXMC_D26 Remap: TLI_G7, TIMER7_CH3, SPI1_MISO, DCI_D9
PI3	134	I/O	5VT	Default: PI3 Alternate: EXMC_D27 Remap: TIMER7_ETI, SPI1_MOSI, I2S1_SD, TLI_R1, DCI_D10
VSS	135	P		Default: VSS
VDD	136	P		Default: VDD
PA14	137	I/O	5VT	Default: JTCK, SWCLK Remap: PA14
PA15	138	I/O	5VT	Default: JTDI Alternate: SPI2_NSS, I2S2_WS Remap: TIMER1_CH0, TIMER1_ETI, PA15, SPI0_NSS
PC10	139	I/O	5VT	Default: PC10 Alternate: UART3_TX, SDIO_D2, DCI_D8 Remap: USART2_TX, SPI2_SCK, I2S2_CK, TLI_R2
PC11	140	I/O	5VT	Default: PC11 Alternate: UART3_RX, SDIO_D3, DCI_D4 Remap: USART2_RX, SPI2_MISO
PC12	141	I/O	5VT	Default: PC12 Alternate: UART4_TX, SDIO_CK, DCI_D9

GD32F2071x LQFP176				
Pin Name	Pins	Pin Type ⁽¹⁾	I/O Level ⁽²⁾	Functions description
				Remap: USART2_CK, SPI2_MOSI, I2S2_SD
PD0	142	I/O	5VT	Default: PD0 Alternate: EXMC_D2 Remap: CAN0_RX, OSCIN
PD1	143	I/O	5VT	Default: PD1 Alternate: EXMC_D3 Remap: CAN0_TX, OSCOUT
PD2	144	I/O	5VT	Default: PD2 Alternate: TIMER2_ETI, UART4_RX, SDIO_CMD, DCI_D11
PD3	145	I/O	5VT	Default: PD3 Alternate: EXMC_CLK Remap: USART1_CTS, DCI_D5, TLI_G7, SPI1_SCK, I2S1_CK
PD4	146	I/O	5VT	Default: PD4 Alternate: EXMC_NOE Remap: USART1_RTS
PD5	147	I/O	5VT	Default: PD5 Alternate: EXMC_NWE Remap: USART1_TX
VSS_10	148	P		Default: VSS_10
VDD_10	149	P		Default: VDD_10
PD6	150	I/O	5VT	Default: PD6 Alternate: EXMC_NWAIT Remap: USART1_RX, DCI_D10, TLI_B2, SPI2_MOSI, I2S2_SD
PD7	151	I/O	5VT	Default: PD7 Alternate: EXMC_NE0, EXMC_NCE1 Remap: USART1_CK
PG9	152	I/O	5VT	Default: PG9 Alternate: EXMC_NE1, EXMC_NCE2 Remap: DCI_VSYNC, USART5_RX
PG10	153	I/O	5VT	Default: PG10 Alternate: EXMC_NCE3_0, EXMC_NE2 Remap: DCI_D2, TLI_G3, TLI_B2
PG11	154	I/O	5VT	Default: PG11 Alternate: EXMC_NCE3_1 Remap: DCI_D3, TLI_B3, ETH_MII_TX_EN, ETH_RMII_TX_EN
PG12	155	I/O	5VT	Default: PG12 Alternate: EXMC_NE3 Remap: USART5_RTS, TLI_B4, TLI_B1
PG13	156	I/O	5VT	Default: PG13 Alternate: EXMC_A24 Remap: USART5_CTS, ETH_MII_TXD0, ETH_RMII_TXD0
PG14	157	I/O	5VT	Default: PG14

GD32F2071x LQFP176				
Pin Name	Pins	Pin Type ⁽¹⁾	I/O Level ⁽²⁾	Functions description
				Alternate: EXMC_A25 Remap: USART5_TX, ETH_MII_TXD1, ETH_RMII_TXD1
VSS_1 1	158	P		Default: VSS_11
VDD_1 1	159	P		Default: VDD_11
PG15	160	I/O	5VT	Default: PG15 Alternate: EXMC_SDNCAS, USART5_CTS Remap: DCI_D13
PB3	161	I/O	5VT	Default: JTDO Alternate: SPI2_SCK, I2S2_CK Remap: PB3, TRACESWO, TIMER1_CH1, SPI0_SCK
PB4	162	I/O	5VT	Default: NJTRST Alternate: SPI2_MISO Remap: TIMER2_CH0, PB4, SPI0_MISO
PB5	163	I/O		Default: PB5 Alternate: I2C0_SMBA, SPI2_MOSI, I2S2_SD, ETH_PPS_OUT, DCI_D10 Remap: TIMER2_CH1, SPI0_MOSI, CAN1_RX, EXMC_SDCKE1
PB6	164	I/O	5VT	Default: PB6 Alternate: I2C0_SCL, TIMER3_CH0, DCI_D5 Remap: USART0_TX, CAN1_TX, EXMC_SDNE1, SPI0_IO3
PB7	165	I/O	5VT	Default: PB7 Alternate: I2C0_SDA, TIMER3_CH1, EXMC_NL/EXMC_NADV, DCI_VSYNC Remap: USART0_RX, SPI0_IO4
BOOT0	166	I		Default: BOOT0
PB8	167	I/O	5VT	Default: PB8 Alternate: TIMER3_CH2, TIMER9_CH0, ETH_MII_TXD3, SDIO_D4, DCI_D6 Remap: I2C0_SCL, CAN0_RX, TLI_B6
PB9	168	I/O	5VT	Default: PB9 Alternate: TIMER3_CH3, TIMER10_CH0, SDIO_D5, DCI_D7 Remap: I2C0_SDA, CAN0_TX, TLI_B7, SPI1_NSS, I2S1_WS
PE0	169	I/O	5VT	Default: PE0 Alternate: TIMER3_ETI, EXMC_NBL0, UART7_RX Remap: DCI_D2
PE1	170	I/O	5VT	Default: PE1 Alternate: EXMC_NBL1, UART7_TX Remap: DCI_D3
VSS_3	171	P		Default: VSS_3
VDD_3	172	P		Default: VDD_3
PI4	173	I/O	5VT	Default: PI4

GD32F2071x LQFP176				
Pin Name	Pins	Pin Type ⁽¹⁾	I/O Level ⁽²⁾	Functions description
				Alternate: EXMC_NBL2 Remap: TLI_B4, TIMER7_BRKIN, DCI_D5
PI5	174	I/O	5VT	Default: PI5 Alternate: EXMC_NBL3 Remap: TLI_B5, TIMER7_CH0, DCI_VSYNC
PI6	175	I/O	5VT	Default: PI6 Alternate: EXMC_D28 Remap: TLI_B6, TIMER7_CH1, DCI_D6
PI7	176	I/O	5VT	Default: PI7 Alternate: EXMC_D29 Remap: TLI_B7, TIMER7_CH2, DCI_D7

Notes:

- (1) Type: I = input, O = output, P = power.
- (2) I/O Level: 5VT = 5 V tolerant.

2.6.2. GD32F207Zx LQFP144 pin definitions

Table 2-4. GD32F207Zx LQFP144 pin definitions

GD32F207Zx LQFP144				
Pin Name	Pins	Pin Type ⁽¹⁾	I/O Level ⁽²⁾	Functions description
PE2	1	I/O	5VT	Default: PE2 Alternate: TRACECK, EXMC_A23 Remap: ETH_MII_TXD3
PE3	2	I/O	5VT	Default: PE3 Alternate: TRACED0, EXMC_A19
PE4	3	I/O	5VT	Default: PE4 Alternate: TRACED1, EXMC_A20 Remap: DCI_D4, TLI_B0
PE5	4	I/O	5VT	Default: PE5 Alternate: TRACED2, EXMC_A21 Remap: TIMER8_CH0, DCI_D6, TLI_G0
PE6	5	I/O	5VT	Default: PE6 Alternate: TRACED3, EXMC_A22 Remap: TIMER8_CH1, DCI_D7, TLI_G1
VBAT	6	P		Default: VBAT
PC13-TAMPER-RTC	7	I/O	5VT	Default: PC13 Alternate: TAMPER-RTC
PC14-OSC32IN	8	I/O		Default: PC14 Alternate: OSC32IN
PC15-OSC32OUT	9	I/O		Default: PC15 Alternate: OSC32OUT
PF0	10	I/O	5VT	Default: PF0 Alternate: EXMC_A0 Remap: I2C1_SDA
PF1	11	I/O	5VT	Default: PF1 Alternate: EXMC_A1 Remap: I2C1_SCL
PF2	12	I/O	5VT	Default: PF2 Alternate: EXMC_A2 Remap: I2C1_SMBA
PF3	13	I/O	5VT	Default: PF3 Alternate: EXMC_A3, ADC2_IN9
PF4	14	I/O	5VT	Default: PF4 Alternate: EXMC_A4, ADC2_IN14
PF5	15	I/O	5VT	Default: PF5 Alternate: EXMC_A5, ADC2_IN15
VSS_5	16	P		Default: VSS_5
VDD_5	17	P		Default: VDD_5
PF6	18	I/O		Default: PF6

GD32F207Zx LQFP144				
Pin Name	Pins	Pin Type ⁽¹⁾	I/O Level ⁽²⁾	Functions description
				Alternate: ADC2_IN4, EXMC_NIORD Remap: TIMER9_CH0, UART6_RX
PF7	19	I/O		Default: PF7 Alternate: ADC2_IN5, EXMC_NREG Remap: TIMER10_CH0, UART6_TX
PF8	20	I/O		Default: PF8 Alternate: ADC2_IN6, EXMC_NIOWR Remap: TIMER12_CH0
PF9	21	I/O		Default: PF9 Alternate: ADC2_IN7, EXMC_CD Remap: TIMER13_CH0
PF10	22	I/O		Default: PF10 Alternate: ADC2_IN8, EXMC_INTR Remap: DCI_D11, TLI_DE
OSCIN	23	I		Default: OSCIN Remap: PD0, PH0
OSCOU	24	O		Default: OSCOUT Remap: PD1, PH1
NRST	25	I/O		Default: NRST
PC0	26	I/O		Default: PC0 Alternate: ADC012_IN10 Remap: EXMC_SDNWE
PC1	27	I/O		Default: PC1 Alternate: ADC012_IN11, ETH_MDC
PC2	28	I/O		Default: PC2 Alternate: ADC012_IN12, ETH_MII_TXD2 Remap: EXMC_SDNE0, SPI1_MISO
PC3	29	I/O		Default: PC3 Alternate: ADC012_IN13, ETH_MII_TX_CLK Remap: EXMC_SDCKE0, SPI1_MOSI, I2S1_SD
VSSA	30	P		Default: VSSA
VREFN	31	P		Default: VREFN
VREFP	32	P		Default: VREFP
VDDA	33	P		Default: VDDA
PA0-WKUP	34	I/O		Default: PA0 Alternate: WKUP, USART1_CTS, ADC012_IN0, TIMER1_CH0, TIMER1_ETI, TIMER4_CH0, TIMER7_ETI, ETH_MII_CRS Remap: UART3_TX
PA1	35	I/O		Default: PA1 Alternate: USART1_RTS, ADC012_IN1, TIMER1_CH1, TIMER4_CH1, ETH_MII_RX_CLK, ETH_RMII_REF_CLK Remap: UART3_RX

GD32F207Zx LQFP144				
Pin Name	Pins	Pin Type ⁽¹⁾	I/O Level ⁽²⁾	Functions description
PA2	36	I/O		Default: PA2 Alternate: USART1_TX, ADC012_IN2, TIMER1_CH2, TIMER4_CH2, TIMER8_CH0, ETH_MDIO, SPI0_IO3
PA3	37	I/O		Default: PA3 Alternate: USART1_RX, ADC012_IN3, TIMER1_CH3, TIMER4_CH3, TIMER8_CH1, ETH_MII_COL, SPI0_IO4 Remap: TLI_B5
VSS_4	38	P		Default: VSS_4
VDD_4	39	P		Default: VDD_4
PA4	40	I/O		Default: PA4 Alternate: SPI0_NSS, USART1_CK, DAC_OUT0, ADC01_IN4, DCI_HSYNC Remap: SPI2_NSS, I2S2_WS, TLI_VSYNC
PA5	41	I/O		Default: PA5 Alternate: SPI0_SCK, ADC01_IN5, DAC_OUT1 Remap: TIMER1_CH0, TIMER1_ETI, TIMER7_CH0_ON
PA6	42	I/O		Default: PA6 Alternate: SPI0_MISO, ADC01_IN6, TIMER2_CH0, TIMER7_BRKIN, TIMER12_CH0, DCI_PIXCLK Remap: TIMER0_BRKIN, TLI_G2
PA7	43	I/O		Default: PA7 Alternate: SPI0_MOSI, ADC01_IN7, TIMER2_CH1, TIMER7_CH0_ON, TIMER13_CH0, ETH_MII_RX_DV, ETH_RMII_CRS_DV Remap: TIMER0_CH0_ON
PC4	44	I/O		Default: PC4 Alternate: ADC01_IN14, ETH_MII_RXD0, ETH_RMII_RXD0
PC5	45	I/O		Default: PC5 Alternate: ADC01_IN15, ETH_MII_RXD1, ETH_RMII_RXD1
PB0	46	I/O		Default: PB0 Alternate: ADC01_IN8, TIMER2_CH2, TIMER7_CH1_ON, ETH_MII_RXD2 Remap: TIMER0_CH1_ON, TLI_R3
PB1	47	I/O		Default: PB1 Alternate: ADC01_IN9, TIMER2_CH3, TIMER7_CH2_ON, ETH_MII_RXD3 Remap: TIMER0_CH2_ON, TLI_R6
PB2	48	I/O	5VT	Default: PB2, BOOT1
PF11	49	I/O	5VT	Default: PF11 Alternate: EXMC_NIOS16, DCI_D12, EXMC_SDNRAS
PF12	50	I/O	5VT	Default: PF12 Alternate: EXMC_A6
VSS_6	51	P		Default: VSS_6
VDD_6	52	P		Default: VDD_6

GD32F207Zx LQFP144				
Pin Name	Pins	Pin Type ⁽¹⁾	I/O Level ⁽²⁾	Functions description
PF13	53	I/O	5VT	Default: PF13 Alternate: EXMC_A7
PF14	54	I/O	5VT	Default: PF14 Alternate: EXMC_A8
PF15	55	I/O	5VT	Default: PF15 Alternate: EXMC_A9
PG0	56	I/O	5VT	Default: PG0 Alternate: EXMC_A10
PG1	57	I/O	5VT	Default: PG1 Alternate: EXMC_A11
PE7	58	I/O	5VT	Default: PE7 Alternate: EXMC_D4, UART6_RX Remap: TIMER0_ETI
PE8	59	I/O	5VT	Default: PE8 Alternate: EXMC_D5, UART6_TX Remap: TIMER0_CH0_ON
PE9	60	I/O	5VT	Default: PE9 Alternate: EXMC_D6 Remap: TIMER0_CH0
VSS_7	61	P		Default: VSS_7
VDD_7	62	P		Default: VDD_7
PE10	63	I/O	5VT	Default: PE10 Alternate: EXMC_D7 Remap: TIMER0_CH1_ON
PE11	64	I/O	5VT	Default: PE11 Alternate: EXMC_D8 Remap: TIMER0_CH1, TLI_G3
PE12	65	I/O	5VT	Default: PE12 Alternate: EXMC_D9 Remap: TIMER0_CH2_ON, TLI_B4
PE13	66	I/O	5VT	Default: PE13 Alternate: EXMC_D10 Remap: TIMER0_CH2, TLI_DE
PE14	67	I/O	5VT	Default: PE14 Alternate: EXMC_D11 Remap: TIMER0_CH3, TLI_PIXCLK
PE15	68	I/O	5VT	Default: PE15 Alternate: EXMC_D12 Remap: TIMER0_BRKIN, TLI_R7
PB10	69	I/O	5VT	Default: PB10 Alternate: I2C1_SCL, USART2_TX, ETH_MII_RX_ER Remap: TIMER1_CH2, TLI_G4, SPI1_SCK, I2S1_CK
PB11	70	I/O	5VT	Default: PB11 Alternate: I2C1_SDA, USART2_RX, ETH_MII_TX_EN,

GD32F207Zx LQFP144				
Pin Name	Pins	Pin Type ⁽¹⁾	I/O Level ⁽²⁾	Functions description
				ETH_RMII_TX_EN Remap: TIMER1_CH3, TLI_G5
VSS_1	71	P		Default: VSS_1
VDD_1	72	P		Default: VDD_1
PB12	73	I/O	5VT	Default: PB12 Alternate: SPI1_NSS, I2C1_SMBA, USART2_CK, TIMER0_BRKIN, I2S1_WS, CAN1_RX, ETH_MII_TXD0, ETH_RMII_TXD0
PB13	74	I/O	5VT	Default: PB13 Alternate: SPI1_SCK, USART2_CTS, TIMER0_CH0_ON, I2S1_CK, CAN1_TX, ETH_MII_TXD1, ETH_RMII_TXD1
PB14	75	I/O	5VT	Default: PB14 Alternate: SPI1_MISO, USART2_RTS, TIMER0_CH1_ON, TIMER11_CH0
PB15	76	I/O	5VT	Default: PB15 Alternate: SPI1_MOSI, TIMER0_CH2_ON, I2S1_SD, TIMER11_CH1
PD8	77	I/O	5VT	Default: PD8 Alternate: EXMC_D13 Remap: USART2_TX, ETH_MII_RX_DV, ETH_RMII_CRD_DV
PD9	78	I/O	5VT	Default: PD9 Alternate: EXMC_D14 Remap: USART2_RX, ETH_MII_RXD0, ETH_RMII_RXD0
PD10	79	I/O	5VT	Default: PD10 Alternate: EXMC_D15 Remap: USART2_CK, ETH_MII_RXD1, ETH_RMII_RXD1, TLI_B3
PD11	80	I/O	5VT	Default: PD11 Alternate: EXMC_A16/EXMC_CLE Remap: USART2_CTS, ETH_MII_RXD2
PD12	81	I/O	5VT	Default: PD12 Alternate: EXMC_A17/EXMC_ALE Remap: TIMER3_CH0, USART2_RTS
PD13	82	I/O	5VT	Default: PD13 Alternate: EXMC_A18 Remap: TIMER3_CH1
VSS_8	83	P		Default: VSS_8
VDD_8	84	P		Default: VDD_8
PD14	85	I/O	5VT	Default: PD14 Alternate: EXMC_D0 Remap: TIMER3_CH2
PD15	86	I/O	5VT	Default: PD15 Alternate: EXMC_D1

GD32F207Zx LQFP144				
Pin Name	Pins	Pin Type ⁽¹⁾	I/O Level ⁽²⁾	Functions description
				Remap: TIMER3_CH3
PG2	87	I/O	5VT	Default: PG2 Alternate: EXMC_A12
PG3	88	I/O	5VT	Default: PG3 Alternate: EXMC_A13
PG4	89	I/O	5VT	Default: PG4 Alternate: EXMC_A14, EXMC_BA0
PG5	90	I/O	5VT	Default: PG5 Alternate: EXMC_A15, EXMC_BA1
PG6	91	I/O	5VT	Default: PG6 Alternate: EXMC_INT1 Remap: DCI_D12, TLI_R7
PG7	92	I/O	5VT	Default: PG7 Alternate: EXMC_INT2, DCI_D13 Remap: USART5_CK, TLI_PIXCLK
PG8	93	I/O	5VT	Default: PG8 Alternate: EXMC_SDCLK, USART5_RTS Remap: ETH_PPS_OUT
VSS_9	94	P		Default: VSS_9
VDD_9	95	P		Default: VDD_9
PC6	96	I/O	5VT	Default: PC6 Alternate: I2S1_MCK, TIMER7_CH0, SDIO_D6, USART5_TX Remap: TIMER2_CH0, DCI_D0, TLI_HSYNC
PC7	97	I/O	5VT	Default: PC7 Alternate: I2S2_MCK, TIMER7_CH1, SDIO_D7, USART5_RX Remap: TIMER2_CH1, DCI_D1, TLI_G6
PC8	98	I/O	5VT	Default: PC8 Alternate: TIMER7_CH2, SDIO_D0, DCI_D2, USART5_CK Remap: TIMER2_CH2
PC9	99	I/O	5VT	Default: PC9 Alternate: TIMER7_CH3, SDIO_D1, DCI_D3, CK_OUT1 Remap: TIMER2_CH3, I2C2_SDA
PA8	100	I/O	5VT	Default: PA8 Alternate: USART0_CK, TIMER0_CH0, CK_OUT0, VCORE, USBFS_SOF Remap: TLI_R6, I2C2_SCL
PA9	101	I/O	5VT	Default: PA9 Alternate: USART0_TX, TIMER0_CH1, USBFS_VBUS, DCI_D0 Remap: I2C2_SMBAL
PA10	102	I/O	5VT	Default: PA10 Alternate: USART0_RX, TIMER0_CH2, USBFS_ID, DCI_D1

GD32F207Zx LQFP144				
Pin Name	Pins	Pin Type ⁽¹⁾	I/O Level ⁽²⁾	Functions description
PA11	103	I/O	5VT	Default: PA11 Alternate: USART0_CTS, CAN0_RX, USBFS_DM, TIMER0_CH3 Remap: TLI_R4
PA12	104	I/O	5VT	Default: PA12 Alternate: USART0_RTS, USBFS_DP, CAN0_TX, TIMER0_ETI Remap: TLI_R5
PA13	105	I/O	5VT	Default: JTMS, SWDIO Remap: PA13
NC	106			-
VSS_2	107	P		Default: VSS_2
VDD_2	108	P		Default: VDD_2
PA14	109	I/O	5VT	Default: JTCK, SWCLK Remap: PA14
PA15	110	I/O	5VT	Default: JTDI Alternate: SPI2_NSS, I2S2_WS Remap: TIMER1_CH0, TIMER1_ETI, PA15, SPI0_NSS
PC10	111	I/O	5VT	Default: PC10 Alternate: UART3_TX, SDIO_D2, DCI_D8 Remap: USART2_TX, SPI2_SCK, I2S2_CK, TLI_R2
PC11	112	I/O	5VT	Default: PC11 Alternate: UART3_RX, SDIO_D3, DCI_D4 Remap: USART2_RX, SPI2_MISO
PC12	113	I/O	5VT	Default: PC12 Alternate: UART4_TX, SDIO_CK, DCI_D9 Remap: USART2_CK, SPI2_MOSI, I2S2_SD
PD0	114	I/O	5VT	Default: PD0 Alternate: EXMC_D2 Remap: CAN0_RX, OSCIN
PD1	115	I/O	5VT	Default: PD1 Alternate: EXMC_D3 Remap: CAN0_TX, OSCOUT
PD2	116	I/O	5VT	Default: PD2 Alternate: TIMER2_ETI, UART4_RX, SDIO_CMD, DCI_D11
PD3	117	I/O	5VT	Default: PD3 Alternate: EXMC_CLK Remap: USART1_CTS, DCI_D5, TLI_G7, SPI1_SCK, I2S1_CK
PD4	118	I/O	5VT	Default: PD4 Alternate: EXMC_NOE Remap: USART1_RTS
PD5	119	I/O	5VT	Default: PD5 Alternate: EXMC_NWE

GD32F207Zx LQFP144				
Pin Name	Pins	Pin Type ⁽¹⁾	I/O Level ⁽²⁾	Functions description
				Remap: USART1_TX
VSS_10	120	P		Default: VSS_10
VDD_10	121	P		Default: VDD_10
PD6	122	I/O	5VT	Default: PD6 Alternate: EXMC_NWAIT Remap: USART1_RX, DCI_D10, TLI_B2, SPI2_MOSI, I2S2_SD
PD7	123	I/O	5VT	Default: PD7 Alternate: EXMC_NE0, EXMC_NCE1 Remap: USART1_CK
PG9	124	I/O	5VT	Default: PG9 Alternate: EXMC_NE1, EXMC_NCE2 Remap: DCI_VSYNC, USART5_RX
PG10	125	I/O	5VT	Default: PG10 Alternate: EXMC_NCE3_0, EXMC_NE2 Remap: DCI_D2, TLI_G3, TLI_B2
PG11	126	I/O	5VT	Default: PG11 Alternate: EXMC_NCE3_1 Remap: DCI_D3, TLI_B3, ETH_MII_TX_EN, ETH_RMII_TX_EN
PG12	127	I/O	5VT	Default: PG12 Alternate: EXMC_NE3 Remap: USART5_RTS, TLI_B4, TLI_B1
PG13	128	I/O	5VT	Default: PG13 Alternate: EXMC_A24 Remap: USART5_CTS, ETH_MII_TXD0, ETH_RMII_TXD0
PG14	129	I/O	5VT	Default: PG14 Alternate: EXMC_A25 Remap: USART5_TX, ETH_MII_TXD1, ETH_RMII_TXD1
VSS_11	130	P		Default: VSS_11
VDD_11	131	P		Default: VDD_11
PG15	132	I/O	5VT	Default: PG15 Alternate: EXMC_SDNCAS, USART5_CTS Remap: DCI_D13
PB3	133	I/O	5VT	Default: JTDO Alternate: SPI2_SCK, I2S2_CK Remap: PB3, TRACESWO, TIMER1_CH1, SPI0_SCK
PB4	134	I/O	5VT	Default: JNTRST Alternate: SPI2_MISO Remap: TIMER2_CH0, PB4, SPI0_MISO
PB5	135	I/O		Default: PB5 Alternate: I2C0_SMBA, SPI2_MOSI, I2S2_SD, ETH_PPS_OUT, DCI_D10 Remap: TIMER2_CH1, SPI0_MOSI, CAN1_RX,

GD32F207Zx LQFP144				
Pin Name	Pins	Pin Type ⁽¹⁾	I/O Level ⁽²⁾	Functions description
				EXMC_SDCKE1
PB6	136	I/O	5VT	Default: PB6 Alternate: I2C0_SCL, TIMER3_CH0, DCI_D5 Remap: USART0_TX, CAN1_TX, EXMC_SDNE1, SPI0_IO3
PB7	137	I/O	5VT	Default: PB7 Alternate: I2C0_SDA, TIMER3_CH1, EXMC_NL/EXMC_NADV, DCI_VSYNC Remap: USART0_RX, SPI0_IO4
BOOT0	138	I		Default: BOOT0
PB8	139	I/O	5VT	Default: PB8 Alternate: TIMER3_CH2, TIMER9_CH0, ETH_MII_TXD3, SDIO_D4, DCI_D6 Remap: I2C0_SCL, CAN0_RX, TLI_B6
PB9	140	I/O	5VT	Default: PB9 Alternate: TIMER3_CH3, TIMER10_CH0, SDIO_D5, DCI_D7 Remap: I2C0_SDA, CAN0_TX, TLI_B7, SPI1_NSS, I2S1_WS
PE0	141	I/O	5VT	Default: PE0 Alternate: TIMER3_ETI, EXMC_NBL0, UART7_RX Remap: DCI_D2
PE1	142	I/O	5VT	Default: PE1 Alternate: EXMC_NBL1, UART7_TX Remap: DCI_D3
VSS_3	143	P		Default: VSS_3
VDD_3	144	P		Default: VDD_3

Notes:

- (1) Type: I = input, O = output, P = power.
(2) I/O Level: 5VT = 5 V tolerant.

2.6.3. GD32F207Vx LQFP100 pin definitions

Table 2-5. GD32F207Vx LQFP100 pin definitions

GD32F207Vx LQFP100				
Pin Name	Pins	Pin Type ⁽¹⁾	I/O Level ⁽²⁾	Functions description
PE2	1	I/O	5VT	Default: PE2 Alternate: TRACECK, EXMC_A23 Remap: ETH_MII_TXD3
PE3	2	I/O	5VT	Default: PE3 Alternate: TRACED0, EXMC_A19
PE4	3	I/O	5VT	Default: PE4 Alternate: TRACED1, EXMC_A20 Remap: DCI_D4, TLI_B0
PE5	4	I/O	5VT	Default: PE5 Alternate: TRACED2, EXMC_A21 Remap: TIMER8_CH0, DCI_D6, TLI_G0
PE6	5	I/O	5VT	Default: PE6 Alternate: TRACED3, EXMC_A22 Remap: TIMER8_CH1, DCI_D7, TLI_G1
VBAT	6	P		Default: VBAT
PC13-TAMPER-RTC	7	I/O	5VT	Default: PC13 Alternate: TAMPER-RTC
PC14-OSC32IN	8	I/O		Default: PC14 Alternate: OSC32IN
PC15-OSC32OUT	9	I/O		Default: PC15 Alternate: OSC32OUT
VSS_5	10	P		Default: VSS_5
VDD_5	11	P		Default: VDD_5
OSCIN	12	I		Default: OSCIN Remap: PD0, PH0
OSCOUT	13	O		Default: OSCOUT Remap: PD1, PH1
NRST	14	I/O		Default: NRST
PC0	15	I/O		Default: PC0 Alternate: ADC012_IN10 Remap: EXMC_SDNWE
PC1	16	I/O		Default: PC1 Alternate: ADC012_IN11, ETH_MDC
PC2	17	I/O		Default: PC2 Alternate: ADC012_IN12, ETH_MII_TXD2 Remap: EXMC_SDNE0, SPI1_MISO
PC3	18	I/O		Default: PC3 Alternate: ADC012_IN13, ETH_MII_TX_CLK Remap: EXMC_SDCKE0, SPI1_MOSI, I2S1_SD

GD32F207Vx LQFP100				
Pin Name	Pins	Pin Type ⁽¹⁾	I/O Level ⁽²⁾	Functions description
VSSA	19	P		Default: VSSA
VREFN	20	P		Default: VREFN
VREFP	21	P		Default: VREFP
VDDA	22	P		Default: VDDA
PA0-WKUP	23	I/O		Default: PA0 Alternate: WKUP, USART1_CTS, ADC012_IN0, TIMER1_CH0, TIMER1_ETI, TIMER4_CH0, TIMER7_ETI, ETH_MII_CRS Remap: UART3_TX
PA1	24	I/O		Default: PA1 Alternate: USART1_RTS, ADC012_IN1, TIMER1_CH1, TIMER4_CH1, ETH_MII_RX_CLK, ETH_RMII_REF_CLK Remap: UART3_RX
PA2	25	I/O		Default: PA2 Alternate: USART1_TX, ADC012_IN2, TIMER1_CH2, TIMER4_CH2, TIMER8_CH0, ETH_MDIO, SPI0_IO3
PA3	26	I/O		Default: PA3 Alternate: USART1_RX, ADC012_IN3, TIMER1_CH3, TIMER4_CH3, TIMER8_CH1, ETH_MII_COL, SPI0_IO4 Remap: TLI_B5
VSS_4	27	P		Default: VSS_4
VDD_4	28	P		Default: VDD_4
PA4	29	I/O		Default: PA4 Alternate: SPI0_NSS, USART1_CK, DAC_OUT0, ADC01_IN4, DCI_HSYNC Remap: SPI2_NSS, I2S2_WS, TLI_VSYNC
PA5	30	I/O		Default: PA5 Alternate: SPI0_SCK, ADC01_IN5, DAC_OUT1 Remap: TIMER1_CH0, TIMER1_ETI, TIMER7_CH0_ON
PA6	31	I/O		Default: PA6 Alternate: SPI0_MISO, ADC01_IN6, TIMER2_CH0, TIMER7_BRKIN, TIMER12_CH0, DCI_PIXCLK Remap: TIMER0_BRKIN, TLI_G2
PA7	32	I/O		Default: PA7 Alternate: SPI0_MOSI, ADC01_IN7, TIMER2_CH1, TIMER7_CH0_ON, TIMER13_CH0, ETH_MII_RX_DV, ETH_RMII_CRS_DV Remap: TIMER0_CH0_ON
PC4	33	I/O		Default: PC4 Alternate: ADC01_IN14, ETH_MII_RXD0, ETH_RMII_RXD0
PC5	34	I/O		Default: PC5 Alternate: ADC01_IN15, ETH_MII_RXD1, ETH_RMII_RXD1
PB0	35	I/O		Default: PB0 Alternate: ADC01_IN8, TIMER2_CH2, TIMER7_CH1_ON,

GD32F207Vx LQFP100				
Pin Name	Pins	Pin Type ⁽¹⁾	I/O Level ⁽²⁾	Functions description
				ETH_MII_RXD2 Remap: TIMER0_CH1_ON, TLI_R3
PB1	36	I/O		Default: PB1 Alternate: ADC01_IN9, TIMER2_CH3, TIMER7_CH2_ON, ETH_MII_RXD3 Remap: TIMER0_CH2_ON, TLI_R6
PB2	37	I/O	5VT	Default: PB2, BOOT1
PE7	38	I/O	5VT	Default: PE7 Alternate: EXMC_D4, UART6_RX Remap: TIMER0_ETI
PE8	39	I/O	5VT	Default: PE8 Alternate: EXMC_D5, UART6_TX Remap: TIMER0_CH0_ON
PE9	40	I/O	5VT	Default: PE9 Alternate: EXMC_D6 Remap: TIMER0_CH0
PE10	41	I/O	5VT	Default: PE10 Alternate: EXMC_D7 Remap: TIMER0_CH1_ON
PE11	42	I/O	5VT	Default: PE11 Alternate: EXMC_D8 Remap: TIMER0_CH1, TLI_G3
PE12	43	I/O	5VT	Default: PE12 Alternate: EXMC_D9 Remap: TIMER0_CH2_ON, TLI_B4
PE13	44	I/O	5VT	Default: PE13 Alternate: EXMC_D10 Remap: TIMER0_CH2, TLI_DE
PE14	45	I/O	5VT	Default: PE14 Alternate: EXMC_D11 Remap: TIMER0_CH3, TLI_PIXCLK
PE15	46	I/O	5VT	Default: PE15 Alternate: EXMC_D12 Remap: TIMER0_BRKIN, TLI_R7
PB10	47	I/O	5VT	Default: PB10 Alternate: I2C1_SCL, USART2_TX, ETH_MII_RX_ER Remap: TIMER1_CH2, TLI_G4, SPI1_SCK, I2S1_CK
PB11	48	I/O	5VT	Default: PB11 Alternate: I2C1_SDA, USART2_RX, ETH_MII_TX_EN, ETH_RMII_TX_EN Remap: TIMER1_CH3, TLI_G5
VSS_1	49	P		Default: VSS_1
VDD_1	50	P		Default: VDD_1
PB12	51	I/O	5VT	Default: PB12

GD32F207Vx LQFP100				
Pin Name	Pins	Pin Type ⁽¹⁾	I/O Level ⁽²⁾	Functions description
				Alternate: SPI1_NSS, I2C1_SMBA, USART2_CK, TIMER0_BRKIN, I2S1_WS, CAN1_RX, ETH_MII_TXD0, ETH_RMII_TXD0
PB13	52	I/O	5VT	Default: PB13 Alternate: SPI1_SCK, USART2_CTS, TIMER0_CH0_ON, I2S1_CK, CAN1_TX, ETH_MII_TXD1, ETH_RMII_TXD1
PB14	53	I/O	5VT	Default: PB14 Alternate: SPI1_MISO, USART2_RTS, TIMER0_CH1_ON, TIMER11_CH0
PB15	54	I/O	5VT	Default: PB15 Alternate: SPI1_MOSI, TIMER0_CH2_ON, I2S1_SD, TIMER11_CH1
PD8	55	I/O	5VT	Default: PD8 Alternate: EXMC_D13 Remap: USART2_TX, ETH_MII_RX_DV, ETH_RMII_CRD_DV
PD9	56	I/O	5VT	Default: PD9 Alternate: EXMC_D14 Remap: USART2_RX, ETH_MII_RXD0, ETH_RMII_RXD0
PD10	57	I/O	5VT	Default: PD10 Alternate: EXMC_D15 Remap: USART2_CK, ETH_MII_RXD1, ETH_RMII_RXD1, TLI_B3
PD11	58	I/O	5VT	Default: PD11 Alternate: EXMC_A16/EXMC_CLE Remap: USART2_CTS, ETH_MII_RXD2
PD12	59	I/O	5VT	Default: PD12 Alternate: EXMC_A17/EXMC_ALE Remap: TIMER3_CH0, USART2_RTS
PD13	60	I/O	5VT	Default: PD13 Alternate: EXMC_A18 Remap: TIMER3_CH1
PD14	61	I/O	5VT	Default: PD14 Alternate: EXMC_D0 Remap: TIMER3_CH2
PD15	62	I/O	5VT	Default: PD15 Alternate: EXMC_D1 Remap: TIMER3_CH3
PC6	63	I/O	5VT	Default: PC6 Alternate: I2S1_MCK, TIMER7_CH0, SDIO_D6, USART5_TX Remap: TIMER2_CH0, DCI_D0, TLI_HSYNC
PC7	64	I/O	5VT	Default: PC7 Alternate: I2S2_MCK, TIMER7_CH1, SDIO_D7, USART5_RX

GD32F207Vx LQFP100				
Pin Name	Pins	Pin Type ⁽¹⁾	I/O Level ⁽²⁾	Functions description
				Remap: TIMER2_CH1, DCI_D1, TLI_G6
PC8	65	I/O	5VT	Default: PC8 Alternate: TIMER7_CH2, SDIO_D0, DCI_D2, USART5_CK Remap: TIMER2_CH2
PC9	66	I/O	5VT	Default: PC9 Alternate: TIMER7_CH3, SDIO_D1, DCI_D3, CK_OUT1 Remap: TIMER2_CH3, I2C2_SDA
PA8	67	I/O	5VT	Default: PA8 Alternate: USART0_CK, TIMER0_CH0, CK_OUT0, VCORE, USBFS_SOF Remap: TLI_R6, I2C2_SCL
PA9	68	I/O	5VT	Default: PA9 Alternate: USART0_TX, TIMER0_CH1, USBFS_VBUS, DCI_D0 Remap: I2C2_SMBA1
PA10	69	I/O	5VT	Default: PA10 Alternate: USART0_RX, TIMER0_CH2, USBFS_ID, DCI_D1
PA11	70	I/O	5VT	Default: PA11 Alternate: USART0_CTS, CAN0_RX, USBFS_DM, TIMER0_CH3 Remap: TLI_R4
PA12	71	I/O	5VT	Default: PA12 Alternate: USART0_RTS, USBFS_DP, CAN0_TX, TIMER0_ETI Remap: TLI_R5
PA13	72	I/O	5VT	Default: JTMS, SWDIO Remap: PA13
NC	73			-
VSS_2	74	P		Default: VSS_2
VDD_2	75	P		Default: VDD_2
PA14	76	I/O	5VT	Default: JTCK, SWCLK Remap: PA14
PA15	77	I/O	5VT	Default: JTDI Alternate: SPI2_NSS, I2S2_WS Remap: TIMER1_CH0, TIMER1_ETI, PA15, SPI0_NSS
PC10	78	I/O	5VT	Default: PC10 Alternate: UART3_TX, SDIO_D2, DCI_D8 Remap: USART2_TX, SPI2_SCK, I2S2_CK, TLI_R2
PC11	79	I/O	5VT	Default: PC11 Alternate: UART3_RX, SDIO_D3, DCI_D4 Remap: USART2_RX, SPI2_MISO
PC12	80	I/O	5VT	Default: PC12 Alternate: UART4_TX, SDIO_CK, DCI_D9 Remap: USART2_CK, SPI2_MOSI, I2S2_SD

GD32F207Vx LQFP100				
Pin Name	Pins	Pin Type ⁽¹⁾	I/O Level ⁽²⁾	Functions description
PD0	81	I/O	5VT	Default: PD0 Alternate: EXMC_D2 Remap: CAN0_RX, OSCIN
PD1	82	I/O	5VT	Default: PD1 Alternate: EXMC_D3 Remap: CAN0_TX, OSCOUT
PD2	83	I/O	5VT	Default: PD2 Alternate: TIMER2_ETI, UART4_RX, SDIO_CMD, DCI_D11
PD3	84	I/O	5VT	Default: PD3 Alternate: EXMC_CLK Remap: USART1_CTS, DCI_D5, TLI_G7, SPI1_SCK, I2S1_CK
PD4	85	I/O	5VT	Default: PD4 Alternate: EXMC_NOE Remap: USART1_RTS
PD5	86	I/O	5VT	Default: PD5 Alternate: EXMC_NWE Remap: USART1_TX
PD6	87	I/O	5VT	Default: PD6 Alternate: EXMC_NWAIT Remap: USART1_RX, DCI_D10, TLI_B2, SPI2_MOSI, I2S2_SD
PD7	88	I/O	5VT	Default: PD7 Alternate: EXMC_NE0, EXMC_NCE1 Remap: USART1_CK
PB3	89	I/O	5VT	Default: JTDO Alternate: SPI2_SCK, I2S2_CK Remap: PB3, TRACESWO, TIMER1_CH1, SPI0_SCK
PB4	90	I/O	5VT	Default: JNTRST Alternate: SPI2_MISO Remap: TIMER2_CH0, PB4, SPI0_MISO
PB5	91	I/O		Default: PB5 Alternate: I2C0_SMBA, SPI2_MOSI, I2S2_SD, ETH_PPS_OUT, DCI_D10 Remap: TIMER2_CH1, SPI0_MOSI, CAN1_RX, EXMC_SDCKE1
PB6	92	I/O	5VT	Default: PB6 Alternate: I2C0_SCL, TIMER3_CH0, DCI_D5 Remap: USART0_TX, CAN1_TX, EXMC_SDNE1, SPI0_IO3
PB7	93	I/O	5VT	Default: PB7 Alternate: I2C0_SDA, TIMER3_CH1, EXMC_NL/EXMC_NADV, DCI_VSYNC Remap: USART0_RX, SPI0_IO4
BOOT0	94	I		Default: BOOT0

GD32F207Vx LQFP100				
Pin Name	Pins	Pin Type ⁽¹⁾	I/O Level ⁽²⁾	Functions description
PB8	95	I/O	5VT	Default: PB8 Alternate: TIMER3_CH2, TIMER9_CH0, ETH_MII_TXD3, SDIO_D4, DCI_D6 Remap: I2C0_SCL, CAN0_RX, TLI_B6
PB9	96	I/O	5VT	Default: PB9 Alternate: TIMER3_CH3, TIMER10_CH0, SDIO_D5, DCI_D7 Remap: I2C0_SDA, CAN0_TX, TLI_B7, SPI1_NSS, I2S1_WS
PE0	97	I/O	5VT	Default: PE0 Alternate: TIMER3_ETI, EXMC_NBL0, UART7_RX Remap: DCI_D2
PE1	98	I/O	5VT	Default: PE1 Alternate: EXMC_NBL1, UART7_TX Remap: DCI_D3
VSS_3	99	P		Default: VSS_3
VDD_3	100	P		Default: VDD_3

Notes:

- (1) Type: I = input, O = output, P = power.
(2) I/O Level: 5VT = 5 V tolerant.

2.6.4. GD32F207Rx LQFP64 pin definitions

Table 2-6. GD32F207Rx LQFP64 pin definitions

GD32F207Rx LQFP64				
Pin Name	Pins	Pin Type ⁽¹⁾	I/O Level ⁽²⁾	Functions description
VBAT	1	P		Default: VBAT
PC13-TAMPER-RTC	2	I/O	5VT	Default: PC13 Alternate: TAMPER-RTC
PC14-OSC32IN	3	I/O		Default: PC14 Alternate: OSC32IN
PC15-OSC32OUT	4	I/O		Default: PC15 Alternate: OSC32OUT
OSCIN	5	I		Default: OSCIN Remap: PD0
OSCOUT	6	O		Default: OSCOUT Remap: PD1
NRST	7	I/O		Default: NRST
PC0	8	I/O		Default: PC0 Alternate: ADC012_IN10 Remap: EXMC_SDNWE
PC1	9	I/O		Default: PC1 Alternate: ADC012_IN11, ETH_MDC
PC2	10	I/O		Default: PC2 Alternate: ADC012_IN12, ETH_MII_TXD2 Remap: EXMC_SDNE0, SPI1_MISO
PC3	11	I/O		Default: PC3 Alternate: ADC012_IN13, ETH_MII_TX_CLK Remap: EXMC_SDCKE0, SPI1_MOSI, I2S1_SD
VSSA	12	P		Default: VSSA
VDDA	13	P		Default: VDDA
PA0-WKUP	14	I/O		Default: PA0 Alternate: WKUP, USART1_CTS, ADC012_IN0, TIMER1_CH0, TIMER1_ETI, TIMER4_CH0, TIMER7_ETI, ETH_MII_CRS Remap: UART3_TX
PA1	15	I/O		Default: PA1 Alternate: USART1_RTS, ADC012_IN1, TIMER1_CH1, TIMER4_CH1, ETH_MII_RX_CLK, ETH_RMII_REF_CLK Remap: UART3_RX
PA2	16	I/O		Default: PA2 Alternate: USART1_TX, ADC012_IN2, TIMER1_CH2, TIMER4_CH2, TIMER8_CH0, ETH_MDIO, SPI0_IO3
PA3	17	I/O		Default: PA3 Alternate: USART1_RX, ADC012_IN3, TIMER1_CH3,

GD32F207Rx LQFP64				
Pin Name	Pins	Pin Type ⁽¹⁾	I/O Level ⁽²⁾	Functions description
				TIMER4_CH3, TIMER8_CH1, ETH_MII_COL, SPI0_IO4 Remap: TLI_B5
VSS_4	18	P		Default: VSS_4
VDD_4	19	P		Default: VDD_4
PA4	20	I/O		Default: PA4 Alternate: SPI0_NSS, USART1_CK, DAC_OUT0, ADC01_IN4, DCI_HSYNC Remap: SPI2_NSS, I2S2_WS, TLI_VSYNC
PA5	21	I/O		Default: PA5 Alternate: SPI0_SCK, ADC01_IN5, DAC_OUT1 Remap: TIMER1_CH0, TIMER1_ETI, TIMER7_CH0_ON
PA6	22	I/O		Default: PA6 Alternate: SPI0_MISO, ADC01_IN6, TIMER2_CH0, TIMER7_BRKIN, TIMER12_CH0, DCI_PIXCLK Remap: TIMER0_BRKIN, TLI_G2
PA7	23	I/O		Default: PA7 Alternate: SPI0_MOSI, ADC01_IN7, TIMER2_CH1, TIMER7_CH0_ON, TIMER13_CH0, ETH_MII_RX_DV, ETH_RMII_CRS_DV Remap: TIMER0_CH0_ON
PC4	24	I/O		Default: PC4 Alternate: ADC01_IN14, ETH_MII_RXD0, ETH_RMII_RXD0
PC5	25	I/O		Default: PC5 Alternate: ADC01_IN15, ETH_MII_RXD1, ETH_RMII_RXD1
PB0	26	I/O		Default: PB0 Alternate: ADC01_IN8, TIMER2_CH2, TIMER7_CH1_ON, ETH_MII_RXD2 Remap: TIMER0_CH1_ON, TLI_R3
PB1	27	I/O		Default: PB1 Alternate: ADC01_IN9, TIMER2_CH3, TIMER7_CH2_ON, ETH_MII_RXD3 Remap: TIMER0_CH2_ON, TLI_R6
PB2	28	I/O	5VT	Default: PB2, BOOT1
PB10	29	I/O	5VT	Default: PB10 Alternate: I2C1_SCL, USART2_TX, ETH_MII_RX_ER Remap: TIMER1_CH2, TLI_G4, SPI1_SCK, I2S1_CK
PB11	30	I/O	5VT	Default: PB11 Alternate: I2C1_SDA, USART2_RX, ETH_MII_TX_EN, ETH_RMII_TX_EN Remap: TIMER1_CH3, TLI_G5
VSS_1	31	P		Default: VSS_1
VDD_1	32	P		Default: VDD_1
PB12	33	I/O	5VT	Default: PB12 Alternate: SPI1_NSS, I2C1_SMBA, USART2_CK,

GD32F207Rx LQFP64				
Pin Name	Pins	Pin Type ⁽¹⁾	I/O Level ⁽²⁾	Functions description
				TIMER0_BRKIN, I2S1_WS, CAN1_RX, ETH_MII_TXD0, ETH_RMII_TXD0
PB13	34	I/O	5VT	Default: PB13 Alternate: SPI1_SCK, USART2_CTS, TIMER0_CH0_ON, I2S1_CK, CAN1_TX, ETH_MII_TXD1, ETH_RMII_TXD1
PB14	35	I/O	5VT	Default: PB14 Alternate: SPI1_MISO, USART2_RTS, TIMER0_CH1_ON, TIMER11_CH0
PB15	36	I/O	5VT	Default: PB15 Alternate: SPI1_MOSI, TIMER0_CH2_ON, I2S1_SD, TIMER11_CH1
PC6	37	I/O	5VT	Default: PC6 Alternate: I2S1_MCK, TIMER7_CH0, SDIO_D6, USART5_TX Remap: TIMER2_CH0, DCI_D0, TLI_HSYNC
PC7	38	I/O	5VT	Default: PC7 Alternate: I2S2_MCK, TIMER7_CH1, SDIO_D7, USART5_RX Remap: TIMER2_CH1, DCI_D1, TLI_G6
PC8	39	I/O	5VT	Default: PC8 Alternate: TIMER7_CH2, SDIO_D0, DCI_D2, USART5_CK Remap: TIMER2_CH2
PC9	40	I/O	5VT	Default: PC9 Alternate: TIMER7_CH3, SDIO_D1, DCI_D3, CK_OUT1 Remap: TIMER2_CH3, I2C2_SDA
PA8	41	I/O	5VT	Default: PA8 Alternate: USART0_CK, TIMER0_CH0, CK_OUT0, VCORE, USBFS_SOF Remap: TLI_R6, I2C2_SCL
PA9	42	I/O	5VT	Default: PA9 Alternate: USART0_TX, TIMER0_CH1, USBFS_VBUS, DCI_D0 Remap: I2C2_SMBAL
PA10	43	I/O	5VT	Default: PA10 Alternate: USART0_RX, TIMER0_CH2, USBFS_ID, DCI_D1
PA11	44	I/O	5VT	Default: PA11 Alternate: USART0_CTS, CAN0_RX, USBFS_DM, TIMER0_CH3 Remap: TLI_R4
PA12	45	I/O	5VT	Default: PA12 Alternate: USART0_RTS, USBFS_DP, CAN0_TX, TIMER0_ETI Remap: TLI_R5
PA13	46	I/O	5VT	Default: JTMS, SWDIO Remap: PA13

GD32F207Rx LQFP64				
Pin Name	Pins	Pin Type ⁽¹⁾	I/O Level ⁽²⁾	Functions description
VSS_2	47	P		Default: VSS_2
VDD_2	48	P		Default: VDD_2
PA14	49	I/O	5VT	Default: JTCK, SWCLK Remap: PA14
PA15	50	I/O	5VT	Default: JTDI Alternate: SPI2_NSS, I2S2_WS Remap: TIMER1_CH0, TIMER1_ETI, PA15, SPI0_NSS
PC10	51	I/O	5VT	Default: PC10 Alternate: UART3_TX, SDIO_D2, DCI_D8 Remap: USART2_TX, SPI2_SCK, I2S2_CK, TLI_R2
PC11	52	I/O	5VT	Default: PC11 Alternate: UART3_RX, SDIO_D3, DCI_D4 Remap: USART2_RX, SPI2_MISO
PC12	53	I/O	5VT	Default: PC12 Alternate: UART4_TX, SDIO_CK, DCI_D9 Remap: USART2_CK, SPI2_MOSI, I2S2_SD
PD2	54	I/O	5VT	Default: PD2 Alternate: TIMER2_ETI, UART4_RX, SDIO_CMD, DCI_D11
PB3	55	I/O	5VT	Default: JTDO Alternate: SPI2_SCK, I2S2_CK Remap: PB3, TRACESWO, TIMER1_CH1, SPI0_SCK
PB4	56	I/O	5VT	Default: JNTRST Alternate: SPI2_MISO Remap: TIMER2_CH0, PB4, SPI0_MISO
PB5	57	I/O		Default: PB5 Alternate: I2C0_SMBA, SPI2_MOSI, I2S2_SD, ETH_PPS_OUT, DCI_D10 Remap: TIMER2_CH1, SPI0_MOSI, CAN1_RX, EXMC_SDCKE1
PB6	58	I/O	5VT	Default: PB6 Alternate: I2C0_SCL, TIMER3_CH0, DCI_D5 Remap: USART0_TX, CAN1_TX, EXMC_SDNE1, SPI0_IO3
PB7	59	I/O	5VT	Default: PB7 Alternate: I2C0_SDA, TIMER3_CH1, EXMC_NL/EXMC_NADV, DCI_VSYNC Remap: USART0_RX, SPI0_IO4
BOOT0	60	I		Default: BOOT0
PB8	61	I/O	5VT	Default: PB8 Alternate: TIMER3_CH2, TIMER9_CH0, ETH_MII_TXD3, SDIO_D4, DCI_D6 Remap: I2C0_SCL, CAN0_RX, TLI_B6
PB9	62	I/O	5VT	Default: PB9 Alternate: TIMER3_CH3, TIMER10_CH0, SDIO_D5, DCI_D7 Remap: I2C0_SDA, CAN0_TX, TLI_B7, SPI1_NSS,

GD32F207Rx LQFP64				
Pin Name	Pins	Pin Type ⁽¹⁾	I/O Level ⁽²⁾	Functions description
				I2S1_WS
VSS_3	63	P		Default: VSS_3
VDD_3	64	P		Default: VDD_3

Notes:

- (1) Type: I = input, O = output, P = power.
- (2) I/O Level: 5VT = 5 V tolerant.

3. Functional description

3.1. ARM® Cortex®-M3 core

The Cortex®-M3 processor is the latest generation of ARM® processors for embedded systems. It has been developed to provide a low-cost platform that meets the needs of MCU implementation, with a reduced pin count and low-power consumption, while delivering outstanding computational performance and an advanced system response to interrupts.

- 32-bit ARM® Cortex®-M3 processor core
- Up to 120 MHz operation frequency
- Single-cycle multiplication and hardware divider
- Integrated Nested Vectored Interrupt Controller (NVIC)
- 24-bit SysTick timer

The Cortex®-M3 processor is based on the ARMv7 architecture and supports both Thumb and Thumb-2 instruction sets. Some system peripherals listed below are also provided by Cortex®-M3:

- Internal Bus Matrix connected with ICode bus, DCode bus, system bus, Private Peripheral Bus (PPB) and debug accesses (AHB-AP)
- Nested Vectored Interrupt Controller (NVIC)
- Flash Patch and Breakpoint (FPB)
- Data Watchpoint and Trace (DWT)
- Instrument Trace Macrocell (ITM)
- Memory Protection Unit (MPU)
- Serial Wire JTAG Debug Port (SWJ-DP)
- Trace Port Interface Unit (TPIU)

3.2. On-chip memory

- Up to 3072 Kbytes of flash memory, including code flash and data flash.
- The region of the MCU executing instructions without waiting time is up to 512K bytes (in case that Flash size equal to 256K or 512K, all memory is no waiting time. If Flash size greater than 512K, no waiting time within first 384K.). A long delay when CPU fetches the instructions out of the range.
- Up to 256 Kbytes of SRAM.

The ARM® Cortex®-M3 processor is structured in Harvard architecture which can use separate buses to fetch instructions and load/store data. 3072 Kbytes of inner flash at most, which includes code flash and data flash is available for storing programs and data, and there is no waiting time within code flash area when CPU executes instructions. Up to 256 Kbytes of inner SRAM is composed of SRAM0, SRAM1, and SRAM2 that can be accessed at same time. [Table 2-2. GD32F207xx memory map](#) shows the memory map of the GD32F207xx

series of devices, including flash, SRAM, peripheral, and other pre-defined regions.

3.3. Clock, reset and supply management

- Internal 8 MHz factory-trimmed RC and external 3 to 25 MHz crystal oscillator
- Internal 40 KHz RC calibrated oscillator and external 32.768 KHz crystal oscillator
- Integrated system clock PLL
- 2.6 to 3.6 V application supply and I/Os
- Supply Supervisor: POR (Power On Reset), PDR (Power Down Reset), and low voltage detector (LVD)

The Clock Control Unit (CCU) provides a range of oscillator and clock functions. These include speed internal RC oscillator and external crystal oscillator, high speed and low speed two types. Several prescalers allow the frequency configuration of the AHB and two APB domains. The maximum frequency of the AHB/APB2/APB1 domains is 120/120/60 MHz. See [Figure 2-6. GD32F207xx clock tree](#) for details on the clock tree.

The Reset Control Unit (RCU) controls three kinds of reset: system reset resets the processor core and peripheral IP components. Power-on reset (POR) and power-down reset (PDR) are always active, and ensures proper operation starting from 2.6 V and down to 1.8V. The device remains in reset mode when V_{DD} is below a specified threshold. The embedded low voltage detector (LVD) monitors the power supply, compares it to the voltage threshold and generates an interrupt as a warning message for leading the MCU into security.

Power supply schemes:

- V_{DD} range: 2.6 to 3.6 V, external power supply for I/Os and the internal regulator. Provided externally through V_{DD} pins.
- V_{SSA} , V_{DDA} range: 2.6 to 3.6 V, external analog power supplies for ADC, reset blocks, RCs and PLL. V_{DDA} and V_{SSA} must be connected to V_{DD} and V_{SS} , respectively.
- V_{BAT} range: 1.8 to 3.6 V, power supply for RTC, external clock 32 KHz oscillator and backup registers (through power switch) when V_{DD} is not present.

3.4. Boot modes

At startup, boot pins are used to select one of three boot options:

- Boot from main flash memory (default)
- Boot from system memory
- Boot from on-chip SRAM

The boot loader is located in the internal boot ROM memory (system memory). It is used to reprogram the flash memory by using USART0 (PA9 and PA10), USART1 (PD5 and PD6) and USB (PA9, PA10, PA11 and PA12). It also can be used to transfer and update the flash memory code, the data and the vector table sections. In default condition, boot from bank 0 of flash memory is selected. It also supports to boot from bank 1 of flash memory by setting

a bit in option bytes.

3.5. Power saving modes

The MCU supports three kinds of power saving modes to achieve even lower power consumption. They are sleep mode, deep-sleep mode, and standby mode. These operating modes reduce the power consumption and allow the application to achieve the best balance between the CPU operating time, speed and power consumption.

- **Sleep mode**

In sleep mode, only the clock of CPU core is off. All peripherals continue to operate and any interrupt/event can wake up the system.

- **Deep-sleep mode**

In deep-sleep mode, all clocks in the 1.2V domain are off, and all of the high speed crystal oscillator (IRC8M, HXTAL) and PLL are disabled. Only the contents of SRAM and registers are retained. Any interrupt or wakeup event from EXTI lines can wake up the system from the deep-sleep mode including the 16 external lines, the RTC alarm, the LVD output, the Ethernet wakeup and USB wakeup. When exiting the deep-sleep mode, the IRC8M is selected as the system clock.

- **Standby mode**

In standby mode, the whole 1.2V domain is power off, the LDO is shut down, and all of IRC8M, HXTAL and PLL are disabled. The contents of SRAM and registers (except backup registers) are lost. There are four wakeup sources for the standby mode, including the external reset from NRST pin, the RTC alarm, the FWDGT reset, and the rising edge on WKUP pin.

3.6. Analog to digital converter (ADC)

- 12-bit SAR ADC engine with up to 2 MSPS conversion rate
- 12-bit, 10-bit, 8-bit or 6-bit configurable resolution
- Hardware oversampling ratio adjustable from 2 to 256x improves resolution to 16-bit
- Conversion range: V_{SSA} to V_{DDA} (2.6 to 3.6 V)
- Temperature sensor

Up to three 12-bit 2 MSPS multi-channel ADC are integrated in the device. It is a total of up to 16 multiplexed external channels with 2 internal channels for temperature sensor and voltage reference measurement. The conversion range is between $2.6\text{ V} < V_{DDA} < 3.6\text{ V}$. An on-chip 16-bit hardware oversample scheme improves performances while off-loading the related computational burden from the MCU. An analog watchdog block can be used to detect the channels, which are required to remain within a specific threshold window. A configurable channel management block of analog inputs also can be used to perform conversions in single, continuous, scan or discontinuous mode to support more advanced usages.

The ADC can be triggered from the events generated by the general level 0 timers (TIMERx)

and the advanced timers (TIMER0 and TIMER7) with internal connection. The temperature sensor can be used to generate a voltage that varies linearly with temperature. It is internally connected to the ADC_IN16 input channel which is used to convert the sensor output voltage into a digital value.

3.7. Digital to analog converter (DAC)

- 12-bit DAC converter of independent output channel
- 8-bit or 12-bit mode in conjunction with the DMA controller

The 12-bit buffered DAC channel is used to generate variable analog outputs. The DAC is designed with integrated resistor strings structure. The DAC channels can be triggered by the timer update outputs or EXTI with DMA support. The maximum output value of the DAC is V_{REFP} .

3.8. DMA

- 14 channels DMA controller and each channel are configurable (7 for DMA0 and 7 for DMA1)
- Peripherals supported: Timers, ADC, SPIs, I2Cs, USARTs, DAC, I2S, SDIO, DCI, CAU and HAU

The flexible general-purpose DMA controllers provide a hardware method of transferring data between peripherals and/or memory without intervention from the CPU, thereby freeing up bandwidth for other system functions. Three types of access method are supported: peripheral to memory, memory to peripheral, memory to memory.

Each channel is connected to fixed hardware DMA requests. The priorities of DMA channel requests are determined by software configuration and hardware channel number. Transfer size of source and destination are independent and configurable.

3.9. General-purpose inputs/outputs (GPIOs)

- Up to 140 fast GPIOs, all mappable on 16 external interrupt lines
- Analog input/output configurable
- Alternate function input/output configurable

There are up to 140 general purpose I/O pins (GPIO) in GD32F207xx, named PA0 ~ PA15, PB0 ~ PB15, PC0 ~ PC15, PD0 ~ PD15, PE0 ~ PE15, PF0 ~ PF15, PG0 ~ PG15, PH0 ~ PH15 and PI0 ~ PI11 to implement logic input/output functions. Each of the GPIO ports has related control and configuration registers to satisfy the requirements of specific applications. The external interrupts on the GPIO pins of the device have related control and configuration registers in the Interrupt/event controller (EXTI). The GPIO ports are pin-shared with other alternative functions (AFs) to obtain maximum flexibility on the package pins. Each of the

GPIO pins can be configured by software as output (push-pull or open-drain), as input (with or without pull-up or pull-down) or as peripheral alternate function. Most of the GPIO pins are shared with digital or analog alternate functions. All GPIOs are high-current capable except for analog inputs.

3.10. Timers and PWM generation

- Two 16-bit advanced timer (TIMER0 & TIMER7), ten 16-bit general timers (TIMER1 ~ TIMER4, TIMER8 ~ TIMER13), and two 16-bit basic timer (TIMER5 & TIMER6)
- Up to 4 independent channels of PWM, output compare or input capture for each general timer and external trigger input
- 16-bit, motor control PWM advanced timer with programmable dead-time generation for output match
- Encoder interface controller with two inputs using quadrature decoder
- 24-bit SysTick timer down counter
- 2 watchdog timers (free watchdog timer and window watchdog timer)

The advanced timer (TIMER0 & TIMER7) can be used as a three-phase PWM multiplexed on 6 channels. It has complementary PWM outputs with programmable dead-time generation. It can also be used as a complete general timer. The 4 independent channels can be used for input capture, output compare, PWM generation (edge- or center-aligned counting modes) and single pulse mode output. If configured as a 16-bit general timer, it has the same functions as the TIMERx timer. It can be synchronized with external signals or to interconnect with other general timers together which have the same architecture and features.

The general timer, known as TIMER1 ~ TIMER4, TIMER8 ~ TIMER13 can be used for a variety of purposes including general time, input signal pulse width measurement or output waveform generation such as a single pulse generation or PWM output, up to 4 independent channels for input capture/output compare. The general timer is based on a 16-bit auto-reload up/down counter and a 16-bit prescaler. TIMER1 ~ TIMER4 and TIMER8/TIMER11 also supports an encoder interface with two inputs using quadrature decoder.

The basic timer, known as TIMER5 & TIMER6, are mainly used for DAC trigger generation. They can also be used as a simple 16-bit time base.

The GD32F207xx have two watchdog peripherals, free watchdog timer and window watchdog timer. They offer a combination of high safety level, flexibility of use and timing accuracy.

The free watchdog timer includes a 12-bit down-counting counter and an 8-bit prescaler, it is clocked from an independent 40 KHz internal RC and as it operates independently of the main clock, it can operate in deep-sleep and standby modes. It can be used either as a watchdog to reset the device when a problem occurs, or as a free-running timer for application timeout management.

The window watchdog timer is based on a 7-bit down counter that can be set as free-running. It can be used as a watchdog to reset the device when a problem occurs. It is clocked from

the main clock. It has an early wakeup interrupt capability and the counter can be frozen in debug mode.

The SysTick timer is dedicated for OS, but could also be used as a standard down counter.

The features are shown below:

- A 24-bit down counter
- Auto reload capability
- Maskable system interrupt generation when the counter reaches 0
- Programmable clock source

3.11. Real time clock (RTC) and backup registers

- 32-bit up-counter with a programmable 20-bit prescaler
- Alarm function
- Interrupt and wake-up event
- 84 bytes backup registers for data protection

The real time clock is an independent timer which provides a set of continuously running counters in backup registers to provide a real calendar function, and provides an alarm interrupt or an expected interrupt. It is not reset by a system or power reset, or when the device wakes up from standby mode. A 20-bit prescaler is used for the time base clock and is by default configured to generate a time base of 1 second from a clock at 32.768 KHz from external crystal oscillator.

The backup registers are located in the backup domain that remains powered-on by V_{BAT} even if V_{DD} power is shut down, they are forty two 16-bit (84 bytes) registers for data protection of user application data, and the wake-up action from standby mode or system reset do not affect these registers.

In addition, the backup registers can be used to implement the tamper detection, RTC calibration function and waveform detection.

3.12. Inter-integrated circuit (I2C)

- Up to three I2C bus interfaces can support both master and slave mode with a frequency up to 400 KHz
- Provide arbitration function, optional PEC (packet error checking) generation and checking
- Supports 7-bit and 10-bit addressing mode and general call addressing mode

The I2C interface is an internal circuit allowing communication with an external I2C interface which is an industry standard two line serial interface used for connection to external hardware. These two serial lines are known as a serial data line (SDA) and a serial clock line (SCL). The I2C module provides transfer rate of up to 100 KHz in standard mode and up to 400 KHz in fast mode. The I2C module also has an arbitration detect function to prevent the

situation where more than one master attempts to transmit data to the I2C bus at the same time. A CRC-8 calculator is also provided in I2C interface to perform packet error checking for I2C data.

3.13. Serial peripheral interface (SPI)

- Up to three SPI interfaces with a frequency of up to 30 MHz
- Support both master and slave mode
- Hardware CRC calculation and transmit automatic CRC error checking
- Quad wire configuration available in master mode (only in SPI0)

The SPI interface uses 4 pins, among which are the serial data input and output lines (MISO & MOSI), the clock line (SCK) and the slave select line (NSS). Both SPIs can be served by the DMA controller. The SPI interface may be used for a variety of purposes, including simplex synchronous transfers on two lines with a possible bidirectional data line or reliable communication using CRC checking. Quad-SPI master mode is also supported in SPI0.

3.14. Universal synchronous/asynchronous receiver transmitter (USART/UART)

- Up to four USARTs and four UARTs with operating frequency up to 7.5 MHz
- Supports both asynchronous and clocked synchronous serial communication modes
- IrDA SIR encoder and decoder support
- LIN break generation and detection
- ISO 7816-3 compliant smart card interface

The USART (USART0, USART1, USART2, USART5) and UART (UART3, UART4, UART6, UART7) are used to transmit data between parallel and serial interfaces, provides a flexible full duplex data exchange using synchronous or asynchronous transfer. It is also commonly used for RS-232 standard communication. The USART/UART includes a programmable baud rate generator which is capable of dividing the system clock to produce a dedicated clock for the USART/UART transmitter and receiver. The USART/UART also supports DMA function for high speed data communication.

3.15. Inter-IC sound (I2S)

- Two I2S bus Interfaces with sampling frequency from 8 KHz to 192 KHz, multiplexed with SPI1 and SPI2
- Support either master or slave mode audio
- Sampling frequencies from 8 KHz up to 192 KHz are supported.

The Inter-IC sound (I2S) bus provides a standard communication interface for digital audio

applications by 3-wire serial lines. GD32F207xx contain an I2S-bus interface that can be operated with 16/32-bit resolution in master or slave mode, pin multiplexed with SPI1 and SPI2. The audio sampling frequencies from 8 KHz to 192 KHz is supported with less than 0.5% accuracy error.

3.16. Universal serial bus full-speed interface (USBFS)

- One USB device/host full-speed Interface with frequency up to 12 Mbit/s
- Internal main PLL for USB CLK compliantly

The Universal Serial Bus (USB) is a 4-wire bus with 4 bidirectional endpoints. The device controller enables 12 Mbit/s data exchange with integrated transceivers in device/host mode. Full-speed peripheral is compliant with the USB 2.0 specification. Transaction formatting is performed by the hardware, including CRC generation and checking. The status of a completed USB transfer or error condition is indicated by status registers. An interrupt is also generated if enabled. The dedicated 48 MHz clock is generated from the internal main PLL (the clock source must use a HXTAL crystal oscillator) and the operating frequency divided from APB1 should be 12 MHz above.

3.17. Controller area network (CAN)

- Two CAN2.0B interface with communication frequency up to 1 Mbit/s
- Internal main PLL for CAN CLK compliantly

Controller area network (CAN) is a method for enabling serial communication in field bus. The CAN protocol has been used extensively in industrial automation and automotive applications. It can receive and transmit standard frames with 11-bit identifiers as well as extended frames with 29-bit identifiers. Each CAN has three mailboxes for transmission and two FIFOs of three message deep for reception. It also provides 28 scalable/configurable identifier filter banks for selecting the incoming messages needed and discarding the others.

3.18. Ethernet (ENET)

- IEEE 802.3 compliant media access controller (MAC) for Ethernet LAN
- 10/100 Mbit/s rates with dedicated DMA controller and SRAM
- Support hardware precision time protocol (PTP) with conformity to IEEE 1588

The Ethernet media access controller (MAC) conforms to IEEE 802.3 specifications and fully supports IEEE 1588 standards. The embedded MAC provides the interface to the required external network physical interface (PHY) for LAN bus connection via an internal media independent interface (MII) or a reduced media independent interface (RMII). The number of MII signals provided up to 16 with 25 MHz output and RMII up to 7 with 50 MHz output. The function of 32-bit CRC checking is also available.

3.19. External memory controller (EXMC)

- Supported external memory: SRAM, PSRAM, ROM and NOR-Flash, NAND Flash and PC card, SDRAM with up to 32-bit data bus
- Provide ECC calculating hardware module for NAND Flash memory block
- Two SDRAM banks with independent configuration, up to 13-bits Row Address, 11-bits Column Address, 2-bits internal banks address
- SDRAM Memory size: 4x16Mx32bit(256 MB), 4x16Mx16bit (128 MB), 4x16Mx8bit (64 MB)

External memory controller (EXMC) is an abbreviation of external memory controller. It is divided into several sub-banks for external device support, each sub-bank has its own chip selection signal but at one time, only one bank can be accessed. The EXMC support code execution from external memory except NAND Flash and PC card. The EXMC also can be configured to interface with the most common LCD module of Motorola 6800 and Intel 8080 series and reduce the system cost and complexity.

The EXMC of GD32F207xx in LQFP144 package above also supports synchronous dynamic random access memory (SDRAM). It translates AHB transactions into the appropriate SDRAM protocol, and meanwhile, makes sure the access time requirements of the external SDRAM devices are satisfied.

3.20. Secure digital input and output card interface (SDIO)

- Support SD2.0/SDIO2.0/MMC4.2 host interface

The Secure Digital Input and Output Card Interface (SDIO) provides access to external SD memory cards specifications version 2.0, SDIO card specification version 2.0 and multi-media card system specification version 4.2 with DMA supported. In addition, this interface is also compliant with CE-ATA digital protocol rev1.1.

3.21. TFT LCD interface (TLI)

- 24-bit RGB Parallel Pixel Output; 8 bits-per-pixel (RGB888)
- Supports up to SVGA (800x600) resolution

The TFT LCD interface provides a parallel digital RGB (Red, Green, Blue) and signals for horizontal, vertical synchronization, pixel clock and data enable as output to interface directly to a variety of LCD (Liquid Crystal Display) and TFT (Thin Film Transistor) panels. A built-in DMA engine continuously move data from system memory to TLI and then, output to an external LCD display. Two separate layers are supported in TLI, as well as layer window and blending function.

3.22. Digital camera interface (DCI)

- Digital video/picture capture
- 8/10/12/14 data width supported
- High transfer efficiency with DMA interface
- Video/picture crop supported
- Various pixel formats supported including JPEG/YCrCb/RGB
- Hard/embedded synchronous signals supported

DCI is an 8-bit to 14-bit parallel interface that able to capture video or picture from a camera via Digital Camera Interface. It supports 8/10/12/14 bits data width through DMA operation.

3.23. Cryptographic acceleration Unit (CAU)

- Supports DES, 3DES or AES algorithm
- DES/3DES supports Electronic codebook (ECB) or Cipher block chaining (CBC) mode
- 3DES supports 64bits-key, 128bits-key or 192bits-key
- AES supports 128bits-key, 192bits-key or 256 bits-key
- AES supports Electronic codebook (ECB), Cipher block chaining (CBC) mode or Counter mode (CTR) mode
- Support DMA mode for input data flow

The Cryptographic Acceleration Unit supports acceleration of DES, 3DES or AES (128, 192, or 256) algorithms. The DES/3DES supports Electronic codebook (ECB) or Cipher block chaining (CBC) mode. The AES supports Electronic codebook (ECB), Cipher block chaining (CBC) mode or Counter mode (CTR) mode.

3.24. Hash acceleration unit (HAU)

- Supports SHA-1, SHA-224 and SHA-256 algorithms, compliant with FIPS PUB 180-2 (Federal Information Processing Standards Publication 180-2)
- Supports MD5 compliant with IETF RFC 1321 (Internet Engineering Task Force Request For Comments number 1321)
- Supports HMAC (keyed-hash message authentication code) algorithm
- Automatic swapping to comply with the big-endian or little-endian for MD5, SHA-1, SHA-224 and SHA-256 algorithms
- Automatic padding to fit module 512
- Support DMA mode for input data flow

The HAU supports acceleration of SHA-1, SHA-224, SHA-256, MD5 algorithm and the HMAC (keyed-hash message authentication code) algorithm, which calling the SHA-1, SHA-224, SHA-256 or MD5 hash function to calculate key, message, digest three times.

3.25. True Random number generator (TRNG)

- About 40 period PLL clock consumed between two consecutive random numbers
- Disable TRNG module will reduce the chip power consumption
- 32-bit random value seed is generated from analog noise

The true random number generator (TRNG) module can generate a 32-bit value using continuous analog noise.

3.26. Debug mode

- Serial wire JTAG debug port (SWJ-DP)

The ARM® SWJ-DP Interface is embedded and is a combined JTAG and serial wire debug port that enables either a serial wire debug or a JTAG probe to be connected to the target.

3.27. Package and operation temperature

- LQFP176 (GD32F207Ix), LQFP144 (GD32F207Zx), LQFP100 (GD32F207Vx), LQFP64 (GD32F207Rx)
- Operation temperature range: -40°C to +85°C (industrial level)

4. Electrical characteristics

4.1. Absolute maximum ratings

The maximum ratings are the limits to which the device can be subjected without permanently damaging the device. Note that the device is not guaranteed to operate properly at the maximum ratings. Exposure to the absolute maximum rating conditions for extended periods may affect device reliability.

Table 4-1. Absolute maximum ratings ⁽¹⁾⁽⁴⁾

Symbol	Parameter	Min	Max	Unit
V _{DD}	External voltage range ⁽²⁾	V _{SS} - 0.3	V _{SS} + 3.6	V
V _{DDA}	External analog supply voltage	V _{SSA} - 0.3	V _{SSA} + 3.6	V
V _{BAT}	External battery supply voltage	V _{SS} - 0.3	V _{SS} + 3.6	V
V _{IN}	Input voltage on 5V tolerant pin ⁽³⁾	V _{SS} - 0.3	V _{DD} + 3.6	V
	Input voltage on other I/O	V _{SS} - 0.3	3.6	V
ΔV _{DDX}	Variations between different VDD power pins	—	50	mV
V _{SSX} - V _{SS}	Variations between different ground pins	—	50	mV
I _{IO}	Maximum current for GPIO pins	—	±25	mA
T _A	Operating temperature range	-40	+85	°C
P _D	Power dissipation at T _A = 85°C of LQFP176	—	—	mW
	Power dissipation at T _A = 85°C of LQFP144	—	820	
	Power dissipation at T _A = 85°C of LQFP100	—	697	
	Power dissipation at T _A = 85°C of LQFP64	—	647	
T _{STG}	Storage temperature range	-65	+150	°C
T _J	Maximum junction temperature	—	125	°C

(1) Guaranteed by design, not tested in production.

(2) All main power and ground pins should be connected to an external power source within the allowable range.

(3) V_{IN} maximum value cannot exceed 5.5 V.

(4) It is recommended that V_{DD} and V_{DDA} are powered by the same source. The maximum difference between V_{DD} and V_{DDA} does not exceed 300 mV during power-up and operation.

4.2. Recommended DC characteristics

Table 4-2. DC operating conditions

Symbol	Parameter	Conditions	Min ⁽¹⁾	Typ	Max ⁽¹⁾	Unit
V _{DD}	Supply voltage	—	2.6	3.3	3.6	V
V _{DDA}	Analog supply voltage	Same as V _{DD}	2.6	3.3	3.6	V
V _{BAT}	Battery supply voltage	—	1.8 ⁽²⁾	—	3.6	V

(1) Based on characterization, not tested in production.

(2) In the application which V_{BAT} supply the backup domains, if the V_{BAT} voltage drops below the minimum value, when V_{DD} is powered on again, it is necessary to refresh the registers of backup domains and enable LXTAL again.

Figure 4-1. Recommended power supply decoupling capacitors ⁽¹⁾⁽²⁾

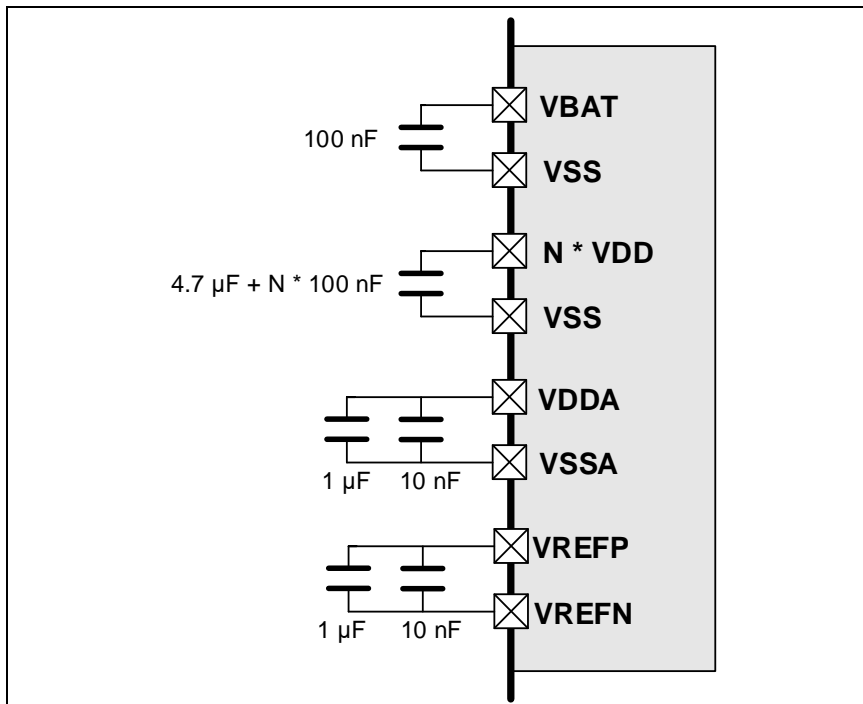

- (1) The VREFP and VREFN pins are only available on no less than 100-pin packages, or else the VREFP and VREFN pins are not available and internally connected to VDDA and VSSA pins.
- (2) All decoupling capacitors need to be as close as possible to the pins on the PCB board.

Table 4-3. Clock frequency ⁽¹⁾

Symbol	Parameter	Conditions	Min	Max	Unit
f _{HCLK}	AHB clock frequency	—	—	120	MHz
f _{APB1}	APB1 clock frequency	—	—	60	MHz
f _{APB2}	APB2 clock frequency	—	—	120	MHz

- (1) Guaranteed by design, not tested in production.

Table 4-4. Operating conditions at Power up/ Power down ⁽¹⁾

Symbol	Parameter	Conditions	Min	Max	Unit
t _{VDD}	V _{DD} rise time rate	—	0	∞	μs/V
	V _{DD} fall time rate		20	∞	

- (1) Guaranteed by design, not tested in production.

Table 4-5. Start-up timings of Operating conditions ⁽¹⁾⁽²⁾⁽³⁾

Symbol	Parameter	Conditions	Typ	Unit
t _{start-up}	Start-up time	Clock source from HXTAL	246	ms
		Clock source from IRC8M	246	

- (1) Based on characterization, not tested in production.
- (2) After power-up, the start-up time is the time between the rising edge of NRST high and the main function.
- (3) PLL is off.

Table 4-6. Power saving mode wakeup timings characteristics ⁽¹⁾⁽²⁾

Symbol	Parameter	Typ	Unit
t_{Sleep}	Wakeup from Sleep mode	3.64	μs
$t_{\text{Deep-sleep}}$	Wakeup from Deep-sleep mode (LDO On)	5.19	
	Wakeup from Deep-sleep mode (LDO in low power mode)	5.19	
t_{Standby}	Wakeup from Standby mode	192	ms

(1) Based on characterization, not tested in production.

(2) The wakeup time is measured from the wakeup event to the point at which the application code reads the first instruction under the below conditions: $V_{\text{DD}} = V_{\text{DDA}} = 3.3\text{ V}$, IRC8M = System clock = 8 MHz.

4.3. Power consumption

The power measurements specified in the tables represent that code with data executing from on-chip Flash with the following specifications.

Table 4-7. Power consumption characteristics ⁽²⁾⁽³⁾⁽⁴⁾⁽⁵⁾⁽⁶⁾

Symbol	Parameter	Conditions	Min	Typ ⁽¹⁾	Max	Unit
$I_{\text{DD}} + I_{\text{DDA}}$	Supply current (Run mode)	$V_{\text{DD}}=V_{\text{DDA}}=3.3\text{V}$, HXTAL=25MHz, System clock=120 MHz, All peripherals enabled	—	130.15	—	mA
		$V_{\text{DD}}=V_{\text{DDA}}=3.3\text{V}$, HXTAL=25MHz, System clock =120 MHz, All peripherals disabled	—	56.43	—	mA
		$V_{\text{DD}}=V_{\text{DDA}}=3.3\text{V}$, HXTAL=25MHz, System clock=108 MHz, All peripherals enabled	—	117.45	—	mA
		$V_{\text{DD}}=V_{\text{DDA}}=3.3\text{V}$, HXTAL=25MHz, System clock =108 MHz, All peripherals disabled	—	51.07	—	mA
		$V_{\text{DD}}=V_{\text{DDA}}=3.3\text{V}$, HXTAL=25MHz, System clock =72MHz, All peripherals enabled	—	79.03	—	mA
		$V_{\text{DD}}=V_{\text{DDA}}=3.3\text{V}$, HXTAL=25MHz, System Clock =72 MHz, All peripherals disabled	—	35.05	—	mA
	Supply current (Sleep mode)	$V_{\text{DD}}=V_{\text{DDA}}=3.3\text{V}$, HXTAL=25MHz, CPU clock off, System clock=120 MHz, All peripherals enabled	—	93.05	—	mA
		$V_{\text{DD}}=V_{\text{DDA}}=3.3\text{V}$, HXTAL=25MHz, CPU clock off, System clock=120 MHz, All peripherals disabled	—	12.54	—	mA
	Supply current (Deep-Sleep mode)	$V_{\text{DD}}=V_{\text{DDA}}=3.3\text{V}$, LDO in Run mode, IRC40K on, RTC on	—	1.21	—	mA
		$V_{\text{DD}}=V_{\text{DDA}}=3.3\text{V}$, LDO in Low Power mode, IRC40K on, RTC on	—	1.18	—	mA
		$V_{\text{DD}}=V_{\text{DDA}}=3.3\text{V}$, LDO in Run mode, IRC40K off, RTC off	—	1.02	—	mA
	Supply current (Standby mode)	$V_{\text{DD}}=V_{\text{DDA}}=3.3\text{V}$, LXTAL off, IRC40K on, RTC on	—	7.47	—	μA
		$V_{\text{DD}}=V_{\text{DDA}}=3.3\text{V}$, LXTAL off, IRC40K on, RTC off	—	7.35	—	μA
$V_{\text{DD}}=V_{\text{DDA}}=3.3\text{V}$, LXTAL off, IRC40K off, RTC off		—	6.02	27.5	μA	
I_{BAT}	Battery supply current	$V_{\text{BAT}}=3.6\text{V}$, LXTAL on, RTC on, LXTAL High driving	—	1.65	—	μA
		$V_{\text{BAT}}=3.3\text{V}$, LXTAL on, RTC on, LXTAL High driving	—	1.55	—	μA

Symbol	Parameter	Conditions	Min	Typ ⁽¹⁾	Max	Unit
		V _{BAT} =2.6V, LXTAL on, RTC on, LXTAL High driving	—	1.40	—	μA
		V _{BAT} =3.6V, LXTAL on, RTC on, LXTAL Mid High driving	—	1.22	—	μA
		V _{BAT} =3.3V, LXTAL on, RTC on, LXTAL Mid High driving	—	1.13	—	μA
		V _{BAT} =2.6V, LXTAL on, RTC on, LXTAL Mid High driving	—	0.98	—	μA
		V _{BAT} =3.6V, LXTAL on, RTC on, LXTAL Mid Low driving	—	0.97	—	μA
		V _{BAT} =3.3V, LXTAL on, RTC on, LXTAL Mid Low driving	—	0.87	—	μA
		V _{BAT} =2.6V, LXTAL on, RTC on, LXTAL Mid Low driving	—	0.70	—	μA

- (1) Based on characterization, not tested in production.
- (2) Unless otherwise specified, all values given for T_A = 25 °C and test result is mean value.
- (3) When System Clock is less than 4 MHz, an external source is used, and the HXTAL bypass function is needed, no PLL.
- (4) When System Clock is greater than 8 MHz, a crystal 8 MHz is used, and the HXTAL bypass function is closed, using PLL.
- (5) When analog peripheral blocks such as ADCs, DACs, HXTAL, LXTAL, IRC8M, or IRC40K are ON, an additional power consumption should be considered.
- (6) All GPIOs are configured as analog mode except standby mode.

4.4. EMC characteristics

EMS (electromagnetic susceptibility) includes ESD (Electrostatic discharge, positive and negative) and FTB (Burst of Fast Transient voltage, positive and negative) testing result is given in [Table 4-8. EMS characteristics](#), based on the EMS levels and classes compliant with IEC 61000 series standard.

Table 4-8. EMS characteristics ⁽¹⁾

Symbol	Parameter	Conditions	Level/Class
V _{ESD}	Voltage applied to all device pins to induce a functional disturbance	V _{DD} = 3.3 V, T _A = +25 °C conforms to IEC 61000-4-2	3B
V _{FTB}	Fast transient voltage burst applied to induce a functional disturbance through 100 pF on VDD and VSS pins	V _{DD} = 3.3 V, T _A = +25 °C conforms to IEC 61000-4-4	4A

- (1) Based on characterization, not tested in production.

4.5. Power supply supervisor characteristics

Table 4-9. Power supply supervisor characteristics

Symbol	Parameter	Conditions	Min	Typ	Max	Unit
V _{LVD} ⁽¹⁾	Low voltage Detector level selection	LVDT<2:0> = 000(rising edge)	—	2.19	—	V
		LVDT<2:0> = 000(falling edge)	—	2.08	—	
		LVDT<2:0> = 001(rising edge)	—	2.29	—	
		LVDT<2:0> = 001(falling edge)	—	2.19	—	
		LVDT<2:0> = 010(rising edge)	—	2.39	—	
		LVDT<2:0> = 010(falling edge)	—	2.29	—	
		LVDT<2:0> = 011(rising edge)	—	2.5	—	
		LVDT<2:0> = 011(falling edge)	—	2.39	—	
		LVDT<2:0> = 100(rising edge)	—	2.6	—	
		LVDT<2:0> = 100(falling edge)	—	2.48	—	
		LVDT<2:0> = 101(rising edge)	—	2.68	—	
		LVDT<2:0> = 101(falling edge)	—	2.58	—	
		LVDT<2:0> = 110(rising edge)	—	2.79	—	
		LVDT<2:0> = 110(falling edge)	—	2.68	—	
LVDT<2:0> = 111(rising edge)	—	2.89	—			
LVDT<2:0> = 111(falling edge)	—	2.78	—			
V _{LVDhyst} ⁽²⁾	LVD hysteresis	—	—	100	—	mV
V _{POR} ⁽¹⁾	Power on reset threshold	—	—	2.46	—	V
V _{PDR} ⁽¹⁾	Power down reset threshold		—	1.87	—	V
V _{PDRhyst} ⁽²⁾	PDR hysteresis		—	600	—	mV
t _{RSTTEMPO} ⁽²⁾	Reset temporization		—	2	—	ms

(1) Based on characterization, not tested in production.

(2) Guaranteed by design, not tested in production.

4.6. Electrical sensitivity

The device is strained in order to determine its performance in terms of electrical sensitivity. Electrostatic discharges (ESD) are applied directly to the pins of the sample. Static latch-up

(LU) test is based on the two measurement methods.

Table 4-10. ESD characteristics

Symbol	Parameter	Conditions	Min	Typ	Max	Unit
$V_{ESD(HBM)}$	Electrostatic discharge voltage (human body model)	$T_A=25\text{ }^\circ\text{C}$; JS-001-2014	—	—	5000	V
$V_{ESD(CDM)}$	Electrostatic discharge voltage (charge device model)	$T_A=25\text{ }^\circ\text{C}$; JS-002-2014	—	—	500	V

Table 4-11. Static latch-up characteristics

Symbol	Parameter	Conditions	Min	Typ	Max	Unit
LU	I-test	$T_A=25\text{ }^\circ\text{C}$; JESD78	—	—	± 100	mA
	V_{supply} over voltage		—	—	5.4	V

4.7. External clock characteristics

Table 4-12. High speed external clock (HXTAL) generated from a crystal/ceramic characteristics

Symbol	Parameter	Conditions	Min	Typ	Max	Unit
$f_{\text{HXTAL}}^{(1)}$	Crystal or ceramic frequency	$2.6\text{ V} \leq V_{\text{DD}} \leq 3.6\text{ V}$	4	25	32	MHz
$R_F^{(2)}$	Feedback resistor	$V_{\text{DD}} = 3.3\text{ V}$	—	400	—	k Ω
$C_{\text{HXTAL}}^{(2)(3)}$	Recommended matching capacitance on OSCIN and OSCOUT	—	—	20	30	pF
$D_{\text{ucy}}^{(\text{HXTAL})^{(2)}}$	Crystal or ceramic duty cycle	—	30	50	70	%
$g_m^{(2)}$	Oscillator transconductance	Startup	—	25	—	mA/V
$I_{\text{DDHXTAL}}^{(1)}$	Crystal or ceramic operating current	$V_{\text{DD}} = 3.3\text{ V}$, $T_A = 25\text{ }^\circ\text{C}$	—	1.69	—	mA
$t_{\text{SUHXTAL}}^{(1)}$	Crystal or ceramic startup time	$V_{\text{DD}} = 3.3\text{ V}$, $T_A = 25\text{ }^\circ\text{C}$	—	0.46	—	ms

(1) Based on characterization, not tested in production.

(2) Guaranteed by design, not tested in production.

(3) $C_{\text{HXTAL1}} = C_{\text{HXTAL2}} = 2 * (C_{\text{LOAD}} - C_S)$, For C_{HXTAL1} and C_{HXTAL2} , it is recommended matching capacitance on OSCIN and OSCOUT. For C_{LOAD} , it is crystal/ceramic load capacitance, provided by the crystal or ceramic manufacturer. For C_S , it is PCB and MCU pin stray capacitance.

Table 4-13. High speed external clock characteristics (HXTAL in bypass mode)

Symbol	Parameter	Conditions	Min	Typ	Max	Unit
$f_{\text{HXTAL_ext}}^{(1)}$	External clock source or oscillator frequency	$V_{\text{DD}} = 3.3\text{ V}$	1	—	50	MHz
$V_{\text{HXTALH}}^{(2)}$	OSCIN input pin high level voltage	$V_{\text{DD}} = 3.3\text{ V}$	$0.7 V_{\text{DD}}$	—	V_{DD}	V

Symbol	Parameter	Conditions	Min	Typ	Max	Unit
$V_{\text{HXTALL}}^{(2)}$	OSCIN input pin low level voltage		V_{SS}	—	$0.3 V_{\text{DD}}$	V
$t_{\text{H/L(HXTAL)}}^{(2)}$	OSCIN high or low time	—	5	—	—	ns
$t_{\text{R/F(HXTAL)}}^{(2)}$	OSCIN rise or fall time	—	—	—	10	ns
$C_{\text{IN}}^{(2)}$	OSCIN input capacitance	—	—	5	—	pF
$\text{Ducy}_{(\text{HXTAL})}^{(2)}$	Duty cycle	—	40	—	60	%

(1) Based on characterization, not tested in production.

(2) Guaranteed by design, not tested in production.

Table 4-14. Low speed external clock (LXTAL) generated from a crystal/ceramic characteristics

Symbol	Parameter	Conditions	Min	Typ	Max	Unit
$f_{\text{LXTAL}}^{(1)}$	Crystal or ceramic frequency	$V_{\text{DD}} = 3.3 \text{ V}$	—	32.768	—	kHz
$C_{\text{LXTAL}}^{(2)(3)}$	Recommended matching capacitance on OSC32IN and OSC32OUT	—	—	15	—	pF
$\text{Ducy}_{(\text{LXTAL})}^{(2)}$	Crystal or ceramic duty cycle	—	30	—	70	%
$g_{\text{m}}^{(2)}$	Oscillator transconductance	Lower driving capability	—	4	—	$\mu\text{A/V}$
		Medium low driving capability	—	6	—	
		Medium high driving capability	—	12	—	
		Higher driving capability	—	18	—	
$I_{\text{DDLXTAL}}^{(1)}$	LXTAL oscillator operating current	$\text{LXTALDRI}[1:0]=10$	—	1.14	—	μA
		$\text{LXTALDRI}[1:0]=11$	—	1.65	—	
$t_{\text{SULXTAL}}^{(1)(4)}$	LXTAL oscillator startup time	$\text{LXTALDRI}[1:0]=10$	—	0.56	—	s
		$\text{LXTALDRI}[1:0]=11$	—	0.4	—	

(1) Based on characterization, not tested in production.

(2) Guaranteed by design, not tested in production.

(3) $C_{\text{LXTAL1}} = C_{\text{LXTAL2}} = 2 * (C_{\text{LOAD}} - C_{\text{S}})$, For C_{LXTAL1} and C_{LXTAL2} , it is recommended matching capacitance on OSC32IN and OSC32OUT. For C_{LOAD} , it is crystal/ceramic load capacitance, provided by the crystal or ceramic manufacturer. For C_{S} , it is PCB and MCU pin stray capacitance.

(4) t_{SULXTAL} is the startup time measured from the moment it is enabled (by software) to the 32.768 kHz oscillator stabilization flags is SET. This value varies significantly with the crystal manufacturer.

Table 4-15. Low speed external user clock characteristics (LXTAL in bypass mode)

Symbol	Parameter	Conditions	Min	Typ	Max	Unit
$f_{\text{LXTAL_ext}}^{(1)}$	External clock source or oscillator frequency	$V_{\text{DD}} = 3.3 \text{ V}$	—	32.768	1000	kHz
$V_{\text{LXTALH}}^{(2)}$	OSC32IN input pin high level voltage	—	$0.7 V_{\text{DD}}$	—	V_{DD}	V
$V_{\text{LXTALL}}^{(2)}$	OSC32IN input pin low level voltage	—	V_{SS}	—	$0.3 V_{\text{DD}}$	

Symbol	Parameter	Conditions	Min	Typ	Max	Unit
$t_{H/L(LXTAL)}^{(2)}$	OSC32IN high or low time	—	450	—	—	ns
$t_{R/F(LXTAL)}^{(2)}$	OSC32IN rise or fall time	—	—	—	50	
$C_{IN}^{(2)}$	OSC32IN input capacitance	—	—	5	—	pF
$Ducy(LXTAL)^{(2)}$	Duty cycle	—	30	50	70	%

(1) Based on characterization, not tested in production.

(2) Guaranteed by design, not tested in production.

4.8. Internal clock characteristics

Table 4-16. High speed internal clock (IRC8M) characteristics

Symbol	Parameter	Conditions	Min	Typ	Max	Unit
f_{IRC8M}	High Speed Internal Oscillator (IRC8M) frequency	$V_{DD} = V_{DDA} = 3.3 V$	—	8	—	MHz
ACC_{IRC8M}	IRC8M oscillator Frequency accuracy, Factory-trimmed	$V_{DD} = V_{DDA} = 3.3 V$, $T_A = -40\text{ }^\circ\text{C} \sim +85\text{ }^\circ\text{C}^{(1)}$	—	-0.9 to 0.4	—	%
		$V_{DD} = V_{DDA} = 3.3 V$, $T_A = 25\text{ }^\circ\text{C}$	-1.0	—	+1.0	%
	IRC8M oscillator Frequency accuracy, User trimming step ⁽¹⁾	—	—	0.5	—	%
$Ducy_{IRC8M}^{(2)}$	IRC8M oscillator duty cycle	$V_{DD} = V_{DDA} = 3.3 V$	45	50	55	%
$I_{DDAIRC8M}^{(1)}$	IRC8M oscillator operating current	$V_{DD} = V_{DDA} = 3.3 V$, $f_{IRC8M} = 8\text{ MHz}$	—	75	100	μA
$t_{SUIRC8M}^{(1)}$	IRC8M oscillator startup time	$V_{DD} = V_{DDA} = 3.3 V$, $f_{IRC8M} = 8\text{ MHz}$	1	1.87	2	μs

(1) Based on characterization, not tested in production.

(2) Guaranteed by design, not tested in production.

Table 4-17. Low speed internal clock (IRC40K) characteristics

Symbol	Parameter	Conditions	Min	Typ	Max	Unit
$f_{IRC40K}^{(1)}$	Low Speed Internal oscillator (IRC40K) frequency	$V_{DD} = V_{DDA} = 3.3 V$, $T_A = -40\text{ }^\circ\text{C} \sim +85\text{ }^\circ\text{C}$	—	40	—	kHz
$I_{DDAIRC40K}^{(2)}$	IRC40K oscillator operating current	$V_{DD} = V_{DDA} = 3.3 V$, $T_A = 25\text{ }^\circ\text{C}$	—	1	—	μA
$t_{SUIRC40K}^{(2)}$	IRC40K oscillator startup time	$V_{DD} = V_{DDA} = 3.3 V$, $T_A = 25\text{ }^\circ\text{C}$	—	109	—	μs

(1) Guaranteed by design, not tested in production.

(2) Based on characterization, not tested in production.

4.9. PLL characteristics

Table 4-18. PLL characteristics

Symbol	Parameter	Conditions	Min	Typ	Max	Unit
$f_{PLLIN}^{(1)}$	PLL input clock frequency	—	1	—	25	MHz
$f_{PLLOUT}^{(2)}$	PLL output clock frequency	—	16	—	120	MHz
$f_{VCO}^{(2)}$	PLL VCO output clock frequency	—	32	—	240	MHz
$t_{LOCK}^{(2)}$	PLL lock time	—	—	—	300	μ s
$I_{DDA}^{(1)}$	Current consumption on V_{DDA}	VCO freq = 240 MHz	—	450	—	μ A
$Jitter_{PLL}^{(1)(3)}$	Cycle to cycle Jitter (rms)	System clock	—	35	—	ps
	Cycle to cycle Jitter (peak to peak)		—	371	—	

(1) Based on characterization, not tested in production.

(2) Guaranteed by design, not tested in production.

(3) Value given with main PLL running.

4.10. Memory characteristics

Table 4-19. Flash memory characteristics

Symbol	Parameter	Conditions	Min ⁽¹⁾	Typ ⁽¹⁾	Max ⁽²⁾	Unit
PE_{CYC}	Number of guaranteed program /erase cycles before failure (Endurance)	$T_A = -40^{\circ}\text{C} \sim +85^{\circ}\text{C}$	100	—	—	kcycles
t_{RET}	Data retention time	—	—	20	—	years
t_{PROG}	Word programming time	$T_A = -40^{\circ}\text{C} \sim +85^{\circ}\text{C}$	—	37.5	170	μ s
t_{ERASE}	Page erase time	$T_A = -40^{\circ}\text{C} \sim +85^{\circ}\text{C}$	—	50	500	ms
$t_{MERASE(256K)}$	Mass erase time	$T_A = -40^{\circ}\text{C} \sim +85^{\circ}\text{C}$	—	4	32	s
$t_{MERASE(512K)}$			—	8	64	
$t_{MERASE(1MB)}$			—	16	128	
$t_{MERASE(3MB)}$			—	32	256	

(1) Based on characterization, not tested in production.

(2) Guaranteed by design, not tested in production.

4.11. NRST pin characteristics

Table 4-20. NRST pin characteristics

Symbol	Parameter	Conditions	Min	Typ	Max	Unit
$V_{L(NRST)}^{(1)}$	NRST Input low level voltage	$V_{DD} = V_{DDA} = 2.6\text{ V}$	-0.3	—	$0.3 V_{DD}$	V
$V_{IH(NRST)}^{(1)}$	NRST Input high level voltage		$0.7 V_{DD}$	—	$V_{DD} + 0.3$	

$V_{hyst}^{(1)}$	Schmidt trigger Voltage hysteresis		—	380	—	mV
$V_{IL(NRST)}^{(1)}$	NRST Input low level voltage	$V_{DD} = V_{DDA} = 3.3\text{ V}$	-0.3	—	$0.3 V_{DD}$	V
$V_{IH(NRST)}^{(1)}$	NRST Input high level voltage		$0.7 V_{DD}$	—	$V_{DD} + 0.3$	
$V_{hyst}^{(1)}$	Schmidt trigger Voltage hysteresis		—	380	—	mV
$V_{IL(NRST)}^{(1)}$	NRST Input low level voltage	$V_{DD} = V_{DDA} = 3.6\text{ V}$	-0.3	—	$0.3 V_{DD}$	V
$V_{IH(NRST)}^{(1)}$	NRST Input high level voltage		$0.7 V_{DD}$	—	$V_{DD} + 0.3$	
$V_{hyst}^{(1)}$	Schmidt trigger Voltage hysteresis		—	420	—	mV
$R_{pu}^{(2)}$	Pull-up equivalent resistor	—	—	40	—	k Ω

- (1) Based on characterization, not tested in production.
 (2) Guaranteed by design, not tested in production.

Figure 4-2. Recommended external NRST pin circuit⁽¹⁾

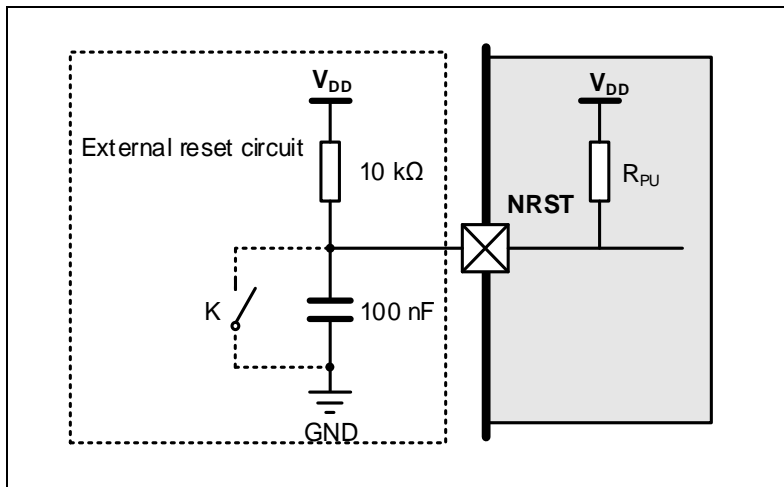

- (1) Unless the voltage on NRST pin go below $V_{IL(NRST)}$ level, the device would not generate a reliable reset.

4.12. GPIO characteristics

Table 4-21. I/O port DC characteristics⁽¹⁾⁽³⁾

Symbol	Parameter	Conditions	Min	Typ	Max	Unit
V_{IL}	Standard IO Low level input voltage	$2.6\text{ V} \leq V_{DD} = V_{DDA} \leq 3.6\text{ V}$	—	—	$0.3 V_{DD}$	V
	5V-tolerant IO Low level input voltage	$2.6\text{ V} \leq V_{DD} = V_{DDA} \leq 3.6\text{ V}$	—	—	$0.3 V_{DD}$	V
V_{IH}	Standard IO Low level input voltage	$2.6\text{ V} \leq V_{DD} = V_{DDA} \leq 3.6\text{ V}$	$0.7 V_{DD}$	—	—	V
	5V-tolerant IO Low level input voltage	$2.6\text{ V} \leq V_{DD} = V_{DDA} \leq 3.6\text{ V}$	$0.7 V_{DD}$	—	—	V
IO_Speed = 50 MHz						
V_{OL}	Low level output voltage for an IO Pin ($I_{IO} = +8\text{ mA}$)	$V_{DD} = 2.6\text{ V}$	—	0.17	—	V
		$V_{DD} = 3.3\text{ V}$	—	0.16	—	
		$V_{DD} = 3.6\text{ V}$	—	0.16	—	
	Low level output	$V_{DD} = 2.6\text{ V}$	—	0.46	—	

Symbol	Parameter	Conditions	Min	Typ	Max	Unit	
	voltage for an IO Pin (I _{IO} = +20 mA)	V _{DD} = 3.3 V	—	0.40	—		
		V _{DD} = 3.6 V	—	0.40	—		
V _{OH}	High level output voltage for an IO Pin (I _{IO} = +8 mA)	V _{DD} = 2.6 V	—	2.39	—	V	
		V _{DD} = 3.3 V	—	3.12	—		
		V _{DD} = 3.6 V	—	3.41	—		
	High level output voltage for an IO Pin (I _{IO} = +20 mA)	V _{DD} = 2.6 V	—	2.05	—		
		V _{DD} = 3.3 V	—	2.84	—		
		V _{DD} = 3.6 V	—	3.12	—		
IO_Speed = 10 MHz							
V _{OL}	High level output voltage for an IO Pin (I _{IO} = +8 mA)	V _{DD} = 2.6 V	—	0.43	—	V	
		V _{DD} = 3.3 V	—	0.35	—		
		V _{DD} = 3.6 V	—	0.34	—		
	(I _{IO} = +12 mA)	V _{DD} = 2.6 V	—	0.74	—		
	Low level output voltage for an IO Pin (I _{IO} = +15 mA)	V _{DD} = 3.3 V	—	0.75	—		
		V _{DD} = 3.6 V	—	0.69	—		
V _{OH}	High level output voltage for an IO Pin (I _{IO} = +8 mA)	V _{DD} = 2.6 V	—	2.10	—	V	
		V _{DD} = 3.3 V	—	2.90	—		
		V _{DD} = 3.6 V	—	3.22	—		
	(I _{IO} = +12 mA)	V _{DD} = 2.6 V	—	1.72	—		
	High level output voltage for an IO Pin (I _{IO} = +20 mA)	V _{DD} = 3.3 V	—	1.98	—		
		V _{DD} = 3.6 V	—	2.45	—		
IO_Speed = 2 MHz							
V _{OL}	Low level output voltage for an IO Pin (I _{IO} = +4 mA)	V _{DD} = 2.6 V	—	0.43	—	V	
		V _{DD} = 3.3 V	—	0.35	—		
		V _{DD} = 3.6 V	—	0.33	—		
V _{OH}	High level output voltage for an IO Pin (I _{IO} = +4 mA)	V _{DD} = 2.6 V	—	2.24	—	V	
		V _{DD} = 3.3 V	—	3.01	—		
		V _{DD} = 3.6 V	—	3.33	—		
R _{PU} ⁽²⁾	Internal pull-up resistor	All pins	V _{IN} = V _{SS}	30	40	50	kΩ
		PA10	—	7.5	10	13.5	
R _{PD} ⁽²⁾	Internal pull- down resistor	All pins	V _{IN} = V _{DD}	30	40	50	kΩ
		PA10	—	7.5	10	13.5	

- (1) Based on characterization, not tested in production.
- (2) Guaranteed by design, not tested in production.
- (3) All pins except PC13 / PC14 / PC15 / PI8. Since PC13 to PC15 and PI8 are supplied through the Power Switch, which can only be obtained by a small current (typical source capability: 3 mA shared between these IOs, but sink capability is same as other IO), the speed of GPIOs PC13 to PC15 and PI8 should not exceed 2 MHz when they are in output mode (maximum load: 30 pF).

Table 4-22. I/O port AC characteristics ⁽¹⁾⁽²⁾⁽⁴⁾

GPIOx_CTL->MDy[1:0] bit value ⁽³⁾	Parameter	Conditions	Max	Unit
GPIOx_CTL->MDy[1:0] = 10 (IO_Speed = 2 MHz)	T _{Rise} /T _{Fall}	2.6 ≤ V _{DD} ≤ 3.6 V, C _L = 10 pF	50.2	ns
		2.6 ≤ V _{DD} ≤ 3.6 V, C _L = 30 pF	61.2	
		2.6 ≤ V _{DD} ≤ 3.6 V, C _L = 50 pF	71.6	
GPIOx_CTL->MDy[1:0] = 01 (IO_Speed = 10 MHz)	T _{Rise} /T _{Fall}	2.6 ≤ V _{DD} ≤ 3.6 V, C _L = 10 pF	22.4	ns
		2.6 ≤ V _{DD} ≤ 3.6 V, C _L = 30 pF	29	
		2.6 ≤ V _{DD} ≤ 3.6 V, C _L = 50 pF	33	
GPIOx_CTL->MDy[1:0] = 11 (IO_Speed = 50 MHz)	T _{Rise} /T _{Fall}	2.6 ≤ V _{DD} ≤ 3.6 V, C _L = 10 pF	3.2	ns
		2.6 ≤ V _{DD} ≤ 3.6 V, C _L = 30 pF	3.8	
		2.6 ≤ V _{DD} ≤ 3.6 V, C _L = 50 pF	4.6	

- (1) Based on characterization, not tested in production.
(2) Unless otherwise specified, all test results given for T_A = 25 °C.
(3) The I/O speed is configured using the GPIOx_CTL->MDy[1:0] bits.
(4) Only for reference, Depending on user's design.

4.13. ADC characteristics

Table 4-23. ADC characteristics

Symbol	Parameter	Conditions	Min	Typ	Max	Unit
V _{DDA} ⁽¹⁾	Operating voltage	—	2.6	3.3	3.6	V
V _{IN} ⁽¹⁾	ADC input voltage range	—	0	—	V _{REF+}	V
V _{REFP} ⁽²⁾	Positive Reference Voltage	—	2.6	—	V _{DDA}	V
V _{REFN} ⁽²⁾	Negative Reference Voltage	—	—	V _{SSA}	—	V
f _{ADC} ⁽¹⁾	ADC clock	—	0.6	—	28	MHz
f _s ⁽¹⁾	Sampling rate	12-bit	0.04	—	2	MSP
		10-bit	0.05	—	2.3	
		8-bit	0.06	—	2.8	S
		6-bit	0.075	—	3.5	
V _{AIN} ⁽¹⁾	Analog input voltage	16 external; 3 internal	0	—	V _{DDA}	V
R _{AIN} ⁽²⁾	External input impedance	See Equation 1	—	—	137.5	kΩ
R _{ADC} ⁽²⁾	Input sampling switch resistance	—	—	—	0.45	kΩ
C _{ADC} ⁽²⁾	Input sampling capacitance	No pin/pad capacitance included	—	—	6.4	pF
t _{cal} ⁽²⁾	Calibration time	f _{ADC} = 28 MHz	—	3.035	—	μs
t _s ⁽²⁾	Sampling time	f _{ADC} = 28 MHz	0.05	—	8.55	μs
t _{conv} ⁽²⁾	Total conversion time (including sampling time)	12-bit	—	14	—	1/ f _{ADC}
		10-bit	—	12	—	
		8-bit	—	10	—	
		6-bit	—	8	—	
t _{su} ⁽²⁾	Startup time	—	—	—	1	μs

- (1) Based on characterization, not tested in production.

(2) Guaranteed by design, not tested in production.

Equation 1: R_{AIN} max formula
$$R_{AIN} < \frac{T_s}{f_{ADC} \cdot C_{ADC} \cdot \ln(2^{N+2})} - R_{ADC}$$

The formula above (Equation 1) is used to determine the maximum external impedance allowed for an error below 1/4 of LSB. Here N = 12 (from 12-bit resolution).

Table 4-24. ADC RAIN max for f_{ADC} = 28 MHz ⁽¹⁾⁽²⁾

T _s (cycles)	t _s (us)	R _{AIN} max (KΩ)
1.5	0.05	0.4
7.5	0.26	3.8
13.5	0.48	7.3
28.5	1.01	15.9
41.5	1.48	23.4
55.5	1.98	31.4
71.5	2.55	40.6
239.5	8.55	137.2

(1) Based on characterization, not tested in production.

(2) Guaranteed by design, not tested in production.

4.14. Temperature sensor characteristics

Table 4-25. Temperature sensor characteristics ⁽¹⁾

Symbol	Parameter	Min	Typ	Max	Unit
T _L	V _{SENSE} linearity with temperature	—	±1.5	—	°C
Avg_Slope	Average slope	—	4.1	—	mV/°C
V ₂₅	Voltage at 25 °C	—	1.45	—	V
t _{s_temp} ⁽²⁾	ADC sampling time when reading the temperature	—	17.1	—	μs

(1) Based on characterization, not tested in production.

(2) Shortest sampling time can be determined in the application by multiple iterations.

4.15. DAC characteristics

Table 4-26. DAC characteristics

Symbol	Parameter	Conditions	Min	Typ	Max	Unit
V _{DDA} ⁽¹⁾	Operating voltage	—	2.6	3.3	3.6	V
V _{REFP} ⁽²⁾	Positive Reference Voltage	—	2.6	—	V _{DDA}	V
V _{REFN} ⁽²⁾	Negative Reference Voltage	—	—	V _{SSA}	—	V
R _{LOAD} ⁽²⁾	Resistive load	Resistive load with buffer ON	5	—	—	kΩ
R _o ⁽²⁾	Impedance output	Impedance output with buffer OFF	—	—	15	kΩ
C _{LOAD} ⁽²⁾	Capacitive load	Capacitive load with buffer ON	—	—	50	pF
DAC_OUT	Lower DAC_OUT voltage	Lower DAC_OUT voltage with	0.2	—	—	V

min ⁽²⁾		buffer ON				
		Lower DAC_OUT voltage with buffer OFF	0.5	—	—	mV
DAC_OUT max ⁽²⁾	Higher DAC_OUT voltage	Higher DAC_OUT voltage with buffer ON	—	—	V _{DDA} -0.2	V
		Higher DAC_OUT voltage with buffer OFF	—	—	V _{DDA} -1LSB	V
I _{DDA} ⁽¹⁾	DAC current consumption in quiescent mode	With no load, middle code(0x800) on the input, V _{REF+} = 3.6 V	—	—	550	μA
		With no load, worst code(0xF1C) on the input, V _{REF+} = 3.6 V	—	—	600	
I _{DDVREF+} ⁽¹⁾	DAC current consumption in quiescent mode	With no load, middle code(0x800) on the input, V _{REF+} = 3.6 V	—	86	—	μA
		With no load, worst code(0xF1C) on the input, V _{REF+} = 3.6 V	—	298	—	
T _{wakeup} ⁽²⁾	Wakeup from off state	—	—	5	10	μs
Update rate ⁽²⁾	Max frequency for a correct DAC_OUT change from code i to i±1LSB	C _{LOAD} ≤ 50 pF, R _{LOAD} ≥ 5 kΩ	—	—	4	MS/s
PSRR ⁽²⁾	Power supply rejection ratio(to V _{DDA})	No R _{Load} , C _{LOAD} =50 pF	55	80	—	dB

(1) Based on characterization, not tested in production.

(2) Guaranteed by design, not tested in production.

4.16. I2C characteristics

Table 4-27. I2C characteristics ⁽¹⁾⁽²⁾

Symbol	Parameter	Conditions	Standard mode		Fast mode		Unit
			Min	Max	Min	Max	
t _{SCL(H)}	SCL clock high time	—	4.0	—	0.6	—	μs
t _{SCL(L)}	SCL clock low time	—	4.7	—	1.3	—	μs
t _{SU(SDA)}	SDA setup time	—	2	—	0.8	—	μs
t _{H(SDA)}	SDA data hold time	—	250	—	250	—	ns
t _{R(SDA/SCL)}	SDA and SCL rise time	—	—	1000	20	300	ns
t _{F(SDA/SCL)}	SDA and SCL fall time	—	4	300	4	300	ns
t _{H(STA)}	Start condition hold time	—	4.0	—	0.6	—	μs
t _{SU(STA)}	Repeated Start condition setup time	—	4.7	—	0.6	—	μs

Symbol	Parameter	Conditions	Standard mode		Fast mode		Unit
			Min	Max	Min	Max	
$t_{SU(STO)}$	Stop condition setup time	—	4.0	—	0.6	—	μs
t_{BUFF}	Stop to Start condition time (bus free)	—	4.7	—	1.3	—	μs

- (1) Guaranteed by design, not tested in production.
- (2) To ensure the standard mode I2C frequency, f_{PCLK1} must be at least 2 MHz. To ensure the fast mode I2C frequency, f_{PCLK1} must be at least 4 MHz.
- (3) The device should provide a data hold time of 300 ns at least in order to bridge the undefined region of the falling edge of SCL.

Figure 4-2. I2C bus timing diagram

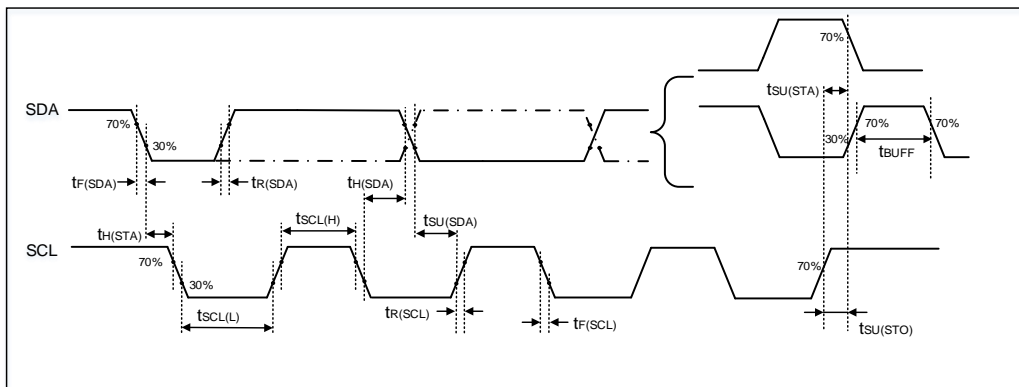

4.17. SPI characteristics

Table 4-28. Standard SPI characteristics ⁽¹⁾

Symbol	Parameter	Conditions	Min	Typ	Max	Unit
f_{SCK}	SCK clock frequency	—	—	—	30	MHz
$t_{SCK(H)}$	SCK clock high time	—	14.67	16.67	18.67	ns
$t_{SCK(L)}$	SCK clock low time	—	14.67	16.67	18.67	ns
SPI master mode						
$t_{V(MO)}$	Data output valid time	—	—	—	8	ns
$t_{SU(MI)}$	Data input setup time	—	1	—	—	ns
$t_{H(MI)}$	Data input hold time	—	0	—	—	ns
SPI slave mode						
$t_{SU(NSS)}$	NSS enable setup time	—	0	—	—	ns
$t_{H(NSS)}$	NSS enable hold time	—	1	—	—	ns
$t_{A(SO)}$	Data output access time	—	—	9	—	ns
$t_{DIS(SO)}$	Data output disable time	—	—	10	—	ns
$t_{V(SO)}$	Data output valid time	—	—	11	—	ns
$t_{SU(SI)}$	Data input setup time	—	0	—	—	ns
$t_{H(SI)}$	Data input hold time	—	2	—	—	ns

- (1) Based on characterization, not tested in production.

Figure 4-3. SPI timing diagram - master mode

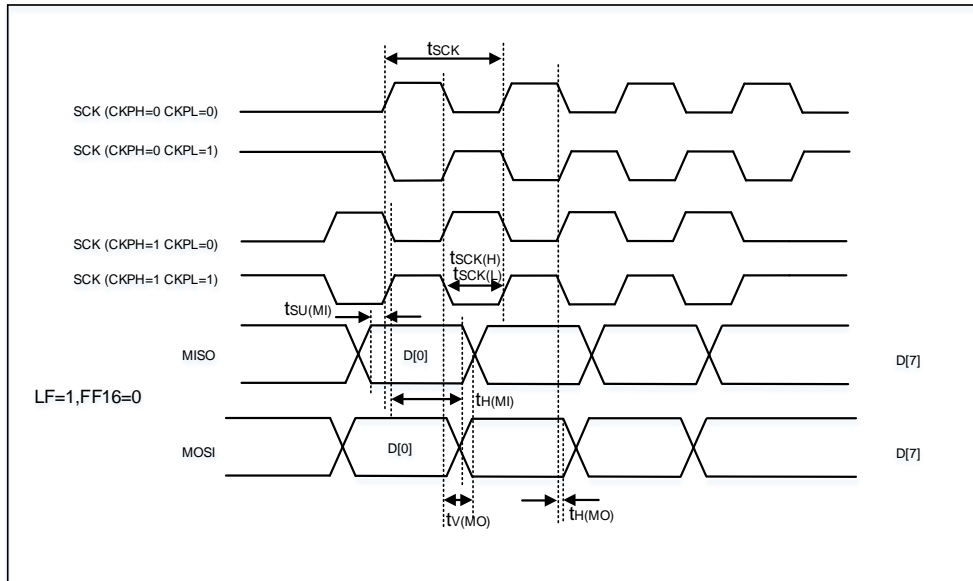
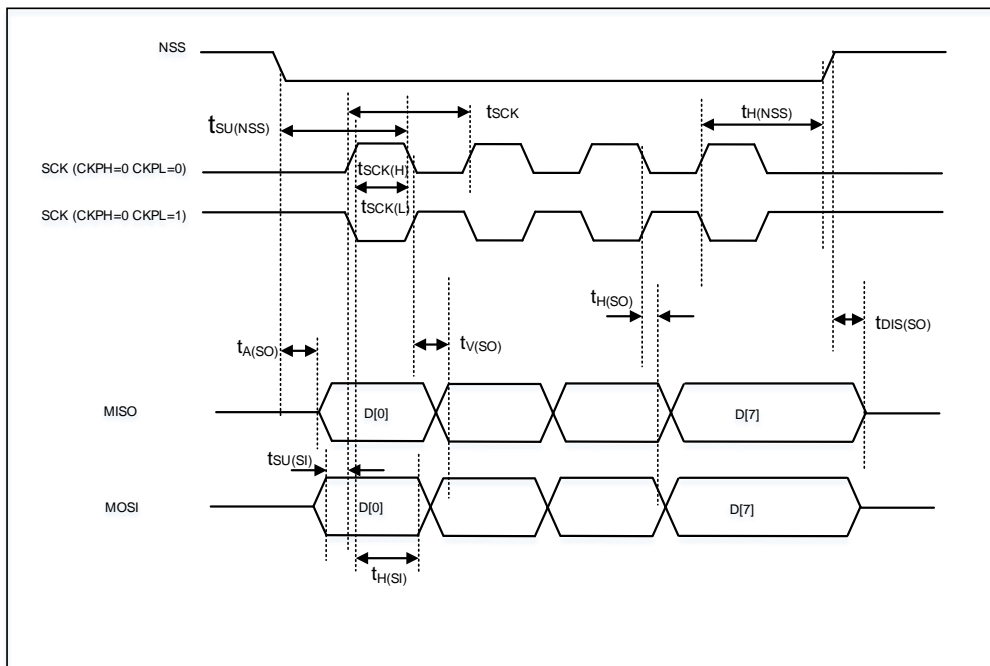

Figure 4-4. SPI timing diagram - slave mode



4.18. I2S characteristics

Table 4-29. I2S characteristics ⁽¹⁾⁽²⁾

Symbol	Parameter	Conditions	Min	Typ	Max	Unit
f_{CK}	Clock frequency	Master mode (data: 16 bits, Audio frequency = 96 kHz)	—	3.078	—	MHz
		Slave mode	—	10	—	
t_H	Clock high time	—	—	162	—	ns
t_L	Clock low time		—	163	—	ns
$t_{V(WS)}$	WS valid time	Master mode	—	2	—	ns
$t_{H(WS)}$	WS hold time	Master mode	—	2	—	ns
$t_{SU(WS)}$	WS setup time	Slave mode	0	—	—	ns
$t_{H(WS)}$	WS hold time	Slave mode	3	—	—	ns
$D_{ucy(SCK)}$	I2S slave input clock duty cycle	Slave mode	—	50	—	%
$t_{SU(SD_MR)}$	Data input setup time	Master mode	1	—	—	ns
$t_{SU(SD_SR)}$	Data input setup time	Slave mode	0	—	—	ns
$t_{H(SD_MR)}$	Data input hold time	Master receiver	0	—	—	ns
$t_{H(SD_SR)}$		Slave receiver	1	—	—	ns
$t_{V(SD_ST)}$	Data output valid time	Slave transmitter (after enable edge)	—	—	5	ns
$t_{H(SD_ST)}$	Data output hold time	Slave transmitter (after enable edge)	6	—	—	ns
$t_{V(SD_MT)}$	Data output valid time	Master transmitter (after enable edge)	—	—	5	ns
$t_{H(SD_MT)}$	Data output hold time	Master transmitter (after enable edge)	0	—	—	ns

(1) Guaranteed by design, not tested in production.

(2) Based on characterization, not tested in production.

Figure 4-5. I2S timing diagram - master mode

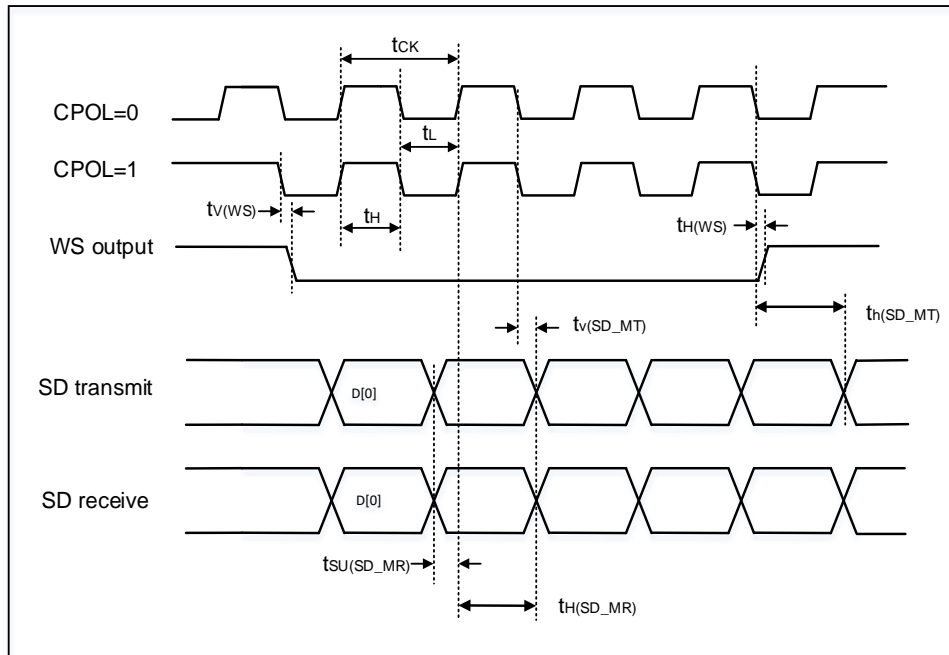
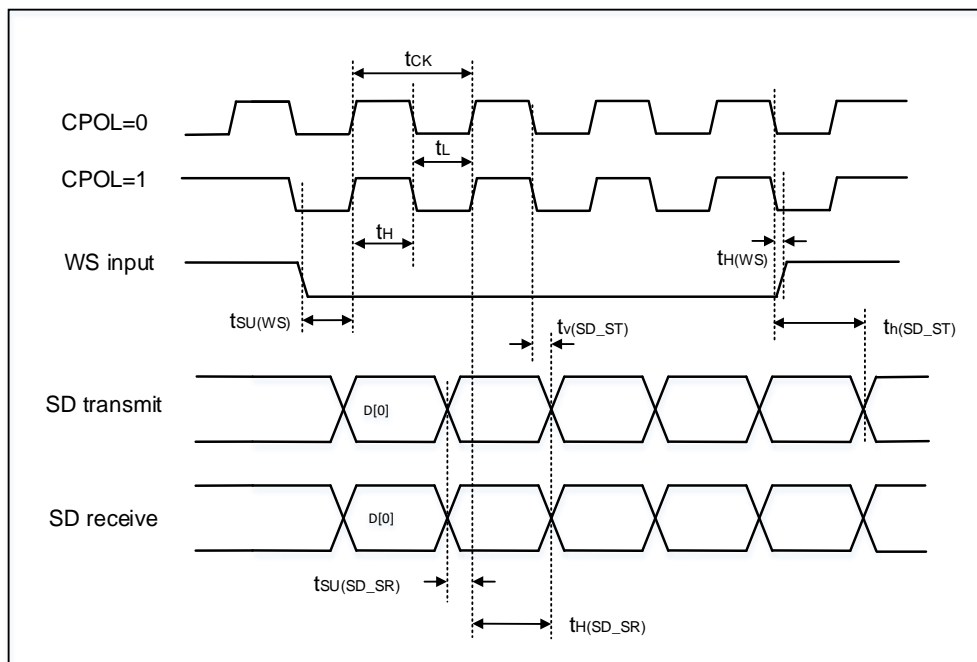

Figure 4-6. I2S timing diagram - slave mode



4.19. USART characteristics

Table 4-30. USART characteristics ⁽¹⁾

Symbol	Parameter	Conditions	Min	Typ	Max	Unit
f_{SCK}	SCK clock frequency	$f_{PCLKx} = 120 \text{ MHz}$	—	—	60	MHz
$t_{SCK(H)}$	SCK clock high time	$f_{PCLKx} = 120 \text{ MHz}$	8.3	—	—	ns
$t_{SCK(L)}$	SCK clock low time	$f_{PCLKx} = 120 \text{ MHz}$	8.3	—	—	ns

(1) Guaranteed by design, not tested in production.

4.20. SDIO characteristics

Table 4-31. SDIO characteristics ⁽¹⁾⁽²⁾

Symbol	Parameter	Conditions	Min	Typ	Max	Unit
$f_{PP}^{(3)}$	Clock frequency in data transfer mode	—	0	—	48	MHz
$t_{W(CKL)}^{(3)}$	Clock low time	$f_{pp} = 48 \text{ MHz}$	9.5	10.5	—	ns
$t_{W(CKH)}^{(3)}$	Clock high time	$f_{pp} = 48 \text{ MHz}$	9.3	10.3	—	ns
CMD, D inputs (referenced to CK) in MMC and SD HS mode						
$t_{ISU}^{(4)}$	Input setup time HS	$f_{pp} = 48 \text{ MHz}$	4	—	—	ns
$t_{IH}^{(4)}$	Input hold time HS	$f_{pp} = 48 \text{ MHz}$	3	—	—	ns
CMD, D outputs (referenced to CK) in MMC and SD HS mode						
$t_{OV}^{(3)}$	Output valid time HS	$f_{pp} = 48 \text{ MHz}$	—	—	13.8	ns
$t_{OH}^{(3)}$	Output hold time HS	$f_{pp} = 48 \text{ MHz}$	12	—	—	ns
CMD, D inputs (referenced to CK) in SD default mode						
$t_{ISUD}^{(4)}$	Input setup time SD	$f_{pp} = 24 \text{ MHz}$	3	—	—	ns
$t_{IHD}^{(4)}$	Input hold time SD	$f_{pp} = 24 \text{ MHz}$	3	—	—	ns
CMD, D outputs (referenced to CK) in SD default mode						
$t_{OVD}^{(3)}$	Output valid default time SD	$f_{pp} = 24 \text{ MHz}$	—	2.4	2.8	ns
$t_{OHD}^{(3)}$	Output hold default time SD	$f_{pp} = 24 \text{ MHz}$	2	—	—	ns

(1) CLK timing is measured at 50% of V_{DD} .

(2) Capacitive load $C_L = 30 \text{ pF}$.

(3) Based on characterization, not tested in production.

(4) Guaranteed by design, not tested in production.

4.21. CAN characteristics

Refer to [Table 4-21. I/O port DC characteristics](#) for more details on the input/output alternate function characteristics (CAN TX and CAN RX).

4.22. USBFS characteristics

Table 4-32. USBFS start up time

Symbol	Parameter	Max	Unit
$t_{STARTUP}^{(1)}$	USBFS startup time	1	μs

(1) Guaranteed by design, not tested in production.

Table 4-33. USBFS DC electrical characteristics

Symbol	Parameter	Conditions	Min	Typ	Max	Unit	
Input levels ⁽¹⁾	V_{DD}	USBFS operating voltage	—	3	—	3.6	V
	V_{DI}	Differential input sensitivity	—	0.2	—	—	
	V_{CM}	Differential common mode range	Includes V_{DI} range	0.8	—	2.5	
	V_{SE}	Single ended receiver threshold	—	1.3	—	2.0	
Output levels ⁽²⁾	V_{OL}	Static output level low	R_L of 1.0 k Ω to 3.6 V	—	0.06	0.3	V
	V_{OH}	Static output level high	R_L of 15 k Ω to V_{SS}	2.8	3.3	3.6	
$R_{PD}^{(2)}$	PA11, PA12(USBFS_DM/DP) PB14, PB15(USBHS_DM/DP)	$V_{IN} = V_{DD}$	17	21	25	k Ω	
	PA9(USBFS_VBUS) PB13(USBHS_VBUS)		0.72	0.9	1.1		
$R_{PU}^{(2)}$	PA11, PA12(USBFS_DM/DP) PB14, PB15(USBHS_DM/DP)	$V_{IN} = V_{SS}$	1.2	1.5	1.8		
	PA9(USBFS_VBUS) PB13(USBHS_VBUS)		0.24	0.3	0.33		

(1) Guaranteed by design, not tested in production.

(2) Based on characterization, not tested in production.

Table 4-34. USBFS full speed-electrical characteristics ⁽¹⁾

Symbol	Parameter	Conditions	Min	Typ	Max	Unit
t_R	Rise time	$C_L = 50$ pF	4	—	20	ns
t_F	Fall time	$C_L = 50$ pF	4	—	20	ns
t_{RFM}	Rise/ fall time matching	t_R / t_F	90	—	110	%
V_{CRS}	Output signal crossover voltage	—	1.3	—	2.0	V

(1) Guaranteed by design, not tested in production.

Figure 4-7. USBFS timings: definition of data signal rise and fall time

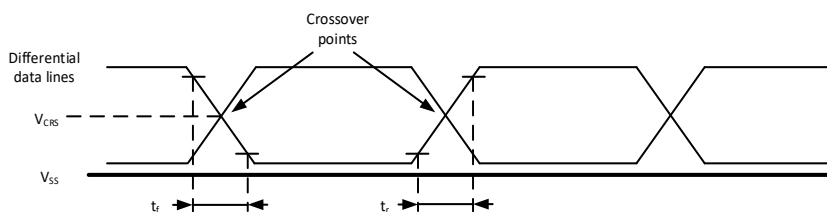

4.23. EXMC characteristics

Table 4-35. Asynchronous non-multiplexed SRAM/PSRAM/NOR read timings ⁽¹⁾⁽²⁾⁽³⁾

Symbol	Parameter	Min	Max	Unit
$t_{w(NE)}$	EXMC_NE low time	40.5	42.5	ns
$t_{v(NO_NE)}$	EXMC_NEx low to EXMC_NOE low	0	—	ns
$t_{w(NO)}$	EXMC_NOE low time	40.5	42.5	ns
$t_{h(NE_NO)}$	EXMC_NOE high to EXMC_NE high hold time	0	—	ns
$t_{v(A_NE)}$	EXMC_NEx low to EXMC_A valid	0	—	ns
$t_{v(BL_NE)}$	EXMC_NEx low to EXMC_BL valid	0	—	ns
$t_{su(DATA_NE)}$	Data to EXMC_NEx high setup time	32.2	—	ns
$t_{su(DATA_NO)}$	Data to EXMC_NOEx high setup time	32.2	—	ns
$t_{h(DATA_NO)}$	Data hold time after EXMC_NOE high	0	—	ns
$t_{h(DATA_NE)}$	Data hold time after EXMC_NEx high	0	—	ns
$t_{v(NADV_NE)}$	EXMC_NEx low to EXMC_NADV low	0	—	ns
$t_{w(NADV)}$	EXMC_NADV low time	7.3	9.3	ns

(1) $C_L = 30$ pF.

(2) Guaranteed by design, not tested in production.

(3) Based on configure: $f_{HCLK} = 120$ MHz, AddressSetupTime = 0, AddressHoldTime = 1, DataSetupTime = 1.

Table 4-36. Asynchronous non-multiplexed SRAM/PSRAM/NOR write timings ⁽¹⁾⁽²⁾⁽³⁾

Symbol	Parameter	Min	Max	Unit
$t_{w(NE)}$	EXMC_NE low time	23.9	25.9	ns
$t_{v(NWE_NE)}$	EXMC_NEx low to EXMC_NWE low	7.3	—	ns
$t_{w(NWE)}$	EXMC_NWE low time	7.3	9.3	ns
$t_{h(NE_NWE)}$	EXMC_NWE high to EXMC_NE high hold time	7.3	9.3	ns
$t_{v(A_NE)}$	EXMC_NEx low to EXMC_A valid	0	—	ns
$t_{v(NADV_NE)}$	EXMC_NEx low to EXMC_NADV low	0	—	ns
$t_{w(NADV)}$	EXMC_NADV low time	7.3	9.3	ns
$t_{h(AD_NADV)}$	EXMC_AD(address) valid hold time after EXMC_NADV high	15.6	—	ns
$t_{h(A_NWE)}$	Address hold time after EXMC_NWE high	7.3	—	ns
$t_{h(BL_NWE)}$	EXMC_BL hold time after EXMC_NWE high	7.3	—	ns
$t_{v(BL_NE)}$	EXMC_NEx low to EXMC_BL valid	0	—	ns
$t_{v(DATA_NADV)}$	EXMC_NADV high to DATA valid	0	—	ns
$t_{h(DATA_NWE)}$	Data hold time after EXMC_NWE high	7.3	—	ns

(1) $C_L = 30$ pF.

(2) Guaranteed by design, not tested in production.

(3) Based on configure: $f_{HCLK} = 120$ MHz, AddressSetupTime = 0, AddressHoldTime = 1, DataSetupTime = 1.

Table 4-37. Asynchronous multiplexed PSRAM/NOR read timings ⁽¹⁾⁽²⁾⁽³⁾

Symbol	Parameter	Min	Max	Unit
$t_{w(NE)}$	EXMC_NE low time	57.1	59.1	ns
$t_{v(NOE_NE)}$	EXMC_NEx low to EXMC_NOE low	23.9	—	ns
$t_{w(NOE)}$	EXMC_NOE low time	32.2	34.2	ns
$t_{h(NE_NOE)}$	EXMC_NOE high to EXMC_NE high hold time	0	—	ns
$t_{v(A_NE)}$	EXMC_NEx low to EXMC_A valid	0	—	ns
$t_{v(A_NOE)}$	Address hold time after EXMC_NOE high	0	—	ns
$t_{v(BL_NE)}$	EXMC_NEx low to EXMC_BL valid	0	—	ns
$t_{h(BL_NOE)}$	EXMC_BL hold time after EXMC_NOE high	0	—	ns
$t_{su(DATA_NE)}$	Data to EXMC_NEx high setup time	33.2	—	ns
$t_{su(DATA_NOE)}$	Data to EXMC_NOEx high setup time	33.2	—	ns
$t_{h(DATA_NOE)}$	Data hold time after EXMC_NOE high	0	—	ns
$t_{h(DATA_NE)}$	Data hold time after EXMC_NEx high	0	—	ns
$t_{v(NADV_NE)}$	EXMC_NEx low to EXMC_NADV low	0	—	ns
$t_{w(NADV)}$	EXMC_NADV low time	7.3	9.3	ns
$T_{h(AD_NADV)}$	EXMC_AD(address) valid hold time after EXMC_NADV high	7.3	9.3	ns

(1) $C_L = 30$ pF.

(2) Guaranteed by design, not tested in production.

(3) Based on configure: $f_{HCLK} = 120$ MHz, AddressSetupTime = 0, AddressHoldTime = 1, DataSetupTime = 1.

Table 4-38. Asynchronous multiplexed PSRAM/NOR write timings ⁽¹⁾⁽²⁾⁽³⁾

Symbol	Parameter	Min	Max	Unit
$t_{w(NE)}$	EXMC_NE low time	40.5	42.5	ns
$t_{v(NWE_NE)}$	EXMC_NEx low to EXMC_NWE low	7.3	—	ns
$t_{w(NWE)}$	EXMC_NWE low time	23.9	25.9	ns
$t_{h(NE_NWE)}$	EXMC_NWE high to EXMC_NE high hold time	7.3	—	ns
$t_{v(A_NE)}$	EXMC_NEx low to EXMC_A valid	0	—	ns
$t_{v(NADV_NE)}$	EXMC_NEx low to EXMC_NADV low	0	—	ns
$t_{w(NADV)}$	EXMC_NADV low time	7.3	9.3	ns
$t_{h(AD_NADV)}$	EXMC_AD(address) valid hold time after EXMC_NADV high	7.3	—	ns
$t_{h(A_NWE)}$	Address hold time after EXMC_NWE high	7.3	—	ns
$t_{h(BL_NWE)}$	EXMC_BL hold time after EXMC_NWE high	7.3	—	ns
$t_{v(BL_NE)}$	EXMC_NEx low to EXMC_BL valid	0	—	ns
$t_{v(DATA_NADV)}$	EXMC_NADV high to DATA valid	7.3	—	ns
$t_{h(DATA_NWE)}$	Data hold time after EXMC_NWE high	7.3	—	ns

(1) $C_L = 30$ pF.

(2) Guaranteed by design, not tested in production.

(3) Based on configure: $f_{HCLK} = 120$ MHz, AddressSetupTime = 0, AddressHoldTime = 1, DataSetupTime = 1.

Table 4-39. Synchronous multiplexed PSRAM/NOR read timings ⁽¹⁾⁽²⁾⁽³⁾

Symbol	Parameter	Min	Max	Unit
$t_{w(CLK)}$	EXMC_CLK period	33.2	—	ns
$t_{d(CLKL-NExL)}$	EXMC_CLK low to EXMC_NEx low	0	—	ns
$t_{d(CLKH-NExH)}$	EXMC_CLK high to EXMC_NEx high	15.6	—	ns
$t_{d(CLKL-NADV L)}$	EXMC_CLK low to EXMC_NADV low	0	—	ns
$t_{d(CLKL-NADV H)}$	EXMC_CLK low to EXMC_NADV high	0	—	ns
$t_{d(CLKL-AV)}$	EXMC_CLK low to EXMC_Ax valid	0	—	ns
$t_{d(CLKH-AIV)}$	EXMC_CLK high to EXMC_Ax invalid	15.6	—	ns
$t_{d(CLKL-NOEL)}$	EXMC_CLK low to EXMC_NOE low	0	—	ns
$t_{d(CLKH-NOEH)}$	EXMC_CLK high to EXMC_NOE high	15.6	—	ns
$t_{d(CLKL-ADV)}$	EXMC_CLK low to EXMC_AD valid	0	—	ns
$t_{d(CLKL-ADIV)}$	EXMC_CLK low to EXMC_AD invalid	0	—	ns

(1) $C_L = 30$ pF.

(2) Guaranteed by design, not tested in production.

(3) Based on configure: $f_{HCLK} = 120$ MHz, BurstAccessMode = Enable; Memory Type = PSRAM; WriteBurst = Enable; CLKDivision = 3(EXMC_CLK is 4 divided by HCLK); Data Latency = 1.

Table 4-40. Synchronous multiplexed PSRAM write timings ⁽¹⁾⁽²⁾⁽³⁾

Symbol	Parameter	Min	Max	Unit
$t_{w(CLK)}$	EXMC_CLK period	33.2	—	ns
$t_{d(CLKL-NExL)}$	EXMC_CLK low to EXMC_NEx low	0	—	ns
$t_{d(CLKH-NExH)}$	EXMC_CLK high to EXMC_NEx high	15.6	—	ns
$t_{d(CLKL-NADV L)}$	EXMC_CLK low to EXMC_NADV low	0	—	ns
$t_{d(CLKL-NADV H)}$	EXMC_CLK low to EXMC_NADV high	0	—	ns
$t_{d(CLKL-AV)}$	EXMC_CLK low to EXMC_Ax valid	0	—	ns
$t_{d(CLKH-AIV)}$	EXMC_CLK high to EXMC_Ax invalid	15.6	—	ns
$t_{d(CLKL-NWEL)}$	EXMC_CLK low to EXMC_NWE low	0	—	ns
$t_{d(CLKH-NWEH)}$	EXMC_CLK high to EXMC_NWE high	15.6	—	ns
$t_{d(CLKL-ADIV)}$	EXMC_CLK low to EXMC_AD invalid	0	—	ns
$t_{d(CLKL-DATA)}$	EXMC_A/D valid data after EXMC_CLK low	0	—	ns
$t_{h(CLKL-NBLH)}$	EXMC_CLK low to EXMC_NBL high	0	—	ns

(1) $C_L = 30$ pF.

(2) Guaranteed by design, not tested in production.

(3) Based on configure: $f_{HCLK} = 120$ MHz, BurstAccessMode = Enable; MemoryType = PSRAM; WriteBurst = Enable; CLKDivision = 3 (EXMC_CLK is 4 divided by HCLK); DataLatency = 1.

Table 4-41. Synchronous non-multiplexed PSRAM/NOR read timings ⁽¹⁾⁽²⁾⁽³⁾

Symbol	Parameter	Min	Max	Unit
$t_{w(CLK)}$	EXMC_CLK period	33.2	—	ns
$t_{d(CLKL-NExL)}$	EXMC_CLK low to EXMC_NEx low	0	—	ns
$t_{d(CLKH-NExH)}$	EXMC_CLK high to EXMC_NEx high	15.6	—	ns
$t_{d(CLKL-NADV L)}$	EXMC_CLK low to EXMC_NADV low	0	—	ns
$t_{d(CLKL-NADV H)}$	EXMC_CLK low to EXMC_NADV high	0	—	ns
$t_{d(CLKL-AV)}$	EXMC_CLK low to EXMC_Ax valid	0	—	ns
$t_{d(CLKH-AIV)}$	EXMC_CLK high to EXMC_Ax invalid	15.6	—	ns
$t_{d(CLKL-NOEL)}$	EXMC_CLK low to EXMC_NOE low	0	—	ns
$t_{d(CLKH-NOEH)}$	EXMC_CLK high to EXMC_NOE high	15.6	—	ns

(1) $C_L = 30$ pF.

(2) Guaranteed by design, not tested in production.

(3) Based on configure: HCLK = 120 MHz, BurstAccessMode = Enable; MemoryType = PSRAM; WriteBurst = Enable; CLKDivision = 3 (EXMC_CLK is 4 divided by HCLK); DataLatency = 1.

Table 4-42. Synchronous non-multiplexed PSRAM write timings ⁽¹⁾⁽²⁾⁽³⁾

Symbol	Parameter	Min	Max	Unit
$t_{w(CLK)}$	EXMC_CLK period	33.2	—	ns
$t_{d(CLKL-NExL)}$	EXMC_CLK low to EXMC_NEx low	0	—	ns
$t_{d(CLKH-NExH)}$	EXMC_CLK high to EXMC_NEx high	15.6	—	ns
$t_{d(CLKL-NADV L)}$	EXMC_CLK low to EXMC_NADV low	0	—	ns
$t_{d(CLKL-NADV H)}$	EXMC_CLK low to EXMC_NADV high	0	—	ns
$t_{d(CLKL-AV)}$	EXMC_CLK low to EXMC_Ax valid	0	—	ns
$t_{d(CLKH-AIV)}$	EXMC_CLK high to EXMC_Ax invalid	15.6	—	ns
$t_{d(CLKL-NWEL)}$	EXMC_CLK low to EXMC_NWE low	0	—	ns
$t_{d(CLKH-NWEH)}$	EXMC_CLK high to EXMC_NWE high	15.6	—	ns
$t_{d(CLKL-DATA)}$	EXMC_A/D valid data after EXMC_CLK low	0	—	ns
$t_{h(CLKL-NBLH)}$	EXMC_CLK low to EXMC_NBL high	0	—	ns

(1) $C_L = 30$ pF.

(2) Guaranteed by design, not tested in production.

(3) Based on configure: HCLK = 120 MHz, BurstAccessMode = Enable; MemoryType = PSRAM; WriteBurst = Enable; CLKDivision = 3(EXMC_CLK is 4 divided by HCLK); DataLatency = 1.

4.24. TIMER characteristics

Table 4-43. TIMER characteristics ⁽¹⁾

Symbol	Parameter	Conditions	Min	Max	Unit
t_{res}	Timer resolution time	—	1	—	$t_{TIMERxCLK}$
		$f_{TIMERxCLK} = 120$ MHz	8.4	—	ns
f_{EXT}	Timer external clock frequency	—	0	$f_{TIMERxCLK}/2$	MHz
		$f_{TIMERxCLK} = 200$ MHz	0	60	MHz
RES	Timer resolution	—	—	16	bit
$t_{COUNTER}$	16-bit counter clock period	—	1	65536	$t_{TIMERxCLK}$

	when internal clock is selected	$f_{\text{TIMERxCLK}} = 120 \text{ MHz}$	0.0084	546	μs
$t_{\text{MAX_COUNT}}$	Maximum possible count	—	—	65536x65536	$t_{\text{TIMERxCLK}}$
		$f_{\text{TIMERxCLK}} = 120 \text{ MHz}$	—	35.7	s

(1) Guaranteed by design, not tested in production.

4.25. DCI characteristics

Table 4-44. DCI characteristics ⁽¹⁾

Symbol	Parameter	Min	Max	Unit
Frequency ratio	DCI_PIXCLK /fHCLK	—	0.4	
DCI_PIXCLK	Pixel clock input	—	48	MHz
D _{Pixel}	Pixel clock input duty cycle	30	70	%
$t_{\text{su}}(\text{DATA})$	Data input setup time	2.5	—	ns
$t_{\text{h}}(\text{DATA})$	Data output valid time	1	—	ns
$t_{\text{su}}(\text{HSYNC})$	DCI_HS input setup time	2	—	ns
$t_{\text{su}}(\text{VSYNC})$	DCI_VS input setup time	2	—	ns
$t_{\text{h}}(\text{HSYNC})$	DCI_HS input hold time	0.5	—	ns
$t_{\text{h}}(\text{VSYNC})$	DCI_VS input hold time	0.5	—	ns

(1) Guaranteed by design, not tested in production.

4.26. WDGT characteristics

Table 4-45. FWDGT min/max timeout period at 40 kHz (IRC40K) ⁽¹⁾

Prescaler divider	PSC[2:0] bits	Min timeout RLD[11:0] = 0x000	Max timeout RLD[11:0] = 0xFFFF	Unit
1/4	000	0.025	409.525	ms
1/8	001	0.025	819.025	
1/16	010	0.025	1638.025	
1/32	011	0.025	3276.025	
1/64	100	0.025	6552.025	
1/128	101	0.025	13104.025	
1/256	110 or 111	0.025	26208.025	

(1) Guaranteed by design, not tested in production.

Table 4-46. WWDGT min-max timeout value at 60 MHz (f_{PCLK1}) ⁽¹⁾

Prescaler divider	PSC[1:0]	Min timeout value CNT[6:0] = 0x40	Unit	Max timeout value CNT[6:0] = 0x7F	Unit
1/1	00	68.2	μs	4.3	ms
1/2	01	136.4		8.6	
1/4	10	272.8		17.2	
1/8	11	545.6		34.4	

(1) Guaranteed by design, not tested in production.

4.27. Parameter conditions

Unless otherwise specified, all values given for $V_{DD} = V_{DDA} = 3.3\text{ V}$, $T_A = 25\text{ }^\circ\text{C}$.

5. Package information

5.1. LQFP176 package outline dimensions

Figure 5-1. LQFP176 package outline

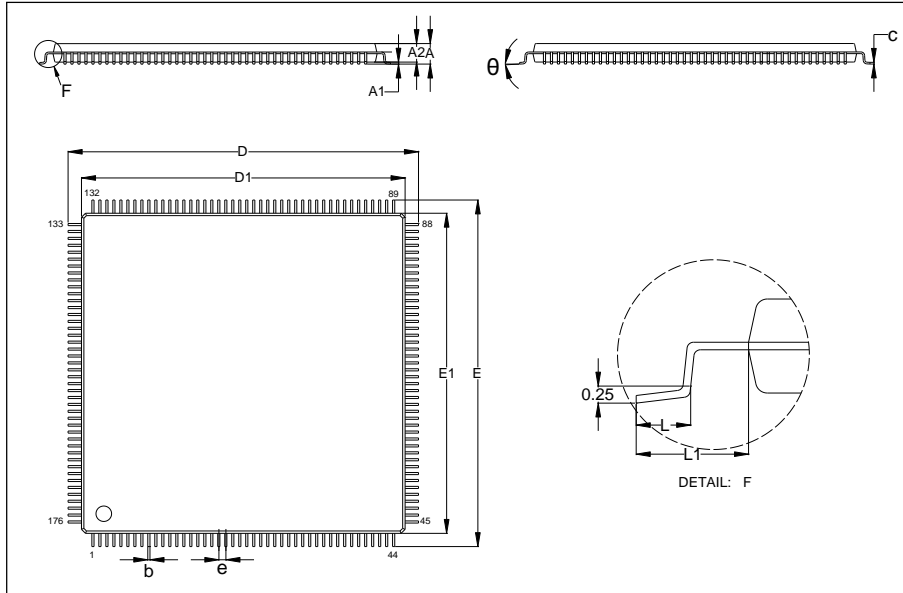
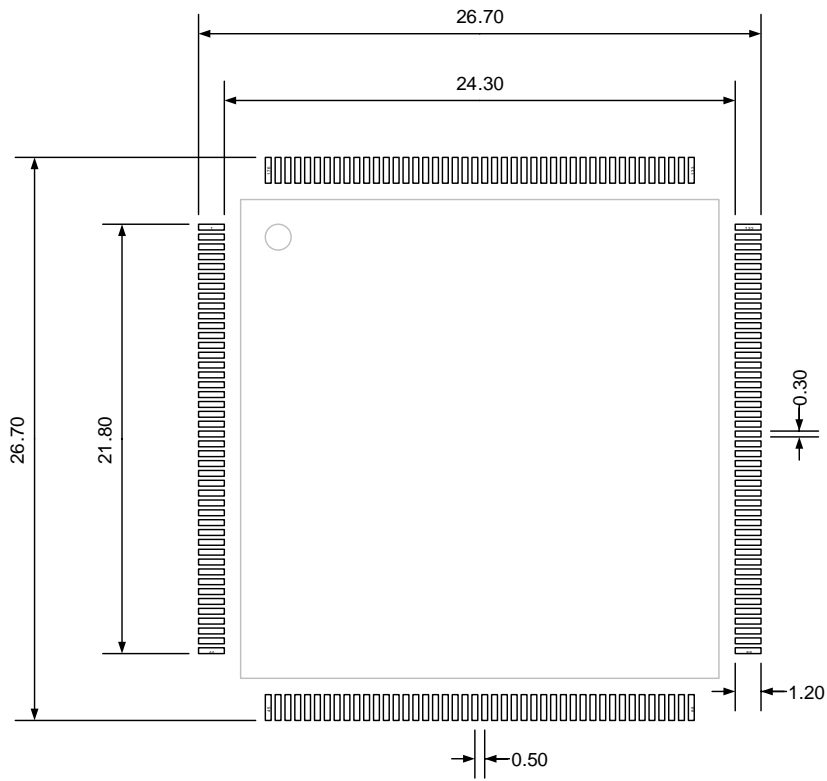

Table 5-1. LQFP176 package dimensions

Symbol	Min	Typ	Max
A	—	—	1.60
A1	0.05	—	0.15
A2	1.35	1.40	1.45
b	0.17	—	0.27
c	0.09	—	0.20
D	—	26.00	—
D1	—	24.00	—
E	—	26.00	—
E1	—	24.00	—
e	—	0.50	—
L	0.45	0.60	0.75
L1	—	1.00	—
θ	0°	3.5°	7°

(Original dimensions are in millimeters)

Figure 5-2. LQFP176 recommended footprint



(Original dimensions are in millimeters)

5.2. LQFP144 package outline dimensions

Figure 5-3. LQFP144 package outline

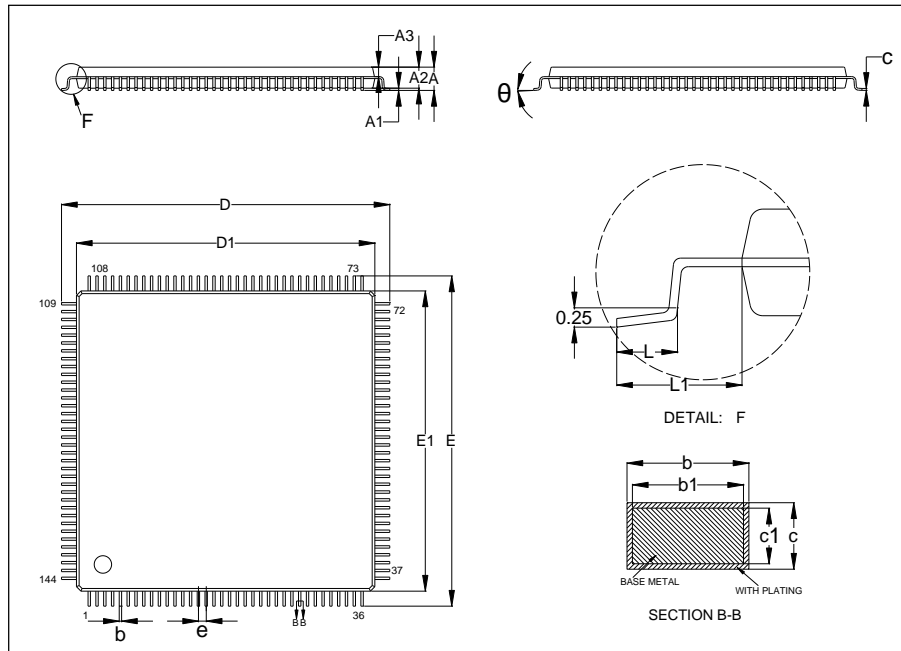
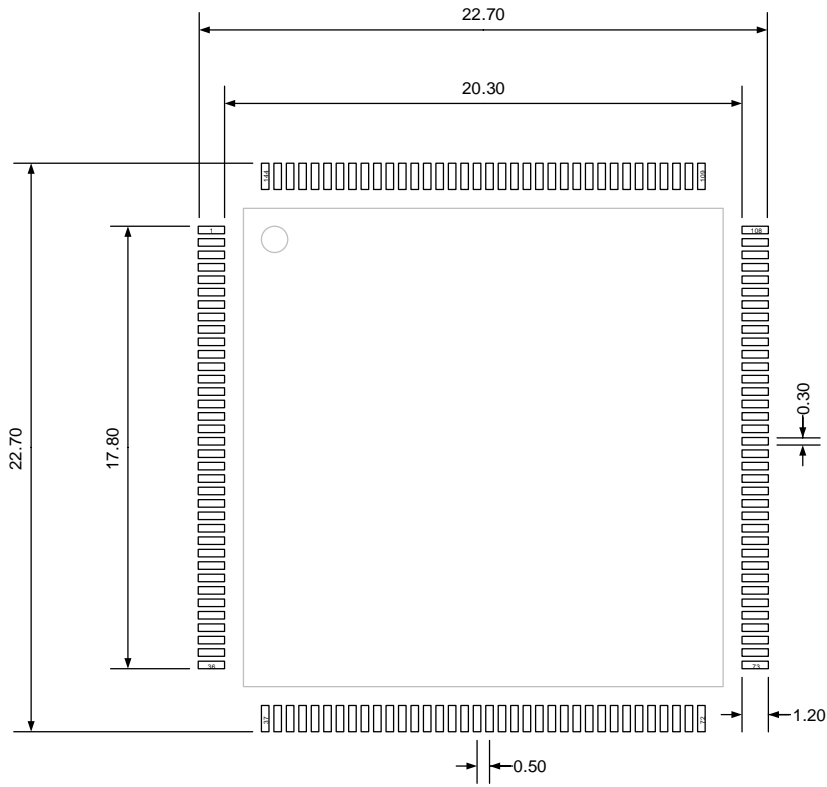

Table 5-2. LQFP144 package dimensions

Symbol	Min	Typ	Max
A	—	—	1.60
A1	0.05	—	0.15
A2	1.35	1.40	1.45
A3	0.59	0.64	0.69
b	0.18	—	0.26
b1	0.17	0.20	0.23
c	0.13	—	0.17
c1	0.12	0.13	0.14
D	21.80	22.00	22.20
D1	19.90	20.00	20.10
E	21.80	22.00	22.20
E1	19.90	20.00	20.10
e	—	0.50	—
L	0.45	—	0.75
L1	—	1.00	—
θ	0°	—	7°

(Original dimensions are in millimeters)

Figure 5-4. LQFP144 recommended footprint



(Original dimensions are in millimeters)

5.3. LQFP100 package outline dimensions

Figure 5-5. LQFP100 package outline

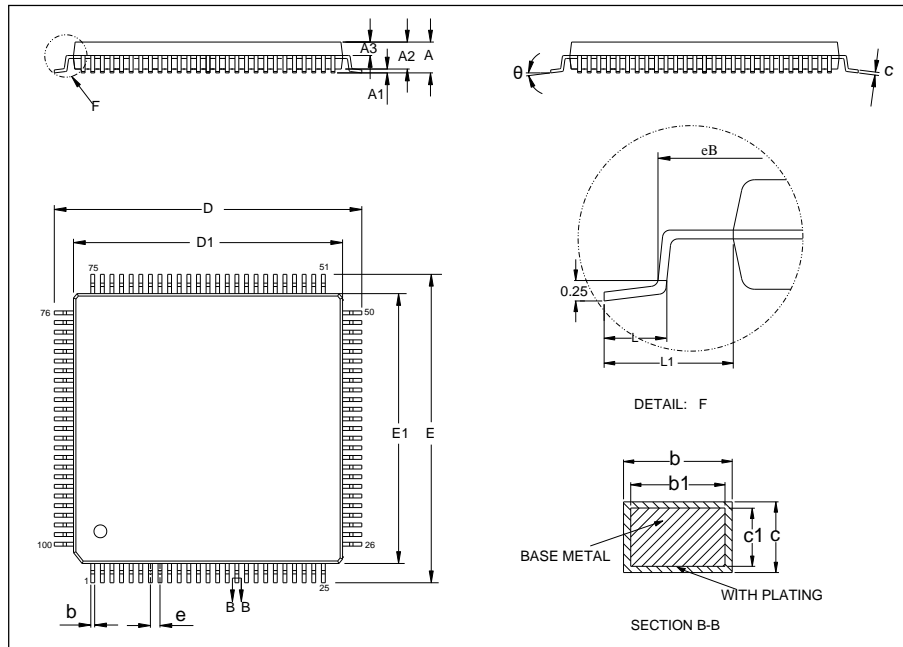
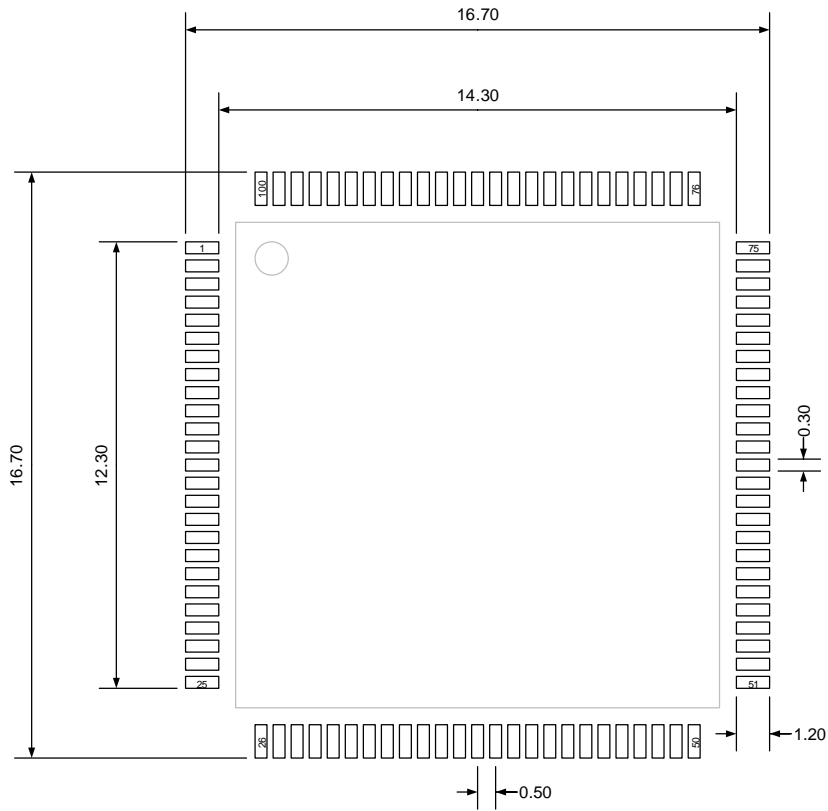

Table 5-3. LQFP100 package dimensions

Symbol	Min	Typ	Max
A	—	—	1.60
A1	0.05	—	0.15
A2	1.35	1.40	1.45
A3	0.59	0.64	0.69
b	0.18	—	0.26
b1	0.17	0.20	0.23
c	0.13	—	0.17
c1	0.12	0.13	0.14
D	15.80	16.00	16.20
D1	13.90	14.00	14.10
E	15.80	16.00	16.20
E1	13.90	14.00	14.10
e	—	0.50	—
eB	15.05	—	15.35
L	0.45	—	0.75
L1	—	1.00	—
θ	0°	—	7°

(Original dimensions are in millimeters)

Figure 5-6. LQFP100 recommended footprint



(Original dimensions are in millimeters)

5.4. LQFP64 package outline dimensions

Figure 5-7. LQFP64 package outline

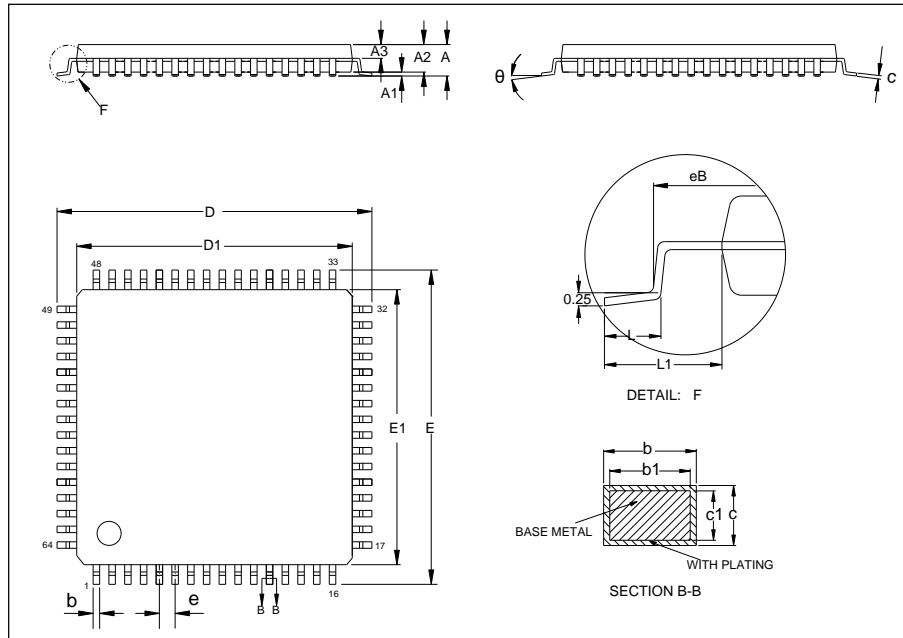
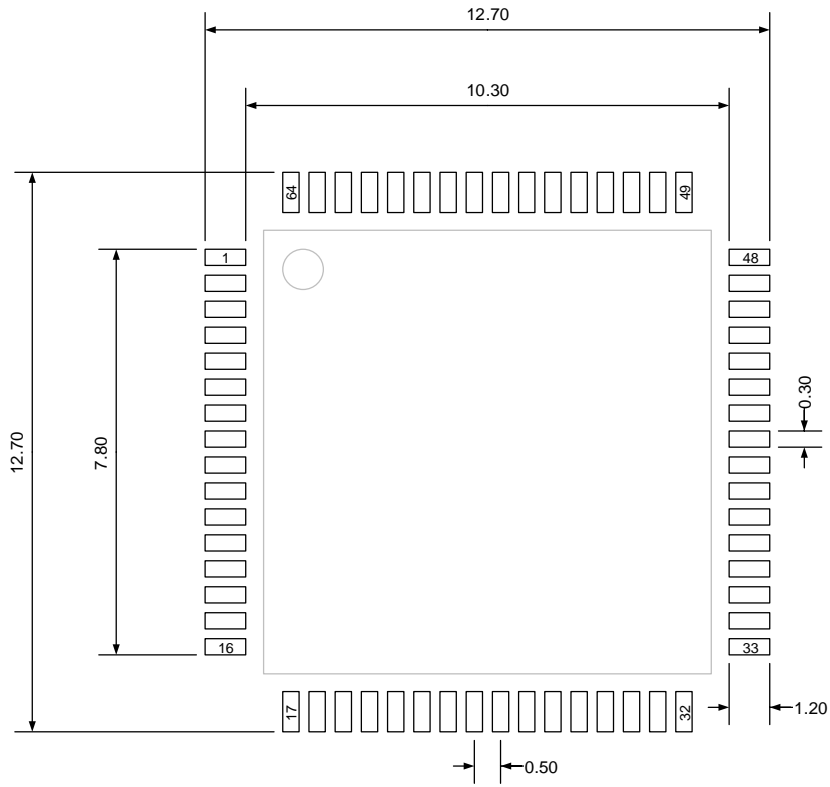

Table 5-4. LQFP64 package dimensions

Symbol	Min	Typ	Max
A	—	—	1.60
A1	0.05	—	0.15
A2	1.35	1.40	1.45
A3	0.59	0.64	0.69
b	0.18	—	0.26
b1	0.17	0.20	0.23
c	0.13	—	0.17
c1	0.12	0.13	0.14
D	11.80	12.00	12.20
D1	9.90	10.00	10.10
E	11.80	12.00	12.20
E1	9.90	10.00	10.10
e	—	0.50	—
eB	11.25	—	11.45
L	0.45	—	0.75
L1	—	1.00	—
θ	0°	—	7°

(Original dimensions are in millimeters)

Figure 5-8. LQFP64 recommended footprint



(Original dimensions are in millimeters)

5.5. Thermal characteristics

Thermal resistance is used to characterize the thermal performance of the package device, which is represented by the Greek letter “ θ ”. For semiconductor devices, thermal resistance represents the steady-state temperature rise of the chip junction due to the heat dissipated on the chip surface.

θ_{JA} : Thermal resistance, junction-to-ambient.

θ_{JB} : Thermal resistance, junction-to-board.

θ_{JC} : Thermal resistance, junction-to-case.

Ψ_{JB} : Thermal characterization parameter, junction-to-board.

Ψ_{JT} : Thermal characterization parameter, junction-to-top center.

$$\theta_{JA}=(T_J-T_A)/P_D \quad (5-1)$$

$$\theta_{JB}=(T_J-T_B)/P_D \quad (5-2)$$

$$\theta_{JC}=(T_J-T_C)/P_D \quad (5-3)$$

Where, T_J = Junction temperature.

T_A = Ambient temperature

T_B = Board temperature

T_C = Case temperature which is monitoring on package surface

P_D = Total power dissipation

θ_{JA} represents the resistance of the heat flows from the heating junction to ambient air. It is an indicator of package heat dissipation capability. Lower θ_{JA} can be considerate as better overall thermal performance. θ_{JA} is generally used to estimate junction temperature.

θ_{JB} is used to measure the heat flow resistance between the chip surface and the PCB board.

θ_{JC} represents the thermal resistance between the chip surface and the package top case. θ_{JC} is mainly used to estimate the heat dissipation of the system (using heat sink or other heat dissipation methods outside the device package).

Table 5-5. Package thermal characteristics⁽¹⁾

Symbol	Condition	Package	Value	Unit
θ_{JA}	Natural convection, 2S2P PCB	LQFP176	—	°C/W
		LQFP144	48.76	
		LQFP100	57.42	
		LQFP64	61.80	
θ_{JB}	Cold plate, 2S2P PCB	LQFP176	—	°C/W
		LQFP144	35.00	
		LQFP100	31.68	

Symbol	Condition	Package	Value	Unit
		LQFP64	42.83	
θ_{JC}	Cold plate, 2S2P PCB	LQFP176	—	°C/W
		LQFP144	12.03	
		LQFP100	13.85	
		LQFP64	21.98	
Ψ_{JB}	Natural convection, 2S2P PCB	LQFP176	—	°C/W
		LQFP144	35.32	
		LQFP100	41.28	
		LQFP64	43.05	
Ψ_{JT}	Natural convection, 2S2P PCB	LQFP176	—	°C/W
		LQFP144	1.86	
		LQFP100	0.75	
		LQFP64	1.58	

(1) Thermal characteristics are based on simulation, and meet JEDEC specification.

6. Ordering information

Table 6-1. Part ordering code for GD32F207xx devices

Ordering code	Flash (KB)	Package	Package type	Temperature operating range
GD32F207IKT6	3072	LQFP176	Green	Industrial -40°C to +85°C
GD32F207IGT6	1024	LQFP176	Green	Industrial -40°C to +85°C
GD32F207IET6	512	LQFP176	Green	Industrial -40°C to +85°C
GD32F207ZKT6	3072	LQFP144	Green	Industrial -40°C to +85°C
GD32F207ZGT6	1024	LQFP144	Green	Industrial -40°C to +85°C
GD32F207ZET6	512	LQFP144	Green	Industrial -40°C to +85°C
GD32F207ZCT6	256	LQFP144	Green	Industrial -40°C to +85°C
GD32F207VKT6	3072	LQFP100	Green	Industrial -40°C to +85°C
GD32F207VGT6	1024	LQFP100	Green	Industrial -40°C to +85°C
GD32F207VET6	512	LQFP100	Green	Industrial -40°C to +85°C
GD32F207VCT6	256	LQFP100	Green	Industrial -40°C to +85°C
GD32F207RKT6	3072	LQFP64	Green	Industrial -40°C to +85°C
GD32F207RGT6	1024	LQFP64	Green	Industrial -40°C to +85°C
GD32F207RET6	512	LQFP64	Green	Industrial -40°C to +85°C
GD32F207RCT6	256	LQFP64	Green	Industrial -40°C to +85°C

7. Revision history

Table 7-1. Revision history

Revision No.	Description	Date
1.0	Initial Release	Jul. 10, 2015
2.0	Adapt To New Name Convention	Jan. 24, 2018
2.1	Change pin definitions	Dec. 7, 2018
2.2	Modify the clock tree	Nov. 30, 2019
2.3	1.Modify the HXTAL frequency range of the clock tree to 4-32MHz. 2.The ADC2 mapping function corresponding to PF3, PF4 and PF5 pins is modified to multiplexing function.	Mar.13, 2020
2.4	1. Modify the <u>Table 4 3. Power consumption characteristics</u> . Add test conditions and parameters in Deep-Sleep and Standby mode	Jun.1, 2021
2.5	1. Modified the description of zero wait in Code Flash, refer to <u>ARM® Cortex®-M3 core</u> . 2. Update the pin names of EXMC_NL, EXMC_A16 and EXMC_A17 to EXMC_NL/EXMC_NADV, EXMC_A16/EXMC_CLE, and EXMC_A17/EXMC_ALE, refer to <u>Pin definitions</u> . 3. Update the <u>Electrical characteristics</u> covering most chapter.	Jul.18, 2022
2.6	1. Modify the cover, add version and time information. 2. Change the prefix to uppercase and change VREF+ to VREFP and VREF- to VREFN, refer to <u>Pin definitions</u> and <u>Figure 4-1</u> . 3. The pin definitions table header adds chip package information.	Jun.10, 2023
2.7	1. Added backup domain I/O drive current capabilities, refer to <u>GPIO characteristic</u> .	Jan.4, 2024

Important Notice

This document is the property of GigaDevice Semiconductor Inc. and its subsidiaries (the "Company"). This document, including any product of the Company described in this document (the "Product"), is owned by the Company under the intellectual property laws and treaties of the People's Republic of China and other jurisdictions worldwide. The Company reserves all rights under such laws and treaties and does not grant any license under its patents, copyrights, trademarks, or other intellectual property rights. The names and brands of third party referred thereto (if any) are the property of their respective owner and referred to for identification purposes only.

The Company makes no warranty of any kind, express or implied, with regard to this document or any Product, including, but not limited to, the implied warranties of merchantability and fitness for a particular purpose. The Company does not assume any liability arising out of the application or use of any Product described in this document. Any information provided in this document is provided only for reference purposes. It is the responsibility of the user of this document to properly design, program, and test the functionality and safety of any application made of this information and any resulting product. Except for customized products which has been expressly identified in the applicable agreement, the Products are designed, developed, and/or manufactured for ordinary business, industrial, personal, and/or household applications only. The Products are not designed, intended, or authorized for use as components in systems designed or intended for the operation of weapons, weapons systems, nuclear installations, atomic energy control instruments, combustion control instruments, airplane or spaceship instruments, transportation instruments, traffic signal instruments, life-support devices or systems, other medical devices or systems (including resuscitation equipment and surgical implants), pollution control or hazardous substances management, or other uses where the failure of the device or Product could cause personal injury, death, property or environmental damage ("Unintended Uses"). Customers shall take any and all actions to ensure using and selling the Products in accordance with the applicable laws and regulations. The Company is not liable, in whole or in part, and customers shall and hereby do release the Company as well as its suppliers and/or distributors from any claim, damage, or other liability arising from or related to all Unintended Uses of the Products. Customers shall indemnify and hold the Company as well as its suppliers and/or distributors harmless from and against all claims, costs, damages, and other liabilities, including claims for personal injury or death, arising from or related to any Unintended Uses of the Products.

Information in this document is provided solely in connection with the Products. The Company reserves the right to make changes, corrections, modifications or improvements to this document and Products and services described herein at any time, without notice.