

GigaDevice Semiconductor Inc.

GD32VF103
RISC-V 32-bit MCU

Datasheet

Revision 2.1

(Jan. 2025)



Table of Contents

Table of Contents	1
List of Figures	4
List of Tables	5
1. General description	7
2. Device overview	8
2.1. Device information	8
2.2. Block diagram	10
2.3. Pinouts and pin assignment	11
2.4. Memory map	14
2.5. Clock tree	18
2.6. Pin definitions	19
2.6.1. GD32VF103Vx LQFP100 pin definitions	19
2.6.2. GD32VF103Rx LQFP64 pin definitions	26
2.6.3. GD32VF103Cx LQFP48 pin definitions	30
2.6.4. GD32VF103Tx QFN36 pin definitions	34
3. Functional description	37
3.1. System and memory architecture	37
3.2. On-chip memory	37
3.3. Clock, reset and supply management	37
3.4. Boot modes	38
3.5. Power saving modes	39
3.6. Analog to digital converter (ADC)	39
3.7. Digital to analog converter (DAC)	40
3.8. DMA	40
3.9. General-purpose inputs/outputs (GPIOs)	40
3.10. Timers and PWM generation	41
3.11. Real time clock (RTC)	42
3.12. Inter-integrated circuit (I2C)	42
3.13. Serial peripheral interface (SPI)	44
3.14. Universal synchronous asynchronous receiver transmitter (USART)	44



3.15.	Inter-IC sound (I2S)	44
3.16.	Universal serial bus full-speed (USBFS)	45
3.17.	Controller area network (CAN)	45
3.18.	External memory controller (EXMC)	45
3.19.	Debug mode	45
3.20.	Package and operation temperature	46
4.	Electrical characteristics	47
4.1.	Absolute maximum ratings	47
4.2.	Operating conditions characteristics	47
4.3.	Power consumption	49
4.4.	EMC characteristics	53
4.5.	Power supply supervisor characteristics	54
4.6.	Electrical sensitivity	55
4.7.	External clock characteristics	55
4.8.	Internal clock characteristics	57
4.9.	PLL characteristics	58
4.10.	Memory characteristics	59
4.11.	NRST pin characteristics	59
4.12.	GPIO characteristics	60
4.13.	ADC characteristics	62
4.14.	Temperature sensor characteristics	63
4.15.	DAC characteristics	63
4.16.	I2C characteristics	64
4.17.	SPI characteristics	65
4.18.	I2S characteristics	67
4.19.	USART characteristics	69
4.20.	CAN characteristics	69
4.21.	USBFS characteristics	70
4.22.	EXMC characteristics	70
4.23.	TIMER characteristics	71
4.24.	WDGT characteristics	72



4.25. Parameter conditions.....	72
5. Package information.....	73
5.1. LQFP100 package outline dimensions.....	73
5.2. LQFP64 package outline dimensions.....	75
5.3. LQFP48 package outline dimensions.....	77
5.4. QFN36 package outline dimensions	79
5.5. Thermal characteristics	81
6. Ordering information	83
7. Revision History.....	84



List of Figures

Figure 2-1. GD32VF103 block diagram	10
Figure 2-2. GD32VF103Vx LQFP100 pinouts.....	11
Figure 2-3. GD32VF103Rx LQFP64 pinouts	12
Figure 2-4. GD32VF103Cx LQFP48 pinouts	13
Figure 2-5. GD32VF103Tx QFN36 pinouts	13
Figure 2-6. GD32VF103 clock tree	18
Figure 4-1. Recommended power supply decoupling capacitors ⁽¹⁾⁽²⁾	48
Figure 4-2. Typical supply current consumption in Run mode.....	53
Figure 4-3. Typical supply current consumption in Sleep mode.....	53
Figure 4-4. Recommended external NRST pin circuit ⁽¹⁾	60
Figure 4-5. I/O port AC characteristics definition	61
Figure 4-6. I2C bus timing diagram	65
Figure 4-7. SPI timing diagram - master mode	66
Figure 4-8. SPI timing diagram - slave mode	67
Figure 4-9. I2S timing diagram - master mode.....	68
Figure 4-10. I2S timing diagram - slave mode.....	69
Figure 4-11. USBFS timings: definition of data signal rise and fall time	70
Figure 5-1. LQFP100 package outline	73
Figure 5-2. LQFP100 recommended footprint.....	74
Figure 5-3. LQFP64 package outline	75
Figure 5-4. LQFP64 recommended footprint.....	76
Figure 5-5. LQFP48 package outline	77
Figure 5-6. LQFP48 recommended footprint.....	78
Figure 5-7. QFN36 package outline	79
Figure 5-8. QFN36 recommended footprint.....	80

List of Tables

Table 2-1. GD32VF103 devices features and peripheral list (LQFP64, LQFP100)	8
Table 2-2. GD32VF103 devices features and peripheral list (QFN36, LQFP48)	9
Table 2-3. GD32VF103 memory map	14
Table 2-4. GD32VF103Vx LQFP100 pin definitions	19
Table 2-5. GD32VF103Rx LQFP64 pin definitions	26
Table 2-6. GD32VF103Cx LQFP48 pin definitions	30
Table 2-7. GD32VF103Tx QFN36 pin definitions	34
Table 4-1. Absolute maximum ratings ⁽¹⁾⁽⁴⁾	47
Table 4-2. DC operating conditions	47
Table 4-3. Clock frequency ⁽¹⁾	48
Table 4-4. Operating conditions at Power up/ Power down ⁽¹⁾	48
Table 4-5. Start-up timings of Operating conditions ⁽¹⁾⁽²⁾⁽³⁾	48
Table 4-6. Power saving mode wakeup timings characteristics ⁽¹⁾⁽²⁾	48
Table 4-7. Power consumption characteristics ⁽²⁾⁽³⁾⁽⁴⁾⁽⁵⁾⁽⁶⁾	49
Table 4-8. EMS characteristics ⁽¹⁾	54
Table 4-9. Power supply supervisor characteristics	54
Table 4-10. ESD characteristics ⁽¹⁾	55
Table 4-11. Static latch-up characteristics ⁽¹⁾	55
Table 4-12. High speed external clock (HXTAL) generated from a crystal/ceramic	55
Table 4-13. High speed external clock characteristics (HXTAL in bypass mode)	56
Table 4-14. Low speed external clock (LXTAL) generated from a crystal/ceramic characteristics	56
Table 4-15. Low speed external user clock characteristics (LXTAL in bypass mode)	57
Table 4-16. High speed internal clock (IRC8M) characteristics	57
Table 4-17. Low speed internal clock (IRC40K) characteristics	58
Table 4-18. PLL characteristics	58
Table 4-19. PLL1/2 characteristics	58
Table 4-20. Flash memory characteristics	59
Table 4-21. NRST pin characteristics	59
Table 4-22. I/O port DC characteristics ⁽¹⁾⁽³⁾	60
Table 4-23. I/O port AC characteristics ⁽¹⁾⁽²⁾	61
Table 4-24. ADC characteristics	62
Table 4-25. ADC R_{AIN} max for $f_{ADC} = 14$ MHz ⁽¹⁾	62
Table 4-26. Temperature sensor characteristics ⁽¹⁾	63
Table 4-27. DAC characteristics	63
Table 4-28. I2C characteristics ⁽¹⁾⁽²⁾	64
Table 4-29. Standard SPI characteristics ⁽¹⁾	65
Table 4-30. I2S characteristics ⁽¹⁾⁽²⁾	67
Table 4-31. USART0 characteristics ⁽¹⁾	69
Table 4-32. USART1-2/UART3-4 characteristics ⁽¹⁾	69



Table 4-33. USBFS start up time.....	70
Table 4-34. USBFS DC electrical characteristics.....	70
Table 4-35. USBFS electrical characteristics ⁽¹⁾	70
Table 4-36. Asynchronous multiplexed PSRAM/NOR read timings ⁽¹⁾⁽²⁾⁽³⁾	70
Table 4-37. Asynchronous multiplexed PSRAM/NOR write timings ⁽¹⁾⁽²⁾⁽³⁾	71
Table 4-38. TIMER characteristics ⁽¹⁾	71
Table 4-39. FWDGT min/max timeout period at 40 kHz (IRC40K) ⁽¹⁾	72
Table 4-40. WWDGT min/max timeout value at 54 MHz (f _{PCLK1}) ⁽¹⁾	72
Table 5-1. LQFP100 package dimensions.....	73
Table 5-2. LQFP64 package dimensions.....	75
Table 5-3. LQFP48 package dimensions.....	77
Table 5-4. QFN36 package dimensions.....	79
Table 5-5. Package thermal characteristics ⁽¹⁾	81
Table 6-1. Part ordering code for GD32VF103xx devices.....	83
Table 7-1. Revision history.....	84

1. General description

The GD32VF103 device is a 32-bit general-purpose microcontroller based on the RISC-V core with best ratio in terms of processing power, reduced power consumption and peripheral set. The RISC-V processor core is tightly coupled with an Enhancement Core-Local Interrupt Controller (ECLIC), SysTick timer and advanced debug support.

The GD32VF103 device incorporates the RISC-V 32-bit processor core operating at 108 MHz frequency with Flash accesses zero wait states to obtain maximum efficiency. It provides up to 128 KB on-chip Flash memory and 32 KB SRAM memory. An extensive range of enhanced I/Os and peripherals connect to two APB buses. The devices offer up to two 12-bit ADCs, one 12-bit DAC, up to four general 16-bit timers, two basic timers plus a PWM advanced timer, as well as standard and advanced communication interfaces: up to three SPIs, two I2Cs, three USARTs, two UARTs, two I2Ss, two CANs, an USBFS.

The device operates from a 2.6 to 3.6 V power supply and available in -40 to $+85$ °C temperature range. Several power saving modes provide the flexibility for maximum optimization between wakeup latency and power consumption, an especially important consideration in low power applications.

The above features make the GD32VF103 devices suitable for a wide range of interconnection applications, especially in areas such as industrial control, motor drives, power monitor and alarm systems, consumer and handheld equipment, POS, vehicle GPS, LED display and so on.

2. Device overview

2.1. Device information

Table 2-1. GD32VF103 devices features and peripheral list (LQFP64, LQFP100)

Part Number		GD32VF103					
		RB	R8	R6	R4	VB	V8
Flash (KB)		128	64	32	16	128	64
SRAM (KB)		32	20	10	6	32	20
Timers	General timer(16-bit)	4 <small>(1-4)</small>	4 <small>(1-4)</small>	2 <small>(1-2)</small>	2 <small>(1-2)</small>	4 <small>(1-4)</small>	4 <small>(1-4)</small>
	Advanced timer(16-bit)	1 <small>(0)</small>	1 <small>(0)</small>	1 <small>(0)</small>	1 <small>(0)</small>	1 <small>(0)</small>	1 <small>(0)</small>
	SysTick	1	1	1	1	1	1
	Basic timer(16-bit)	2 <small>(5-6)</small>	2 <small>(5-6)</small>	2 <small>(5-6)</small>	2 <small>(5-6)</small>	2 <small>(5-6)</small>	2 <small>(5-6)</small>
	Watchdog	2	2	2	2	2	2
	RTC	1	1	1	1	1	1
Connectivity	U(S)ART	5	5	2	2	5	5
	I2C	2 <small>(0-1)</small>	2 <small>(0-1)</small>	1	1	2 <small>(0-1)</small>	2 <small>(0-1)</small>
	SPI/I2S	3/2 <small>(0-2) / (1-2)</small>	3/2 <small>(0-2) / (1-2)</small>	1/-	1/-	3/2 <small>(0-2) / (1-2)</small>	3/2 <small>(0-2) / (1-2)</small>
	CAN	2	2	2	2	2	2
	USBFS	1	1	1	1	1	1
GPIO		51	51	51	51	80	80
EXMC		-	-	-	-	1	1
EXTI		16	16	16	16	16	16
ADC	Units	2	2	2	2	2	2
	Channels	16	16	16	16	16	16
DAC	Units	1	1	1	1	1	1
	Channels	2	2	2	2	2	2
Package		LQFP64				LQFP100	

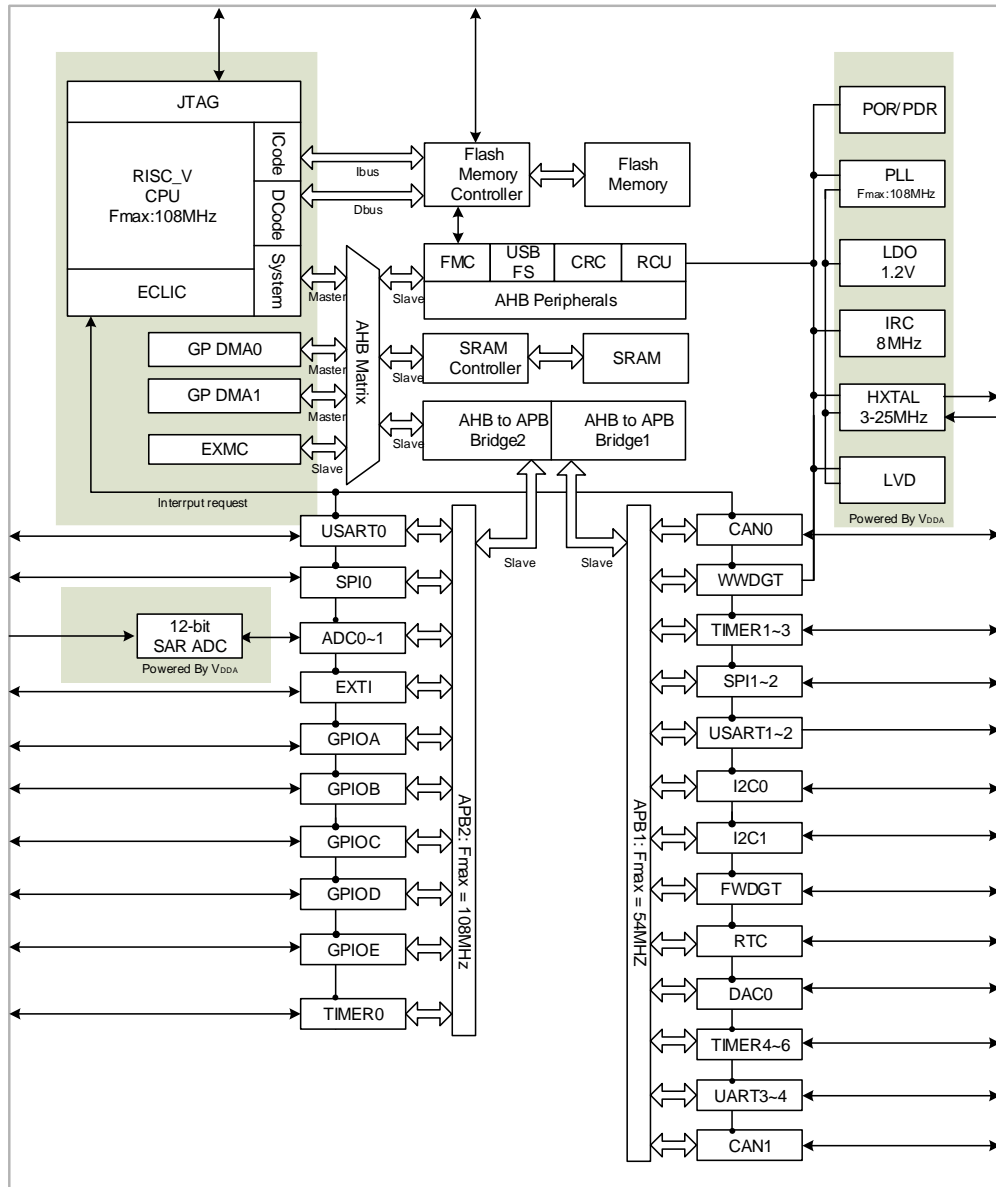

Table 2-2. GD32VF103 devices features and peripheral list (QFN36, LQFP48)

Part Number		GD32VF103							
		TB	T8	T6	T4	CB	C8	C6	C4
Flash (KB)		128	64	32	16	128	64	32	16
SRAM (KB)		32	20	10	6	32	20	10	6
Timers	General timer(16-bit)	4 <small>(1-4)</small>	4 <small>(1-4)</small>	2 <small>(1-2)</small>	2 <small>(1-2)</small>	4 <small>(1-4)</small>	4 <small>(1-4)</small>	2 <small>(1-2)</small>	2 <small>(1-2)</small>
	Advanced timer(16-bit)	1 <small>(0)</small>	1 <small>(0)</small>	1 <small>(0)</small>	1 <small>(0)</small>	1 <small>(0)</small>	1 <small>(0)</small>	1 <small>(0)</small>	1 <small>(0)</small>
	SysTick	1	1	1	1	1	1	1	1
	Basic timer(16-bit)	2 <small>(5-6)</small>	2 <small>(5-6)</small>	2 <small>(5-6)</small>	2 <small>(5-6)</small>	2 <small>(5-6)</small>	2 <small>(5-6)</small>	2 <small>(5-6)</small>	2 <small>(5-6)</small>
	Watchdog	2	2	2	2	2	2	2	2
	RTC	1	1	1	1	1	1	1	1
Connectivity	U(S)ART	2	2	2	2	3	3	2	2
	I2C	1	1	1	1	2 <small>(0-1)</small>	2 <small>(0-1)</small>	1	1
	SPI/I2S	1/-	1/-	1/-	1/-	3/2 <small>(0-2) / (1-2)</small>	3/2 <small>(0-2) / (1-2)</small>	1/-	1/-
	CAN	2	2	2	2	2	2	2	2
	USBFS	1	1	1	1	1	1	1	1
GPIO		26	26	26	26	37	37	37	37
EXMC		-	-	-	-	-	-	-	-
EXTI		16	16	16	16	16	16	16	16
ADC	Units	2	2	2	2	2	2	2	2
	Channels	10	10	10	10	10	10	10	10
DAC	Units	1	1	1	1	1	1	1	1
	Channels	2	2	2	2	2	2	2	2
Package		QFN36				LQFP48			

2.2. Block diagram

Figure 2-1. GD32VF103 block diagram



2.3. Pinouts and pin assignment

Figure 2-2. GD32VF103Vx LQFP100 pinouts

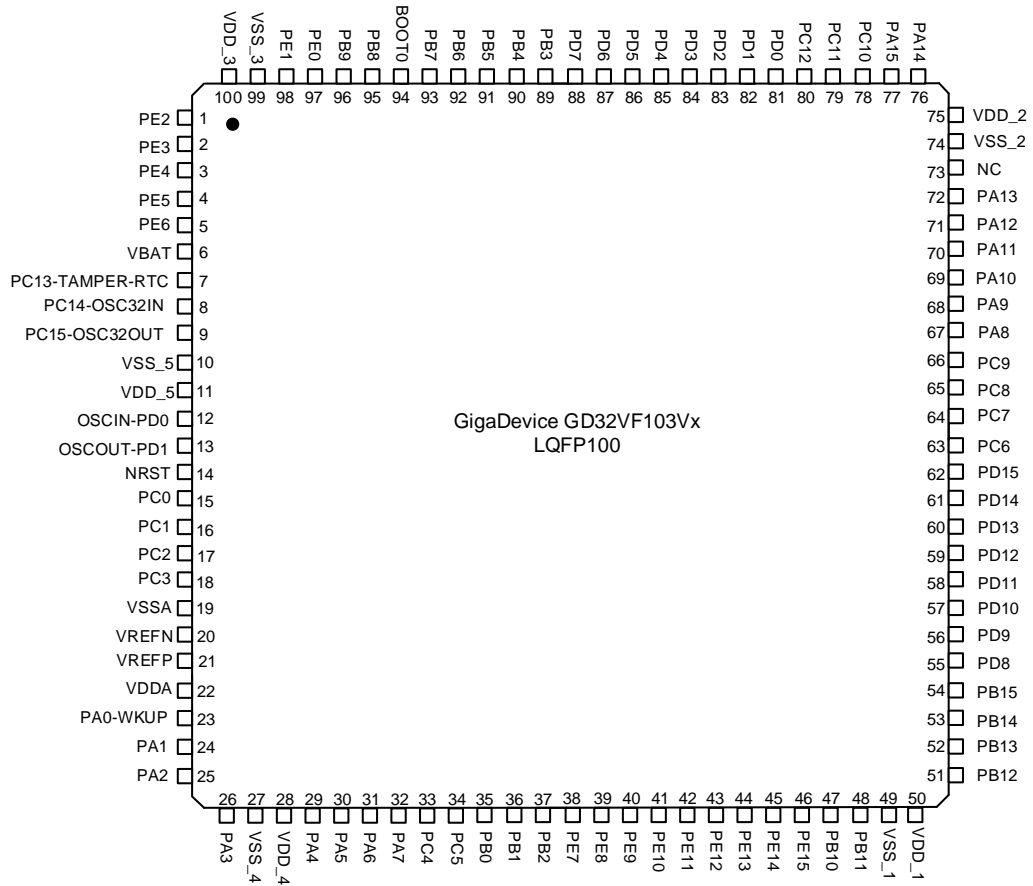

Figure 2-3. GD32VF103Rx LQFP64 pinouts

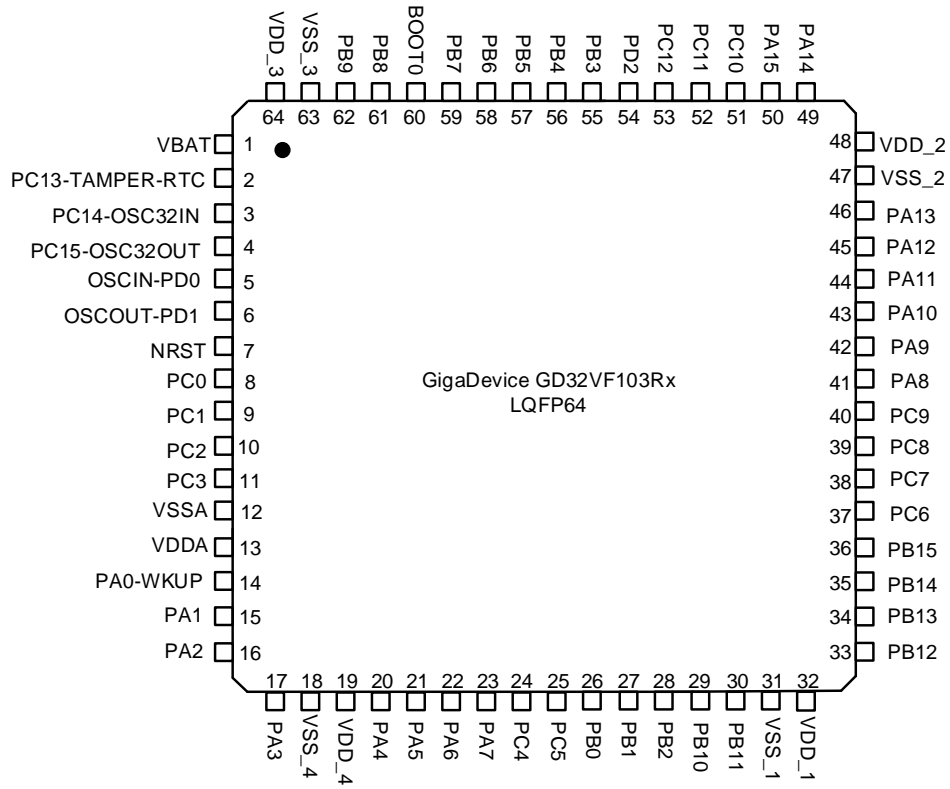

Figure 2-4. GD32VF103Cx LQFP48 pinouts

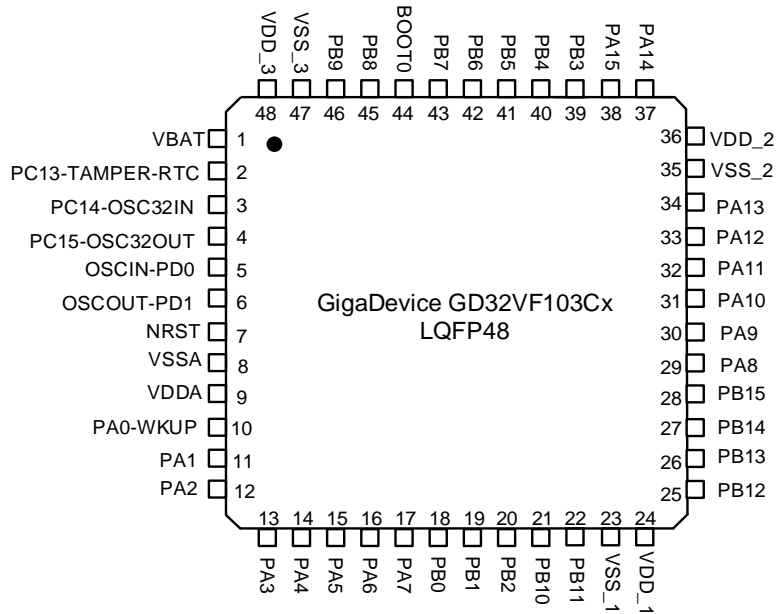
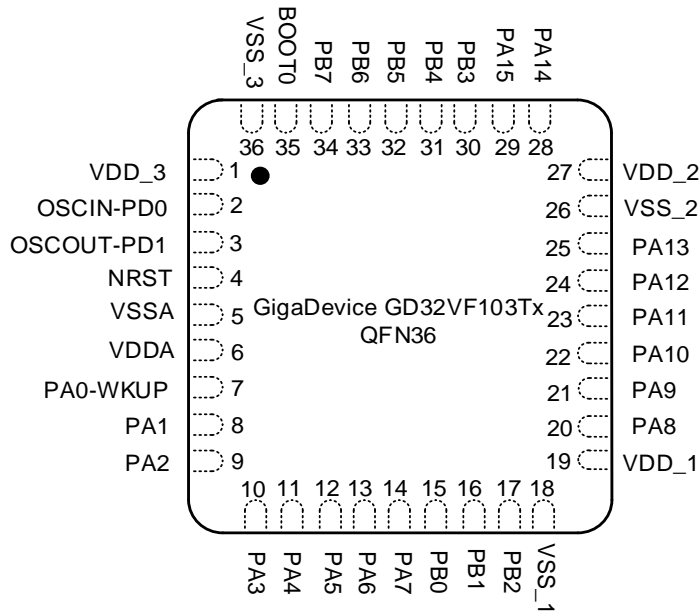

Figure 2-5. GD32VF103Tx QFN36 pinouts



2.4. Memory map

Table 2-3. GD32VF103 memory map

Pre-defined Regions	Bus	Address	Peripherals
External device	AHB	0xA000 0000 - 0xA000 0FFF	EXMC_SWREG
External RAM		0x9000 0000 - 0x9FFF FFFF	Reserved
		0x7000 0000 - 0x8FFF FFFF	Reserved
Peripheral	AHB	0x6000 0000 - 0x6FFF FFFF	EXMC - NOR/PSRAM/SRAM
		0x5000 0000 - 0x5003 FFFF	USBFS
		0x4008 0000 - 0x4FFF FFFF	Reserved
		0x4004 0000 - 0x4007 FFFF	Reserved
		0x4002 BC00 - 0x4003 FFFF	Reserved
		0x4002 B000 - 0x4002 BBFF	Reserved
		0x4002 A000 - 0x4002 AFFF	Reserved
		0x4002 8000 - 0x4002 9FFF	Reserved
		0x4002 6800 - 0x4002 7FFF	Reserved
		0x4002 6400 - 0x4002 67FF	Reserved
		0x4002 6000 - 0x4002 63FF	Reserved
		0x4002 5000 - 0x4002 5FFF	Reserved
		0x4002 4000 - 0x4002 4FFF	Reserved
		0x4002 3C00 - 0x4002 3FFF	Reserved
		0x4002 3800 - 0x4002 3BFF	Reserved
		0x4002 3400 - 0x4002 37FF	Reserved
		0x4002 3000 - 0x4002 33FF	CRC
		0x4002 2C00 - 0x4002 2FFF	Reserved
		0x4002 2800 - 0x4002 2BFF	Reserved
		0x4002 2400 - 0x4002 27FF	Reserved
		0x4002 2000 - 0x4002 23FF	FMC
		0x4002 1C00 - 0x4002 1FFF	Reserved
		0x4002 1800 - 0x4002 1BFF	Reserved
		0x4002 1400 - 0x4002 17FF	Reserved
		0x4002 1000 - 0x4002 13FF	RCU
		0x4002 0C00 - 0x4002 0FFF	Reserved
		0x4002 0800 - 0x4002 0BFF	Reserved
		0x4002 0400 - 0x4002 07FF	DMA1
0x4002 0000 - 0x4002 03FF	DMA0		
0x4001 8400 - 0x4001 FFFF	Reserved		



Pre-defined Regions	Bus	Address	Peripherals	
		0x4001 8000 - 0x4001 83FF	Reserved	
	APB2	0x4001 7C00 - 0x4001 7FFF	Reserved	
		0x4001 7800 - 0x4001 7BFF	Reserved	
		0x4001 7400 - 0x4001 77FF	Reserved	
		0x4001 7000 - 0x4001 73FF	Reserved	
		0x4001 6C00 - 0x4001 6FFF	Reserved	
		0x4001 6800 - 0x4001 6BFF	Reserved	
		0x4001 5C00 - 0x4001 67FF	Reserved	
		0x4001 5800 - 0x4001 5BFF	Reserved	
		0x4001 5400 - 0x4001 57FF	Reserved	
		0x4001 5000 - 0x4001 53FF	Reserved	
		0x4001 4C00 - 0x4001 4FFF	Reserved	
		0x4001 4800 - 0x4001 4BFF	Reserved	
		0x4001 4400 - 0x4001 47FF	Reserved	
		0x4001 4000 - 0x4001 43FF	Reserved	
		0x4001 3C00 - 0x4001 3FFF	Reserved	
		0x4001 3800 - 0x4001 3BFF	USART0	
		0x4001 3400 - 0x4001 37FF	Reserved	
		0x4001 3000 - 0x4001 33FF	SPI0	
		0x4001 2C00 - 0x4001 2FFF	TIMER0	
		0x4001 2800 - 0x4001 2BFF	ADC1	
		0x4001 2400 - 0x4001 27FF	ADC0	
		0x4001 2000 - 0x4001 23FF	Reserved	
		0x4001 1C00 - 0x4001 1FFF	Reserved	
		0x4001 1800 - 0x4001 1BFF	GPIOE	
		0x4001 1400 - 0x4001 17FF	GPIOD	
		0x4001 1000 - 0x4001 13FF	GPIOC	
		0x4001 0C00 - 0x4001 0FFF	GPIOB	
		0x4001 0800 - 0x4001 0BFF	GPIOA	
		0x4001 0400 - 0x4001 07FF	EXTI	
		0x4001 0000 - 0x4001 03FF	AFIO	
		APB1	0x4000 CC00 - 0x4000 FFFF	Reserved
			0x4000 C800 - 0x4000 CBFF	Reserved
			0x4000 C400 - 0x4000 C7FF	Reserved
	0x4000 C000 - 0x4000 C3FF		Reserved	
	0x4000 8000 - 0x4000 BFFF		Reserved	
	0x4000 7C00 - 0x4000 7FFF		Reserved	
	0x4000 7800 - 0x4000 7BFF		Reserved	
	0x4000 7400 - 0x4000 77FF		DAC0	
	0x4000 7000 - 0x4000 73FF		PMU	



Pre-defined Regions	Bus	Address	Peripherals
		0x4000 6C00 - 0x4000 6FFF	BKP
		0x4000 6800 - 0x4000 6BFF	CAN1
		0x4000 6400 - 0x4000 67FF	CAN0
		0x4000 6000 - 0x4000 63FF	Shared USB/CAN SRAM 512bytes
		0x4000 5C00 - 0x4000 5FFF	USB device FS registers
		0x4000 5800 - 0x4000 5BFF	I2C1
		0x4000 5400 - 0x4000 57FF	I2C0
		0x4000 5000 - 0x4000 53FF	UART4
		0x4000 4C00 - 0x4000 4FFF	UART3
		0x4000 4800 - 0x4000 4BFF	USART2
		0x4000 4400 - 0x4000 47FF	USART1
		0x4000 4000 - 0x4000 43FF	Reserved
		0x4000 3C00 - 0x4000 3FFF	SPI2/I2S2
		0x4000 3800 - 0x4000 3BFF	SPI1/I2S1
		0x4000 3400 - 0x4000 37FF	Reserved
		0x4000 3000 - 0x4000 33FF	FWDGT
		0x4000 2C00 - 0x4000 2FFF	WWDGT
		0x4000 2800 - 0x4000 2BFF	RTC
		0x4000 2400 - 0x4000 27FF	Reserved
		0x4000 2000 - 0x4000 23FF	Reserved
		0x4000 1C00 - 0x4000 1FFF	Reserved
		0x4000 1800 - 0x4000 1BFF	Reserved
		0x4000 1400 - 0x4000 17FF	TIMER6
		0x4000 1000 - 0x4000 13FF	TIMER5
		0x4000 0C00 - 0x4000 0FFF	TIMER4
		0x4000 0800 - 0x4000 0BFF	TIMER3
0x4000 0400 - 0x4000 07FF	TIMER2		
0x4000 0000 - 0x4000 03FF	TIMER1		
SRAM	AHB	0x2007 0000 - 0x3FFF FFFF	Reserved
		0x2006 0000 - 0x2006 FFFF	Reserved
		0x2003 0000 - 0x2005 FFFF	Reserved
		0x2002 0000 - 0x2002 FFFF	Reserved
		0x2001 C000 - 0x2001 FFFF	Reserved
		0x2000 8000 - 0x2001 BFFF	Reserved
		0x2000 0000 - 0x2000 7FFF	SRAM
Code	AHB	0x1FFF F810 - 0x1FFF FFFF	Reserved
		0x1FFF F800 - 0x1FFF F80F	Option Bytes
		0x1FFF B000 - 0x1FFF F7FF	Boot loader



Pre-defined Regions	Bus	Address	Peripherals
		0x1FFF 7A10 - 0x1FFF AFFF	Reserved
		0x1FFF 7800 - 0x1FFF 7A0F	Reserved
		0x1FFF 0000 - 0x1FFF 77FF	Reserved
		0x1FFE C010 - 0x1FFE FFFF	Reserved
		0x1FFE C000 - 0x1FFE C00F	Reserved
		0x1001 0000 - 0x1FFE BFFF	Reserved
		0x1000 0000 - 0x1000 FFFF	Reserved
		0x083C 0000 - 0x0FFF FFFF	Reserved
		0x0830 0000 - 0x083B FFFF	Reserved
		0x0802 0000 - 0x082F FFFF	Reserved
		0x0800 0000 - 0x0801 FFFF	Main Flash
		0x0030 0000 - 0x07FF FFFF	Reserved
		0x0000 0000 - 0x002F FFFF	Aliased to Main Flash or Boot loader

2.5. Clock tree

Figure 2-6. GD32VF103 clock tree

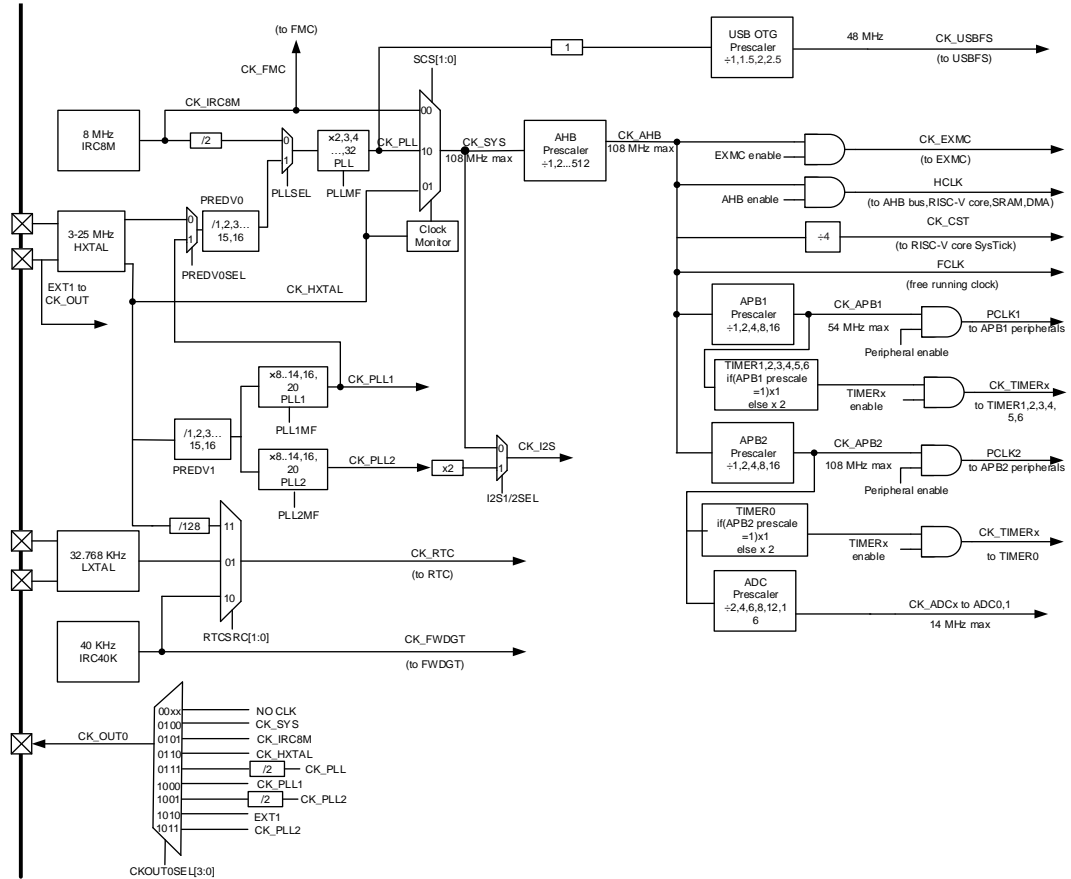

Legend:

HXTAL: High speed external clock

LXTAL: Low speed external clock

IRC8M: High speed internal clock

IRC40K: Low speed internal clock

2.6. Pin definitions

2.6.1. GD32VF103Vx LQFP100 pin definitions

Table 2-4. GD32VF103Vx LQFP100 pin definitions

GD32VF103Vx LQFP100				
Pin Name	Pins	Pin Type ⁽¹⁾	I/O Level ⁽²⁾	Functions description
PE2	1	I/O	5VT	Default: PE2 Alternate: EXMC_A23
PE3	2	I/O	5VT	Default: PE3 Alternate: EXMC_A19
PE4	3	I/O	5VT	Default: PE4 Alternate: EXMC_A20
PE5	4	I/O	5VT	Default: PE5 Alternate: EXMC_A21
PE6	5	I/O	5VT	Default: PE6 Alternate: EXMC_A22
VBAT	6	P		Default: VBAT
PC13- TAMPER- RTC	7	I/O		Default: PC13 Alternate: TAMPER-RTC
PC14- OSC32IN	8	I/O		Default: PC14 Alternate: OSC32IN
PC15- OSC32OUT	9	I/O		Default: PC15 Alternate: OSC32OUT
VSS_5	10	P		Default: VSS_5
VDD_5	11	P		Default: VDD_5
OSCIN-PD0	12	I		Default: OSCIN Remap: PD0
OSCOUT- PD1	13	O		Default: OSCOUT Remap: PD1
NRST	14	I/O		Default: NRST
PC0	15	I/O		Default: PC0 Alternate: ADC01_IN10
PC1	16	I/O		Default: PC1 Alternate: ADC01_IN11
PC2	17	I/O		Default: PC2 Alternate: ADC01_IN12
PC3	18	I/O		Default: PC3 Alternate: ADC01_IN13



GD32VF103Vx LQFP100				
Pin Name	Pins	Pin Type ⁽¹⁾	I/O Level ⁽²⁾	Functions description
VSSA	19	P		Default: VSSA
VREFN	20	P		Default: VREFN
VREFP	21	P		Default: VREFP
VDDA	22	P		Default: VDDA
PA0-WKUP	23	I/O		Default: PA0 Alternate: WKUP, USART1_CTS, ADC01_IN0, TIMER1_CH0_ETI, TIMER4_CH0,
PA1	24	I/O		Default: PA1 Alternate: USART1_RTS, ADC01_IN1, TIMER1_CH1, TIMER4_CH1,
PA2	25	I/O		Default: PA2 Alternate: USART1_TX, ADC01_IN2, TIMER1_CH2, TIMER4_CH2
PA3	26	I/O		Default: PA3 Alternate: USART1_RX, ADC01_IN3, TIMER1_CH3, TIMER4_CH3
VSS_4	27	P		Default: VSS_4
VDD_4	28	P		Default: VDD_4
PA4	29	I/O		Default: PA4 Alternate: SPI0_NSS, USART1_CK, ADC01_IN4, DAC0_OUT0 Remap: SPI2_NSS, I2S2_WS
PA5	30	I/O		Default: PA5 Alternate: SPI0_SCK, ADC01_IN5, DAC0_OUT1
PA6	31	I/O		Default: PA6 Alternate: SPI0_MISO, ADC01_IN6, TIMER2_CH0 Remap: TIMER0_BRKIN
PA7	32	I/O		Default: PA7 Alternate: SPI0_MOSI, ADC01_IN7, TIMER2_CH1 Remap: TIMER0_CH0_ON
PC4	33	I/O		Default: PC4 Alternate: ADC01_IN14
PC5	34	I/O		Default: PC5 Alternate: ADC01_IN15
PB0	35	I/O		Default: PB0 Alternate: ADC01_IN8, TIMER2_CH2 Remap: TIMER0_CH1_ON
PB1	36	I/O		Default: PB1 Alternate: ADC01_IN9, TIMER2_CH3



GD32VF103Vx LQFP100				
Pin Name	Pins	Pin Type ⁽¹⁾	I/O Level ⁽²⁾	Functions description
				Remap: TIMER0_CH2_ON
PB2	37	I/O	5VT	Default: PB2, BOOT1
PE7	38	I/O	5VT	Default: PE7 Alternate: EXMC_D4 Remap: TIMER0_ETI
PE8	39	I/O	5VT	Default: PE8 Alternate: EXMC_D5 Remap: TIMER0_CH0_ON
PE9	40	I/O	5VT	Default: PE9 Alternate: EXMC_D6 Remap: TIMER0_CH0
PE10	41	I/O	5VT	Default: PE10 Alternate: EXMC_D7 Remap: TIMER0_CH1_ON
PE11	42	I/O	5VT	Default: PE11 Alternate: EXMC_D8 Remap: TIMER0_CH1
PE12	43	I/O	5VT	Default: PE12 Alternate: EXMC_D9 Remap: TIMER0_CH2_ON
PE13	44	I/O	5VT	Default: PE13 Alternate: EXMC_D10 Remap: TIMER0_CH2
PE14	45	I/O	5VT	Default: PE14 Alternate: EXMC_D11 Remap: TIMER0_CH3
PE15	46	I/O	5VT	Default: PE15 Alternate: EXMC_D12 Remap: TIMER0_BRKIN
PB10	47	I/O	5VT	Default: PB10 Alternate: I2C1_SCL, USART2_TX, Remap: TIMER1_CH2
PB11	48	I/O	5VT	Default: PB11 Alternate: I2C1_SDA, USART2_RX Remap: TIMER1_CH3
VSS_1	49	P		Default: VSS_1
VDD_1	50	P		Default: VDD_1
PB12	51	I/O	5VT	Default: PB12



GD32VF103Vx LQFP100				
Pin Name	Pins	Pin Type ⁽¹⁾	I/O Level ⁽²⁾	Functions description
				Alternate: SPI1_NSS, I2C1_SMBA, USART2_CK, TIMER0_BRKIN, I2S1_WS, CAN1_RX
PB13	52	I/O	5VT	Default: PB13 Alternate: SPI1_SCK, USART2_CTS, TIMER0_CH0_ON, I2S1_CK, CAN1_TX,
PB14	53	I/O	5VT	Default: PB14 Alternate: SPI1_MISO, USART2_RTS, TIMER0_CH1_ON
PB15	54	I/O	5VT	Default: PB15 Alternate: SPI1_MOSI, TIMER0_CH2_ON, I2S1_SD
PD8	55	I/O	5VT	Default: PD8 Alternate: EXMC_D13 Remap: USART2_TX
PD9	56	I/O	5VT	Default: PD9 Alternate: EXMC_D14 Remap: USART2_RX
PD10	57	I/O	5VT	Default: PD10 Alternate: EXMC_D15 Remap: USART2_CK
PD11	58	I/O	5VT	Default: PD11 Alternate: EXMC_A16/EXMC_CLE Remap: USART2_CTS
PD12	59	I/O	5VT	Default: PD12 Alternate: EXMC_A17/EXMC_ALE Remap: TIMER3_CH0, USART2_RTS
PD13	60	I/O	5VT	Default: PD13 Alternate: EXMC_A18 Remap: TIMER3_CH1
PD14	61	I/O	5VT	Default: PD14 Alternate: EXMC_D0 Remap: TIMER3_CH2
PD15	62	I/O	5VT	Default: PD15 Alternate: EXMC_D1 Remap: TIMER3_CH3
PC6	63	I/O	5VT	Default: PC6 Alternate: I2S1_MCK Remap: TIMER2_CH0
PC7	64	I/O	5VT	Default: PC7 Alternate: I2S2_MCK



GD32VF103Vx LQFP100				
Pin Name	Pins	Pin Type ⁽¹⁾	I/O Level ⁽²⁾	Functions description
				Remap: TIMER2_CH1
PC8	65	I/O	5VT	Default: PC8 Remap: TIMER2_CH2
PC9	66	I/O	5VT	Default: PC9 Remap: TIMER2_CH3
PA8	67	I/O	5VT	Default: PA8 Alternate: USART0_CK, TIMER0_CH0, CK_OUT0, USBFS_SOF
PA9	68	I/O	5VT	Default: PA9 Alternate: USART0_TX, TIMER0_CH1, USBFS_VBUS
PA10	69	I/O	5VT	Default: PA10 Alternate: USART0_RX, TIMER0_CH2, USBFS_ID
PA11	70	I/O	5VT	Default: PA11 Alternate: USART0_CTS, CAN0_RX, USBFS_DM, TIMER0_CH3
PA12	71	I/O	5VT	Default: PA12 Alternate: USART0_RTS, USBFS_DP, CAN0_TX, TIMER0_ETI
PA13	72	I/O	5VT	Default: JTMS Remap: PA13
NC	73			-
VSS_2	74	P		Default: VSS_2
VDD_2	75	P		Default: VDD_2
PA14	76	I/O	5VT	Default: JTCK Remap: PA14
PA15	77	I/O	5VT	Default: JTDI Alternate: SPI2_NSS, I2S2_WS Remap: TIMER1_CH0_ETI, PA15, SPI0_NSS
PC10	78	I/O	5VT	Default: PC10 Alternate: UART3_TX Remap: USART2_TX, SPI2_SCK, I2S2_CK
PC11	79	I/O	5VT	Default: PC11 Alternate: UART3_RX Remap: USART2_RX, SPI2_MISO
PC12	80	I/O	5VT	Default: PC12 Alternate: UART4_TX Remap: USART2_CK, SPI2_MOSI, I2S2_SD
PD0	81	I/O	5VT	Default: PD0 Alternate: EXMC_D2



GD32VF103Vx LQFP100				
Pin Name	Pins	Pin Type ⁽¹⁾	I/O Level ⁽²⁾	Functions description
				Remap: CAN0_RX
PD1	82	I/O	5VT	Default: PD1 Alternate: EXMC_D3 Remap: CAN0_TX
PD2	83	I/O	5VT	Default: PD2 Alternate: TIMER2_ETI, UART4_RX
PD3	84	I/O	5VT	Default: PD3 Remap: USART1_CTS
PD4	85	I/O	5VT	Default: PD4 Alternate: EXMC_NOE Remap: USART1_RTS
PD5	86	I/O	5VT	Default: PD5 Alternate: EXMC_NWE Remap: USART1_TX
PD6	87	I/O	5VT	Default: PD6 Alternate: EXMC_NWAIT Remap: USART1_RX
PD7	88	I/O	5VT	Default: PD7 Alternate: EXMC_NE0 Remap: USART1_CK
PB3	89	I/O	5VT	Default: JTDO Alternate: SPI2_SCK, I2S2_CK Remap: PB3, TIMER1_CH1, SPI0_SCK
PB4	90	I/O	5VT	Default: NJTRST Alternate: SPI2_MISO Remap: TIMER2_CH0, PB4, SPI0_MISO
PB5	91	I/O		Default: PB5 Alternate: I2C0_SMBA, SPI2_MOSI, I2S2_SD Remap: TIMER2_CH1, SPI0_MOSI, CAN1_RX
PB6	92	I/O	5VT	Default: PB6 Alternate: I2C0_SCL, TIMER3_CH0 Remap: USART0_TX, CAN1_TX
PB7	93	I/O	5VT	Default: PB7 Alternate: I2C0_SDA, TIMER3_CH1, EXMC_NADV Remap: USART0_RX
BOOT0	94	I		Default: BOOT0
PB8	95	I/O	5VT	Default: PB8 Alternate: TIMER3_CH2



GD32VF103Vx LQFP100				
Pin Name	Pins	Pin Type ⁽¹⁾	I/O Level ⁽²⁾	Functions description
				Remap: I2C0_SCL, CAN0_RX
PB9	96	I/O	5VT	Default: PB9 Alternate: TIMER3_CH3 Remap: I2C0_SDA, CAN0_TX
PE0	97	I/O	5VT	Default: PE0 Alternate: TIMER3_ETI, EXMC_NBL0
PE1	98	I/O	5VT	Default: PE1 Alternate: EXMC_NBL1
VSS_3	99	P		Default: VSS_3
VDD_3	100	P		Default: VDD_3

Notes:

(1) Type: I = input, O = output, P = power.

(2) I/O Level: 5VT = 5 V tolerant.

2.6.2. GD32VF103Rx LQFP64 pin definitions

Table 2-5. GD32VF103Rx LQFP64 pin definitions

GD32VF103Rx LQFP64				
Pin Name	Pins	Pin Type ⁽¹⁾	I/O Level ⁽²⁾	Functions description
VBAT	1	P		Default: VBAT
PC13-TAMPER-RTC	2	I/O		Default: PC13 Alternate: TAMPER-RTC
PC14-OSC32IN	3	I/O		Default: PC14 Alternate: OSC32IN
PC15-OSC32OUT	4	I/O		Default: PC15 Alternate: OSC32OUT
OSCIN-PD0	5	I		Default: OSCIN Remap: PD0
OSCOUT-PD1	6	O		Default: OSCOUT Remap: PD1
NRST	7	I/O		Default: NRST
PC0	8	I/O		Default: PC0 Alternate: ADC01_IN10
PC1	9	I/O		Default: PC1 Alternate: ADC01_IN11
PC2	10	I/O		Default: PC2 Alternate: ADC01_IN12
PC3	11	I/O		Default: PC3 Alternate: ADC01_IN13
VSSA	12	P		Default: VSSA
VDDA	13	P		Default: VDDA
PA0-WKUP	14	I/O		Default: PA0 Alternate: WKUP, USART1_CTS, ADC01_IN0, TIMER1_CH0_ETI, TIMER4_CH0 ⁽³⁾
PA1	15	I/O		Default: PA1 Alternate: USART1_RTS, ADC01_IN1, TIMER1_CH1, TIMER4_CH1 ⁽³⁾
PA2	16	I/O		Default: PA2 Alternate: USART1_TX, ADC01_IN2, TIMER1_CH2, TIMER4_CH2 ⁽³⁾
PA3	17	I/O		Default: PA3 Alternate: USART1_RX, ADC01_IN3, TIMER1_CH3, TIMER4_CH3 ⁽³⁾



GD32VF103Rx LQFP64				
Pin Name	Pins	Pin Type ⁽¹⁾	I/O Level ⁽²⁾	Functions description
VSS_4	18	P		Default: VSS_4
VDD_4	19	P		Default: VDD_4
PA4	20	I/O		Default: PA4 Alternate: SPI0_NSS, USART1_CK, ADC01_IN4, DAC0_OUT0 Remap: SPI2_NSS ⁽³⁾ , I2S2_WS ⁽³⁾
PA5	21	I/O		Default: PA5 Alternate: SPI0_SCK, ADC01_IN5, DAC0_OUT1
PA6	22	I/O		Default: PA6 Alternate: SPI0_MISO, ADC01_IN6, TIMER2_CH0 Remap: TIMER0_BRKIN
PA7	23	I/O		Default: PA7 Alternate: SPI0_MOSI, ADC01_IN7, TIMER2_CH1 Remap: TIMER0_CH0_ON
PC4	24	I/O		Default: PC4 Alternate: ADC01_IN14
PC5	25	I/O		Default: PC5 Alternate: ADC01_IN15
PB0	26	I/O		Default: PB0 Alternate: ADC01_IN8, TIMER2_CH2, Remap: TIMER0_CH1_ON
PB1	27	I/O		Default: PB1 Alternate: ADC01_IN9, TIMER2_CH3, Remap: TIMER0_CH2_ON
PB2	28	I/O	5VT	Default: PB2, BOOT1
PB10	29	I/O	5VT	Default: PB10 Alternate: I2C1_SCL ⁽³⁾ , USART2_TX ⁽³⁾ , Remap: TIMER1_CH2
PB11	30	I/O	5VT	Default: PB11 Alternate: I2C1_SDA ⁽³⁾ , USART2_RX ⁽³⁾ , Remap: TIMER1_CH3
VSS_1	31	P		Default: VSS_1
VDD_1	32	P		Default: VDD_1
PB12	33	I/O	5VT	Default: PB12 Alternate: SPI1_NSS ⁽³⁾ , I2C1_SMBA ⁽³⁾ , USART2_CK ⁽³⁾ , TIMER0_BRKIN, I2S1_WS ⁽³⁾ , CAN1_RX
PB13	34	I/O	5VT	Default: PB13 Alternate: SPI1_SCK ⁽³⁾ , USART2_CTS ⁽³⁾ , TIMER0_CH0_ON, I2S1_CK ⁽³⁾ , CAN1_TX



GD32VF103Rx LQFP64				
Pin Name	Pins	Pin Type ⁽¹⁾	I/O Level ⁽²⁾	Functions description
PB14	35	I/O	5VT	Default: PB14 Alternate: SPI1_MISO ⁽³⁾ , USART2_RTS ⁽³⁾ , TIMER0_CH1_ON
PB15	36	I/O	5VT	Default: PB15 Alternate: SPI1_MOSI ⁽³⁾ , TIMER0_CH2_ON, I2S1_SD ⁽³⁾
PC6	37	I/O	5VT	Default: PC6 Alternate: I2S1_MCK ⁽³⁾ Remap: TIMER2_CH0
PC7	38	I/O	5VT	Default: PC7 Alternate: I2S2_MCK ⁽³⁾ Remap: TIMER2_CH1
PC8	39	I/O	5VT	Default: PC8 Remap: TIMER2_CH2
PC9	40	I/O	5VT	Default: PC9 Remap: TIMER2_CH3
PA8	41	I/O	5VT	Default: PA8 Alternate: USART0_CK, TIMER0_CH0, CK_OUT0, USBFS_SOF
PA9	42	I/O	5VT	Default: PA9 Alternate: USART0_TX, TIMER0_CH1, USBFS_VBUS
PA10	43	I/O	5VT	Default: PA10 Alternate: USART0_RX, TIMER0_CH2, USBFS_ID
PA11	44	I/O	5VT	Default: PA11 Alternate: USART0_CTS, CAN0_RX, USBFS_DM, TIMER0_CH3
PA12	45	I/O	5VT	Default: PA12 Alternate: USART0_RTS, USBFS_DP, CAN0_TX, TIMER0_ETI
PA13	46	I/O	5VT	Default: JTMS Remap: PA13
VSS_2	47	P		Default: VSS_2
VDD_2	48	P		Default: VDD_2
PA14	49	I/O	5VT	Default: JTCK Remap: PA14
PA15	50	I/O	5VT	Default: JTDI Alternate: SPI2_NSS ⁽³⁾ , I2S2_WS ⁽³⁾ Remap: TIMER1_CH0_ETI, PA15, SPI0_NSS
PC10	51	I/O	5VT	Default: PC10 Alternate: UART3_TX ⁽³⁾



GD32VF103Rx LQFP64				
Pin Name	Pins	Pin Type ⁽¹⁾	I/O Level ⁽²⁾	Functions description
				Remap: USART2_TX ⁽³⁾ , SPI2_SCK ⁽³⁾ , I2S2_CK ⁽³⁾
PC11	52	I/O	5VT	Default: PC11 Alternate: UART3_RX ⁽³⁾ Remap: USART2_RX ⁽³⁾ , SPI2_MISO ⁽³⁾
PC12	53	I/O	5VT	Default: PC12 Alternate: UART4_TX ⁽³⁾ Remap: USART2_CK ⁽³⁾ , SPI2_MOSI ⁽³⁾ , I2S2_SD ⁽³⁾
PD2	54	I/O	5VT	Default: PD2 Alternate: TIMER2_ETI, UART4_RX ⁽³⁾
PB3	55	I/O	5VT	Default: JTDO Alternate: SPI2_SCK ⁽³⁾ , I2S2_CK ⁽³⁾ Remap: PB3, TIMER1_CH1, SPI0_SCK
PB4	56	I/O	5VT	Default: NJTRST Alternate: SPI2_MISO ⁽³⁾ Remap: TIMER2_CH0, PB4, SPI0_MISO
PB5	57	I/O		Default: PB5 Alternate: I2C0_SMBA, SPI2_MOSI ⁽³⁾ , I2S2_SD ⁽³⁾ Remap: TIMER2_CH1, SPI0_MOSI, CAN1_RX
PB6	58	I/O	5VT	Default: PB6 Alternate: I2C0_SCL, TIMER3_CH0 ⁽³⁾ Remap: USART0_TX, CAN1_TX
PB7	59	I/O	5VT	Default: PB7 Alternate: I2C0_SDA, TIMER3_CH1 ⁽³⁾ Remap: USART0_RX
BOOT0	60	I		Default: BOOT0
PB8	61	I/O	5VT	Default: PB8 Alternate: TIMER3_CH2 ⁽³⁾ Remap: I2C0_SCL, CAN0_RX
PB9	62	I/O	5VT	Default: PB9 Alternate: TIMER3_CH3 ⁽³⁾ Remap: I2C0_SDA, CAN0_TX
VSS_3	63	P		Default: VSS_3
VDD_3	64	P		Default: VDD_3

Notes:

(1) Type: I = input, O = output, P = power.

(2) I/O Level: 5VT = 5 V tolerant.

(3) Functions are available in GD32VF103R8/B devices.

2.6.3. GD32VF103Cx LQFP48 pin definitions

Table 2-6. GD32VF103Cx LQFP48 pin definitions

GD32VF103Cx LQFP48				
Pin Name	Pins	Pin Type ⁽¹⁾	I/O Level ⁽²⁾	Functions description
VBAT	1	P		Default: VBAT
PC13-TAMPER-RTC	2	I/O		Default: PC13 Alternate: TAMPER-RTC
PC14-OSC32IN	3	I/O		Default: PC14 Alternate: OSC32IN
PC15-OSC32OUT	4	I/O		Default: PC15 Alternate: OSC32OUT
OSCIN-PD0	5	I		Default: OSCIN Remap: PD0
OSCOUT-PD1	6	O		Default: OSCOUT Remap: PD1
NRST	7	I/O		Default: NRST
VSSA	8	P		Default: VSSA
VDDA	9	P		Default: VDDA
PA0-WKUP	10	I/O		Default: PA0 Alternate: WKUP, USART1_CTS, ADC01_IN0, TIMER1_CH0_ETI, TIMER4_CH0 ⁽³⁾
PA1	11	I/O		Default: PA1 Alternate: USART1_RTS, ADC01_IN1, TIMER4_CH1 ⁽³⁾ , TIMER1_CH1
PA2	12	I/O		Default: PA2 Alternate: USART1_TX, TIMER4_CH2 ⁽³⁾ , ADC01_IN2, TIMER1_CH2
PA3	13	I/O		Default: PA3 Alternate: USART1_RX, TIMER4_CH3 ⁽³⁾ , ADC01_IN3, TIMER1_CH3
PA4	14	I/O		Default: PA4 Alternate: SPI0_NSS, USART1_CK, ADC01_IN4 DAC0_OUT0 Remap: SPI2_NSS ⁽³⁾ , I2S2_WS ⁽³⁾
PA5	15	I/O		Default: PA5 Alternate: SPI0_SCK, ADC01_IN5, DAC0_OUT1
PA6	16	I/O		Default: PA6 Alternate: SPI0_MISO, ADC01_IN6, TIMER2_CH0



GD32VF103Cx LQFP48				
Pin Name	Pins	Pin Type ⁽¹⁾	I/O Level ⁽²⁾	Functions description
				Remap: TIMER0_BRKIN
PA7	17	I/O		Default: PA7 Alternate: SPI0_MOSI, ADC01_IN7, TIMER2_CH1 Remap: TIMER0_CH0_ON
PB0	18	I/O		Default: PB0 Alternate: ADC01_IN8, TIMER2_CH2 Remap: TIMER0_CH1_ON
PB1	19	I/O		Default: PB1 Alternate: ADC01_IN9, TIMER2_CH3 Remap: TIMER0_CH2_ON
PB2	20	I/O	5VT	Default: PB2, BOOT1
PB10	21	I/O	5VT	Default: PB10 Alternate: I2C1_SCL ⁽³⁾ , USART2_TX ⁽³⁾ Remap: TIMER1_CH2
PB11	22	I/O	5VT	Default: PB11 Alternate: I2C1_SDA ⁽³⁾ , USART2_RX ⁽³⁾ Remap: TIMER1_CH3
VSS_1	23	P		Default: VSS_1
VDD_1	24	P		Default: VDD_1
PB12	25	I/O	5VT	Default: PB12 Alternate: SPI1_NSS ⁽³⁾ , I2S1_WS ⁽³⁾ , I2C1_SMBA ⁽³⁾ , USART2_CK ⁽³⁾ , TIMER0_BRKIN, CAN1_RX
PB13	26	I/O	5VT	Default: PB13 Alternate: SPI1_SCK ⁽³⁾ , I2S1_CK ⁽³⁾ , USART2_CTS ⁽³⁾ , TIMER0_CH0_ON, CAN1_TX
PB14	27	I/O	5VT	Default: PB14 Alternate: SPI1_MISO ⁽³⁾ , USART2_RTS ⁽³⁾ , TIMER0_CH1_ON
PB15	28	I/O	5VT	Default: PB15 Alternate: SPI1_MOSI ⁽³⁾ , TIMER0_CH2_ON, I2S1_SD ⁽³⁾
PA8	29	I/O	5VT	Default: PA8 Alternate: USART0_CK, TIMER0_CH0, CK_OUT0, USBFS_SOF
PA9	30	I/O	5VT	Default: PA9 Alternate: USART0_TX, TIMER0_CH1, USBFS_VBUS
PA10	31	I/O	5VT	Default: PA10 Alternate: USART0_RX, TIMER0_CH2, USBFS_ID
PA11	32	I/O	5VT	Default: PA11 Alternate: USART0_CTS, CAN0_RX, TIMER0_CH3,



GD32VF103Cx LQFP48				
Pin Name	Pins	Pin Type ⁽¹⁾	I/O Level ⁽²⁾	Functions description
				USBFS_DM
PA12	33	I/O	5VT	Default: PA12 Alternate: USART0_RTS, CAN0_TX, TIMER0_ETI, USBFS_DP
PA13	34	I/O	5VT	Default: JTMS Remap: PA13
VSS_2	35	P		Default: VSS_2
VDD_2	36	P		Default: VDD_2
PA14	37	I/O	5VT	Default: JTCK Remap: PA14
PA15	38	I/O	5VT	Default: JTDI Alternate: SPI2_NSS ⁽³⁾ , I2S2_WS ⁽³⁾ Remap: TIMER1_CH0_ETI, PA15, SPI0_NSS
PB3	39	I/O	5VT	Default: JTDO Alternate: SPI2_SCK ⁽³⁾ , I2S2_CK ⁽³⁾ Remap: PB3, TIMER1_CH1, SPI0_SCK
PB4	40	I/O	5VT	Default: NJTRST Alternate: SPI2_MISO ⁽³⁾ Remap: TIMER2_CH0, PB4, SPI0_MISO
PB5	41	I/O		Default: PB5 Alternate: I2C0_SMBA, SP12_MOSI ⁽³⁾ , I2S2_SD ⁽³⁾ Remap: TIMER2_CH1, SPI0_MOSI, CAN1_RX
PB6	42	I/O	5VT	Default: PB6 Alternate: I2C0_SCL, TIMER3_CH0 ⁽³⁾ Remap: USART0_TX, CAN1_TX
PB7	43	I/O	5VT	Default: PB7 Alternate: I2C0_SDA, TIMER3_CH1 ⁽³⁾ Remap: USART0_RX
BOOT0	44	I		Default: BOOT0
PB8	45	I/O	5VT	Default: PB8 Alternate: TIMER3_CH2 ⁽³⁾ Remap: I2C0_SCL, CAN0_RX
PB9	46	I/O	5VT	Default: PB9 Alternate: TIMER3_CH3 ⁽³⁾ Remap: I2C0_SDA, CAN0_TX
VSS_3	47	P		Default: VSS_3
VDD_3	48	P		Default: VDD_3

Notes:

(1) Type: I = input, O = output, P = power.



(2) I/O Level: 5VT = 5 V tolerant.

(3) Functions are available in GD32VF103C8/B devices.

2.6.4. GD32VF103Tx QFN36 pin definitions

Table 2-7. GD32VF103Tx QFN36 pin definitions

GD32VF103Tx QFN36				
Pin Name	Pins	Pin Type ⁽¹⁾	I/O Level ⁽²⁾	Functions description
VDD_3	1	P		Default: VDD_3
OSCIN-PD0	2	I		Default: OSCIN Remap: PD0
OSCOU-PD1	3	O		Default: OSCOUT Remap: PD1
NRST	4	I/O		Default: NRST
VSSA	5	P		Default: VSSA
VDDA	6	P		Default: VDDA
PA0-WKUP	7	I/O		Default: PA0 Alternate: WKUP, USART1_CTS, ADC01_IN0, TIMER1_CH0_ETI, TIMER4_CH0 ⁽³⁾
PA1	8	I/O		Default: PA1 Alternate: USART1_RTS, ADC01_IN1, TIMER1_CH1, TIMER4_CH1 ⁽³⁾
PA2	9	I/O		Default: PA2 Alternate: USART1_TX, ADC01_IN2, TIMER1_CH2, TIMER4_CH2 ⁽³⁾
PA3	10	I/O		Default: PA3 Alternate: USART1_RX, ADC01_IN3, TIMER1_CH3, TIMER4_CH3 ⁽³⁾
PA4	11	I/O		Default: PA4 Alternate: SPI0_NSS, USART1_CK, ADC01_IN4, DAC0_OUT0
PA5	12	I/O		Default: PA5 Alternate: SPI0_SCK, ADC01_IN5, DAC0_OUT1
PA6	13	I/O		Default: PA6 Alternate: SPI0_MISO, ADC01_IN6, TIMER2_CH0 Remap: TIMER0_BRKIN
PA7	14	I/O		Default: PA7 Alternate: SPI0_MOSI, ADC01_IN7, TIMER2_CH1 Remap: TIMER0_CH0_ON
PB0	15	I/O		Default: PB0 Alternate: ADC01_IN8, TIMER2_CH2 Remap: TIMER0_CH1_ON
PB1	16	I/O		Default: PB1



GD32VF103Tx QFN36				
Pin Name	Pins	Pin Type ⁽¹⁾	I/O Level ⁽²⁾	Functions description
				Alternate: ADC01_IN9, TIMER2_CH3 Remap: TIMER0_CH2_ON
PB2	17	I/O	5VT	Default: PB2,BOOT1
VSS_1	18	P		Default: VSS_1
VDD_1	19	P		Default: VDD_1
PA8	20	I/O	5VT	Default: PA8 Alternate: USART0_CK, TIMER0_CH0, CK_OUT0, USBFS_SOF
PA9	21	I/O	5VT	Default: PA9 Alternate: USART0_TX, TIMER0_CH1, USBFS_VBUS
PA10	22	I/O	5VT	Default: PA10 Alternate: USART0_RX, TIMER0_CH2, USBFS_ID
PA11	23	I/O	5VT	Default: PA11 Alternate: USART0_CTS, CAN0_RX, TIMER0_CH3, USBFS_DM
PA12	24	I/O	5VT	Default: PA12 Alternate: USART0_RTS, CAN0_TX, TIMER0_ETI, USBFS_DP
PA13	25	I/O	5VT	Default: JTMS Remap: PA13
VSS_2	26	P		Default: VSS_2
VDD_2	27	P		Default: VDD_2
PA14	28	I/O	5VT	Default: JTCK Remap: PA14
PA15	29	I/O	5VT	Default: JTDI Remap: TIMER1_CH0_ETI, PA15, SPI0_NSS
PB3	30	I/O	5VT	Default: JTDO Remap: PB3, TIMER1_CH1, SPI0_SCK
PB4	31	I/O	5VT	Default: NJTRST Remap: TIMER2_CH0, PB4, SPI0_MISO
PB5	32	I/O		Default: PB5 Alternate: I2C0_SMBA Remap: TIMER2_CH1, SPI0_MOSI, CAN1_RX
PB6	33	I/O	5VT	Default: PB6 Alternate: I2C0_SCL, TIMER3_CH0 ⁽³⁾ Remap: USART0_TX, CAN1_TX
PB7	34	I/O	5VT	Default: PB7 Alternate: I2C0_SDA, TIMER3_CH1 ⁽³⁾



GD32VF103Tx QFN36				
Pin Name	Pins	Pin Type ⁽¹⁾	I/O Level ⁽²⁾	Functions description
				Remap: USART0_RX
BOOT0	35	I		Default: BOOT0
VSS_3	36	P		Default: VSS_3

Notes:

- (1) Type: I = input, O = output, P = power.
- (2) I/O Level: 5VT = 5 V tolerant.
- (3) Functions are available in GD32VF103T8/B devices.

3. Functional description

3.1. System and memory architecture

The devices of GD32VF103 series are 32-bit general-purpose microcontrollers based on the 32bit RISC-V processor. The RISC-V processor includes three AHB buses known as I-Code, D-Code and System buses. All memory accesses of the RISC-V processor are executed on the three buses according to the different purposes and the target memory spaces. The memory organization uses a Harvard architecture, pre-defined memory map and up to 4 GB of memory space, making the system flexible and extendable.

3.2. On-chip memory

- Up to 128 Kbytes of Flash memory
- All memory region of the MCU executes instructions without waiting time
- 32 Kbytes of SRAM

The RISC-V processor is structured in Harvard architecture which can use separate buses to fetch instructions and load/store data. 128 Kbytes of inner Flash at most available for storing programs and data, and there is no waiting time when CPU executes instructions. The [Table 2-3. GD32VF103 memory map](#) shows the memory map of the GD32VF103 series of devices, including code, SRAM, peripheral, and other pre-defined regions.

3.3. Clock, reset and supply management

- Internal 8 MHz factory-trimmed RC and external 3 to 25 MHz crystal oscillator
- Internal 40 KHz RC calibrated oscillator and external 32.768 KHz crystal oscillator
- Integrated system clock PLL
- 2.6 to 3.6 V application supply and I/Os
- Supply Supervisor: POR (Power On Reset), PDR (Power Down Reset), and low voltage detector (LVD)

The Clock Control unit provides a range of frequencies and clock functions. These include an Internal 8M RC oscillator (IRC8M), a High Speed crystal oscillator (HXTAL), a Low Speed Internal 40K RC oscillator (IRC40K), a Low Speed crystal oscillator (LXTAL), a Phase Lock Loop (PLL), a HXTAL clock monitor, clock prescalers, clock multiplexers and clock gating circuitry. The frequency of AHB, APB2 and the APB1 domains can be configured by each prescaler. The maximum frequency of the AHB, APB2 and APB1 domains is 108 MHz/108 MHz/54 MHz. See [Figure 2-6. GD32VF103 clock tree](#) for details.

GD32VF103 Reset Control includes the control of three kinds of reset: power reset, system reset and backup domain reset. The system reset resets the processor core and peripheral

IP components except for the JTAG-DP controller and the Backup domain. Power-on reset (POR) and power-down reset (PDR) are always active, and ensures proper operation starting from/down to 2.6 V. The device remains in reset mode when V_{DD} is below a specified threshold. The embedded low voltage detector (LVD) monitors the power supply, compares it to the voltage threshold and generates an interrupt as a warning message for leading the MCU into security.

Power supply schemes:

- V_{DD} range: 2.6 to 3.6 V, external power supply for I/Os and the internal regulator. Provided externally through V_{DD} pins.
- V_{DDA} range: 2.6 to 3.6 V, external analog power supplies for ADC, reset blocks, RCs and PLL. V_{DDA} and V_{SSA} must be connected to V_{DD} and V_{SS} , respectively.
- V_{BAT} range: 1.8 to 3.6 V, power supply for RTC, external clock 32 KHz oscillator and backup registers (through power switch) when V_{DD} is not present.

3.4. Boot modes

At startup, boot pins are used to select one of three boot options:

- Boot from main flash memory (default)
- Boot from system memory
- Boot from on-chip SRAM

The boot loader is located in the internal boot ROM memory (system memory). It is used to reprogram the Flash memory by using USART0 (PA9 and PA10), USART1 (PD5 and PD6), USBFS in device mode (PA9, PA11 and PA12). It also can be used to transfer and update the Flash memory code, the data and the vector table sections.

3.5. Power saving modes

The MCU supports three kinds of power saving modes to achieve even lower power consumption. They are sleep mode, deep-sleep mode, and standby mode. These operating modes reduce the power consumption and allow the application to achieve the best balance between the CPU operating time, speed and power consumption.

- **Sleep mode**

In sleep mode, only clock of core is off. All peripherals continue to operate and any interrupt/event can wake up the system.

- **Deep-sleep mode**

In deep-sleep mode, all clocks in the 1.2V domain are off, and all of IRC8M, HXTAL and PLLs are disabled. Only the contents of SRAM and registers are retained. Any interrupt or wakeup event from EXTI lines can wake up the system from the deep-sleep mode including the 16 external lines, the RTC alarm/ time stamp/ tamper, the LVD output, USB Wakeup. When exiting the deep-sleep mode, the IRC8M is selected as the system clock.

- **Standby mode**

In standby mode, the whole 1.2V domain is power off, the LDO is shut down, and all of IRC8M, HXTAL and PLLs are disabled. The contents of SRAM and registers (except Backup registers) are lost. There are four wakeup sources for the Standby mode, including the external reset from NRST pin, the RTC alarm/ time stamp/ tamper, the FWDGT reset, and the rising edge on WKUP pin.

3.6. Analog to digital converter (ADC)

- 12-bit SAR ADC engine with up to 1MSPS conversion rate
- 12-bit, 10-bit, 8-bit or 6-bit configurable resolution
- Hardware oversampling ratio adjustable from 2 to 256x improves resolution to 16-bit
- Conversion range: V_{SSA} to V_{DDA} (2.6 to 3.6 V)
- Temperature sensor

Up to two 12-bit 1MSPS multi-channel ADCs are integrated in the device. Each is a total of up to 16 multiplexed external channels with 2 internal channels for temperature sensor and voltage reference measurement. An analog watchdog block can be used to detect the channels, which are required to remain within a specific threshold window. A configurable channel management block of analog inputs also can be used to perform conversions in single, continuous, scan or discontinuous mode to support more advanced usages.

The ADCs can be triggered from the events generated by the general level 0 timers (TIMERx=1,2,3) and the advanced timers (TIMER0) with internal connection. The temperature sensor has to generate a voltage that varies linearly with temperature. The conversion range is between $2.6\text{ V} < V_{DDA} < 3.6\text{ V}$. The temperature sensor is internally connected to the ADC_IN16 input channel which is used to convert the sensor output voltage into a digital value.

To ensure a high accuracy on ADC and DAC, the ADC/DAC independent external reference voltage should be connected to V_{REF+}/V_{REF-} pins. According to the different packages, V_{REF+} pin can be connected to V_{DDA} pin, or external reference voltage, V_{REF-} pin must be connected to V_{SSA} pin. The V_{REF+} pin is only available on no less than 100-pin packages, or else the V_{REF+} pin is not available and internally connected to V_{DDA} . The V_{REF-} pin is only available on no less than 100-pin packages, or else the V_{REF-} pin is not available and internally connected to V_{SSA} .

3.7. Digital to analog converter (DAC)

- One DAC with two channels can work independently or concurrently
- 8-bit or 12-bit mode in conjunction with the DMA controller

The two 12-bit buffered DAC channels are used to generate variable analog outputs. The DAC is designed with integrated resistor strings structure. The DAC channels can be triggered by the timer TRGO outputs or EXTI with DMA support. In dual DAC channel operation, conversions could be done independently or concurrently. The maximum output value of the DAC is V_{REFP} .

3.8. DMA

- 7 channel DMA0 controller and 5 channel DMA1 controller
- Peripherals supported: TIMERS, ADC, SPIs, I2Cs, USARTs, DAC, I2S

The direct memory access (DMA) controllers provide a hardware method of transferring data between peripherals and/or memory without intervention from the CPU, thereby freeing up bandwidth for other system functions. Three types of access method are supported: peripheral to memory, memory to peripheral, memory to memory

Each channel is connected to fixed hardware DMA requests. The priorities of DMA channel requests are determined by software configuration and hardware channel number. Transfer size of source and destination are independent and configurable.

3.9. General-purpose inputs/outputs (GPIOs)

- Up to 80 fast GPIOs, all mappable on 16 external interrupt lines
- Analog input/output configurable
- Alternate function input/output configurable

There are up to 80 general purpose I/O pins (GPIO), named PA0 ~ PA15, PB0 ~ PB15, PC0 ~ PC15, PD0 ~ PD15, PE0 ~ PE15 for the device to implement logic input/output functions. Each GPIO port has related control and configuration registers to satisfy the requirements of specific applications. The external interrupt on the GPIO pins of the device have related control and configuration registers in the Interrupt/event Controller Unit (EXTI). The GPIO

ports are pin-shared with other alternative functions (AFs) to obtain maximum flexibility on the package pins. The GPIO pins can be used as alternative functional pins by configuring the corresponding registers regardless of the AF input or output pins. Each of the GPIO pins can be configured by software as output (push-pull or open-drain), input, peripheral alternate function or analog mode. Each GPIO pin can be configured as pull-up, pull-down or no pull-up/pull-down. All GPIOs are high-current capable except for analog mode.

3.10. Timers and PWM generation

- Up to one 16-bit advanced timer (TIMER0), four 16-bit general timers(TIMERx=1,2,3,4), and two 16-bit basic timer (TIMER5 & TIMER6)
- Up to 4 independent channels of PWM, output compare or input capture for each general timer and external trigger input
- 16-bit, motor control PWM advanced timer with programmable dead-time generation for output match
- Encoder interface controller with two inputs using quadrature decoder
- 64-bit SysTick timer up counter
- 2 watchdog timers (Free watchdog timer and window watchdog timer)

The advanced timer (TIMER0) can be seen as a three-phase PWM multiplexed on 6 channels. It has complementary PWM outputs with programmable dead-time generation. It can also be used as a complete general timer. The 4 independent channels can be used for

- Input capture
- Output compare
- PWM generation (edge-aligned or center-aligned counting modes)
- Single pulse mode output

If configured as a general 16-bit timer, it can be synchronized with external signals or to interconnect with other general timers together which have the same architecture and features.

The general timer, known as TIMERx=1,2,3,4 can be used for a variety of purposes including general time, input signal pulse width measurement or output waveform generation such as a single pulse generation or PWM output, up to 4 independent channels for input capture/output compare. The general timer also supports an encoder interface with two inputs using quadrature decoder.

The basic timer, known as TIMER5 and TIMER6 are mainly used for DAC trigger generation. They can also be used as a simple 16-bit time base.

The GD32VF103 have two watchdog peripherals, free watchdog timer and window watchdog timer. They offer a combination of high safety level, flexibility of use and timing accuracy.

The free watchdog timer includes a 12-bit down-counting counter and a 3-bit prescaler, it is clocked from an independent 40 KHz internal RC and as it operates independently of the

main clock, it can operate in deep-sleep and standby modes. It can be used either as a watchdog to reset the device when a problem occurs, or as a free-running timer for application timeout management.

The window watchdog timer is based on a 7-bit down counter that can be set as free-running. It can be used as a watchdog to reset the device when a problem occurs. It is clocked from the main clock. It has an early wakeup interrupt capability and the counter can be frozen in debug mode.

The SysTick timer is dedicated for OS, but could also be used as a standard up counter. The features are shown below:

- A 64-bit up counter
- Maskable system interrupt generation when the counter and comparison values are equal
- Programmable clock source

3.11. Real time clock (RTC)

- 32-bit up-counter with a programmable 20-bit prescaler
- Alarm function
- Interrupt and wake-up event

The real time clock is an independent timer which provides a set of continuously running counters which can be used with suitable software to provide a clock calendar function, and provides an alarm interrupt and an expected interrupt. The RTC features a 32-bit programmable counter for long-term measurement using the compare register to generate an alarm. A 20-bit prescaler is used for the time base clock and is by default configured to generate a time base of 1 second from a clock at 32.768 KHz from external crystal oscillator.

3.12. Inter-integrated circuit (I2C)

- Up to two I2C bus interfaces can support both master and slave mode with a frequency up to 400 KHz
- Provide arbitration function, optional PEC (packet error checking) generation and checking
- Supports 7-bit and 10-bit addressing mode and general call addressing mode

The I2C interface is an internal circuit allowing communication with an external I2C interface which is an industry standard two line serial interface used for connection to external hardware. These two serial lines are known as a serial data line (SDA) and a serial clock line (SCL). The I2C module provides transfer rate of up to 100 KHz in standard mode, up to 400 KHz in the fast mode and up to 1 MHz in the fast mode plus. The I2C module also has an arbitration detect function to prevent the situation where more than one master attempts to



transmit data to the I2C bus at the same time. A CRC-8 calculator is also provided in I2C interface to perform packet error checking for I2C data.

3.13. Serial peripheral interface (SPI)

- Up to three SPI interfaces
- Support both master and slave mode
- Hardware CRC calculation and transmit automatic CRC error checking

The SPI interface uses 4 pins, among which are the serial data input and output lines (MISO & MOSI), the clock line (SCK) and the slave select line (NSS). Both SPIs can be served by the DMA controller. The SPI interface may be used for a variety of purposes, including simplex synchronous transfers on two lines with a possible bidirectional data line or reliable communication using CRC checking.

3.14. Universal synchronous asynchronous receiver transmitter (USART)

- Maximum speed up to 6.75Mbit/s for USART0
- Maximum speed up to 3.375Mbit/s for USART1, USART2, UART3 and UART4
- Supports both asynchronous and clocked synchronous serial communication modes
- IrDA SIR encoder and decoder support
- LIN break generation and detection
- USARTs support ISO 7816-3 compliant smart card interface

The USART (USART0, USART1 and USART2) are used to translate data between parallel and serial interfaces, provides a flexible full duplex data exchange using synchronous or asynchronous transfer. It is also commonly used for RS-232 standard communication. The USART includes a programmable baud rate generator which is capable of dividing the system clock to produce a dedicated clock for the USART transmitter and receiver. The USART also supports DMA function for high speed data communication except UART4.

3.15. Inter-IC sound (I2S)

- Two I2S bus Interfaces with sampling frequency from 8 KHz to 192 KHz
- Support either master or slave mode

The Inter-IC sound (I2S) bus provides a standard communication interface for digital audio applications by 3-wire serial lines. GD32VF103 contain two I2S-bus interfaces that can be operated with 16/32 bit resolution in master or slave mode, pin multiplexed with SPI1 and SPI2. The audio sampling frequency from 8 KHz to 192 KHz is supported with less than 0.5% accuracy error.

3.16. Universal serial bus full-speed (USBFS)

- One USB device/host/OTG full-speed Interface with frequency up to 12 Mbit/s
- Internal main PLL for USB CLK compliantly

The Universal Serial Bus (USB) is a 4-wire bus with 4 bidirectional endpoints. The device controller enables 12 Mbit/s data exchange with integrated transceivers in device/host/OTG mode. Full-speed peripheral is compliant with the USB 2.0 specification. Transaction formatting is performed by the hardware, including CRC generation and checking. The status of a completed USB transfer or error condition is indicated by status registers. An interrupt is also generated if enabled. The dedicated 48 MHz clock is generated from the internal main PLL (the clock source must use a HXTAL crystal oscillator) and the operating frequency divided from APB1 should be 12 MHz above.

3.17. Controller area network (CAN)

- Two CAN2.0B interface with communication frequency up to 1 Mbit/s
- Internal main PLL for USB CLK compliantly

Controller area network (CAN) is a method for enabling serial communication in field bus. The CAN protocol has been used extensively in industrial automation and automotive applications. It can receive and transmit standard frames with 11-bit identifiers as well as extended frames with 29-bit identifiers. Each CAN has three mailboxes for transmission and two FIFOs of three message deep for reception. It also provides 28 scalable/configurable identifier filter banks for selecting the incoming messages needed and discarding the others.

3.18. External memory controller (EXMC)

- Supported external memory: SRAM, PSRAM, ROM and NOR-Flash
- Up to 16-bit data bus
- Support to interface with Motorola 6800 and Intel 8080 type LCD directly

External memory controller (EXMC) is an abbreviation of external memory controller. It has one bank for external device support. The EXMC also can be configured to interface with the most common LCD module of Motorola 6800 and Intel 8080 series and reduce the system cost and complexity.

3.19. Debug mode

- Support standard JTAG debugging interface and mature interactive debugging tool GDB
- Support up to four hardware breakpoints



The RISC-V Core does not support trace debugging. Hardware breakpoints are mainly used to set breakpoints at read-only sections (such as Flash).

3.20. Package and operation temperature

- LQFP100 (GD32VF103Vx), LQFP64 (GD32VF103Rx), LQFP48 (GD32VF103Cx), QFN36 (GD32VF103Tx)
- Operation temperature range: -40°C to +85°C (industrial level)

4. Electrical characteristics

4.1. Absolute maximum ratings

The maximum ratings are the limits to which the device can be subjected without permanently damaging the device. Note that the device is not guaranteed to operate properly beyond the maximum ratings. Exposure to the absolute maximum rating conditions for extended periods may affect device reliability.

Table 4-1. Absolute maximum ratings⁽¹⁾⁽⁴⁾

Symbol	Parameter	Min	Max	Unit
V _{DD}	External voltage range ⁽²⁾	V _{SS} - 0.3	V _{SS} + 3.6	V
V _{DDA}	External analog supply voltage	V _{SSA} - 0.3	V _{SSA} + 3.6	V
V _{BAT}	External battery supply voltage	V _{SS} - 0.3	V _{SS} + 3.6	V
V _{IN}	Input voltage on 5V tolerant pin ⁽³⁾	V _{SS} - 0.3	V _{DD} + 3.6	V
	Input voltage on other I/O	V _{SS} - 0.3	3.6	V
ΔV _{DDX}	Variations between different VDD power pins	—	50	mV
V _{SSX} - V _{SS}	Variations between different ground pins	—	50	mV
I _{IO}	Maximum current for GPIO pins	—	±25	mA
T _A	Operating temperature range	-40	+85	°C
P _D	Power dissipation at T _A = 85°C of LQFP100	—	697	mW
	Power dissipation at T _A = 85°C of LQFP64	—	647	
	Power dissipation at T _A = 85°C of LQFP48	—	621	
	Power dissipation at T _A = 85°C of QFN36	—	926	
T _{STG}	Storage temperature range	-65	+150	°C
T _J	Maximum junction temperature	—	125	°C

(1) Guaranteed by design, not tested in production.

(2) All main power and ground pins should be connected to an external power source within the allowable range.

(3) V_{IN} maximum value cannot exceed 5.5 V.

(4) It is recommended that V_{DD} and V_{DDA} are powered by the same source. The maximum difference between V_{DD} and V_{DDA} does not exceed 300 mV during power-up and operation.

4.2. Operating conditions characteristics

Table 4-2. DC operating conditions

Symbol	Parameter	Conditions	Min ⁽¹⁾	Typ	Max ⁽¹⁾	Unit
V _{DD}	Supply voltage	—	2.6	3.3	3.6	V
V _{DDA}	Analog supply voltage	Same as V _{DD}	2.6	3.3	3.6	V
V _{BAT}	Battery supply voltage	—	1.8 ⁽²⁾	—	3.6	V

(1) Based on characterization, not tested in production.

(2) In the application which V_{BAT} supply the backup domains, if the V_{BAT} voltage drops below the minimum value, when V_{DD} is powered on again, it is necessary to refresh the registers of backup domains and enable LXTAL again.

Figure 4-1. Recommended power supply decoupling capacitors⁽¹⁾⁽²⁾

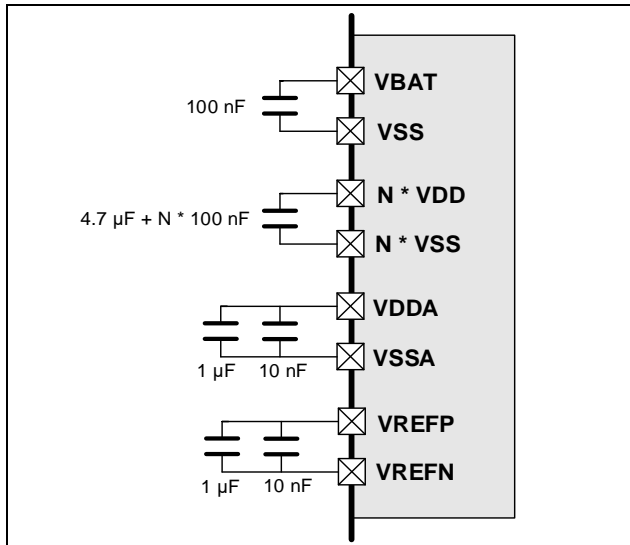

- (1) The VREFP and VREFN pins are only available on no less than 100-pin packages, or else the VREFP and VREFN pins are not available and internally connected to VDDA and VSSA pins. More details refer to **AN091 GD32VF103 Hardware Development Guide**.
- (2) All decoupling capacitors need to be as close as possible to the pins on the PCB board.

Table 4-3. Clock frequency⁽¹⁾

Symbol	Parameter	Conditions	Min	Max	Unit
f_{HCLK}	AHB clock frequency	—	—	108	MHz
f_{APB1}	APB1 clock frequency	—	—	54	MHz
f_{APB2}	APB2 clock frequency	—	—	108	MHz

- (1) Guaranteed by design, not tested in production.

Table 4-4. Operating conditions at Power up/ Power down⁽¹⁾

Symbol	Parameter	Conditions	Min	Max	Unit
t_{VDD}	V_{DD} rise time rate	—	0	∞	$\mu\text{s}/\text{V}$
	V_{DD} fall time rate		20	∞	

- (1) Guaranteed by design, not tested in production.

Table 4-5. Start-up timings of Operating conditions⁽¹⁾⁽²⁾⁽³⁾

Symbol	Parameter	Conditions	Typ	Unit
$t_{\text{start-up}}$	Start-up time	Clock source from HXTAL	132	ms
		Clock source from IRC8M	132	

- (1) Based on characterization, not tested in production.
- (2) After power-up, the start-up time is the time between the rising edge of NRST high and the main function.
- (3) PLL is off.

Table 4-6. Power saving mode wakeup timings characteristics⁽¹⁾⁽²⁾

Symbol	Parameter	Typ	Unit
t_{Sleep}	Wakeup from Sleep mode	4.5	μs
$t_{\text{Deep-sleep}}$	Wakeup from Deep-sleep mode (LDO On)	6.0	
	Wakeup from Deep-sleep mode (LDO in low power mode)	6.0	



Symbol	Parameter	Typ	Unit
$t_{Standby}$	Wakeup from Standby mode	118.8	ms

- (1) Based on characterization, not tested in production.
- (2) The wakeup time is measured from the wakeup event to the point at which the application code reads the first instruction under the below conditions: $V_{DD} = V_{DDA} = 3.3\text{ V}$, IRC8M = System clock = 8 MHz.

4.3. Power consumption

The power measurements specified in the tables represent that code with data executing from on-chip Flash with the following specifications.

Table 4-7. Power consumption characteristics⁽²⁾⁽³⁾⁽⁴⁾⁽⁵⁾⁽⁶⁾

Symbol	Parameter	Conditions	Min	Typ ⁽¹⁾	Max	Unit
$I_{DD}+I_{DDA}$	Supply current (Run mode)	$V_{DD} = V_{DDA} = 3.3\text{ V}$, HXTAL = 25 MHz, System clock = 108 MHz, All peripherals enabled	—	35.00	—	mA
		$V_{DD} = V_{DDA} = 3.3\text{ V}$, HXTAL = 25 MHz, System clock = 108 MHz, All peripherals disabled	—	20.05	—	mA
		$V_{DD} = V_{DDA} = 3.3\text{ V}$, HXTAL = 25 MHz, System clock = 96 MHz, All peripherals enabled	—	32.30	—	mA
		$V_{DD} = V_{DDA} = 3.3\text{ V}$, HXTAL = 25 MHz, System clock = 96 MHz, All peripherals disabled	—	18.90	—	mA
		$V_{DD} = V_{DDA} = 3.3\text{ V}$, HXTAL = 25 MHz, System clock = 72 MHz, All peripherals enabled	—	23.50	—	mA
		$V_{DD} = V_{DDA} = 3.3\text{ V}$, HXTAL = 25 MHz, System clock = 72 MHz, All peripherals disabled	—	13.40	—	mA
		$V_{DD} = V_{DDA} = 3.3\text{ V}$, HXTAL = 25 MHz, System clock = 48 MHz, All peripherals enabled	—	16.60	—	mA
		$V_{DD} = V_{DDA} = 3.3\text{ V}$, HXTAL = 25 MHz, System clock = 48 MHz, All peripherals disabled	—	9.90	—	mA
		$V_{DD} = V_{DDA} = 3.3\text{ V}$, HXTAL = 25 MHz, System clock = 36 MHz, All peripherals enabled	—	13.10	—	mA
		$V_{DD} = V_{DDA} = 3.3\text{ V}$, HXTAL = 25 MHz, System clock = 36 MHz, All peripherals disabled	—	8.10	—	mA



Symbol	Parameter	Conditions	Min	Typ ⁽¹⁾	Max	Unit
		V _{DD} = V _{DDA} = 3.3 V, HXTAL = 25 MHz, System clock = 24 MHz, All peripherals enabled	—	9.80	—	mA
		V _{DD} = V _{DDA} = 3.3 V, HXTAL = 25 MHz, System clock = 24 MHz, All peripherals disabled	—	6.50	—	mA
		V _{DD} = V _{DDA} = 3.3 V, HXTAL = 25 MHz, System clock = 16 MHz, All peripherals enabled	—	7.60	—	mA
		V _{DD} = V _{DDA} = 3.3 V, HXTAL = 25 MHz, System clock = 16 MHz, All peripherals disabled	—	5.30	—	mA
		V _{DD} = V _{DDA} = 3.3 V, HXTAL = 25 MHz, System clock = 8 MHz, All peripherals enabled	—	5.30	—	mA
		V _{DD} = V _{DDA} = 3.3 V, HXTAL = 25 MHz, System clock = 8 MHz, All peripherals disabled	—	4.10	—	mA
		V _{DD} = V _{DDA} = 3.3 V, HXTAL = 4 MHz, System clock = 4 MHz, All peripherals enabled	—	1.80	—	mA
		V _{DD} = V _{DDA} = 3.3 V, HXTAL = 4 MHz, System clock = 4 MHz, All peripherals disabled	—	1.30	—	mA
		V _{DD} = V _{DDA} = 3.3 V, HXTAL = 2 MHz, System clock = 2 MHz, All peripherals enabled	—	1.30	—	mA
		V _{DD} = V _{DDA} = 3.3 V, HXTAL = 2 MHz, System clock = 2 MHz, All peripherals disabled	—	1.00	—	mA
	Supply current (Sleep mode)	V _{DD} = V _{DDA} = 3.3 V, HXTAL = 25 MHz, System Clock = 108 MHz, CPU clock off, All peripherals enabled	—	26.20	—	mA
		V _{DD} = V _{DDA} = 3.3 V, HXTAL = 25 MHz, System Clock = 108 MHz, CPU clock off, All peripherals disabled	—	11.35	—	mA
		V _{DD} = V _{DDA} = 3.3 V, HXTAL = 25 MHz, System Clock = 96 MHz, CPU clock off, All peripherals enabled	—	24.10	—	mA
		V _{DD} = V _{DDA} = 3.3 V, HXTAL = 25 MHz, System Clock = 96 MHz, CPU clock off, All peripherals disabled	—	10.70	—	mA



Symbol	Parameter	Conditions	Min	Typ ⁽¹⁾	Max	Unit
		peripherals disabled				
		V _{DD} = V _{DDA} = 3.3 V, HXTAL = 25 MHz, System Clock = 72 MHz, CPU clock off, All peripherals enabled	—	18.70	—	mA
		V _{DD} = V _{DDA} = 3.3 V, HXTAL = 25 MHz, System Clock = 72 MHz, CPU clock off, All peripherals disabled	—	8.70	—	mA
		V _{DD} = V _{DDA} = 3.3 V, HXTAL = 25 MHz, System Clock = 48 MHz, CPU clock off, All peripherals enabled	—	13.40	—	mA
		V _{DD} = V _{DDA} = 3.3 V, HXTAL = 25 MHz, System Clock = 48 MHz, CPU clock off, All peripherals disabled	—	6.70	—	mA
		V _{DD} = V _{DDA} = 3.3 V, HXTAL = 25 MHz, System Clock = 36 MHz, CPU clock off, All peripherals enabled	—	1.80	—	mA
		V _{DD} = V _{DDA} = 3.3 V, HXTAL = 25 MHz, System Clock = 36 MHz, CPU clock off, All peripherals disabled	—	5.70	—	mA
		V _{DD} = V _{DDA} = 3.3 V, HXTAL = 25 MHz, System Clock = 24 MHz, CPU clock off, All peripherals enabled	—	8.30	—	mA
		V _{DD} = V _{DDA} = 3.3 V, HXTAL = 25 MHz, System Clock = 24 MHz, CPU clock off, All peripherals disabled	—	4.90	—	mA
		V _{DD} = V _{DDA} = 3.3 V, HXTAL = 25 MHz, System Clock = 16 MHz, CPU clock off, All peripherals enabled	—	6.50	—	mA
		V _{DD} = V _{DDA} = 3.3 V, HXTAL = 25 MHz, System Clock = 16 MHz, CPU clock off, All peripherals disabled	—	4.30	—	mA
		V _{DD} = V _{DDA} = 3.3 V, HXTAL = 25 MHz, System Clock = 8 MHz, CPU clock off, All peripherals enabled	—	4.70	—	mA
		V _{DD} = V _{DDA} = 3.3 V, HXTAL = 25 MHz, System Clock = 8 MHz, CPU clock off, All peripherals disabled	—	3.60	—	mA
		V _{DD} = V _{DDA} = 3.3 V, HXTAL = 4 MHz, System Clock = 4 MHz, CPU clock off, All peripherals enabled	—	1.40	—	mA
		V _{DD} = V _{DDA} = 3.3 V, HXTAL = 4 MHz,	—	0.90	—	mA



Symbol	Parameter	Conditions	Min	Typ ⁽¹⁾	Max	Unit
		System Clock = 4 MHz, CPU clock off, All peripherals disabled				
		V _{DD} = V _{DDA} = 3.3 V, HXTAL = 2 MHz, System Clock = 2 MHz, CPU clock off, All peripherals enabled	—	1.00	—	mA
		V _{DD} = V _{DDA} = 3.3 V, HXTAL = 2 MHz, System Clock = 2 MHz, CPU clock off, All peripherals disabled	—	0.70	—	mA
	Supply current (Deep-Sleep mode)	V _{DD} = V _{DDA} = 3.3 V, LDO in normal power and normal driver mode, IRC40K off, RTC off, All GPIOs analog mode	—	460.0 0	2200	μA
		V _{DD} = V _{DDA} = 3.3 V, LDO in normal power and low driver mode, IRC40K off, RTC off, All GPIOs analog mode	—	427.5 0	2200	μA
	Supply current (Standby mode)	V _{DD} = V _{DDA} = 3.3 V, LDO off, LXTAL off, IRC40K on, RTC on	—	7.62	22	μA
		V _{DD} = V _{DDA} = 3.3 V, LDO off, LXTAL off, IRC40K on, RTC off	—	7.49	22	μA
		V _{DD} = V _{DDA} = 3.3 V, LDO off, LXTAL off, IRC40K off, RTC off	—	6.32	22	μA
	I _{BAT}	Battery supply current (Backup mode)	V _{DD} off, V _{DDA} off, V _{BAT} = 3.6 V, LXTAL on with external crystal, RTC on	—	2.18	—
V _{DD} off, V _{DDA} off, V _{BAT} = 3.3 V, LXTAL on with external crystal, RTC on			—	2.10	—	μA
V _{DD} off, V _{DDA} off, V _{BAT} = 2.6 V, LXTAL on with external crystal, RTC on			—	1.97	—	μA

- (1) Based on characterization, not tested in production.
- (2) Unless otherwise specified, all values given for T_A = 25 °C and test result is mean value.
- (3) When System Clock is less than 4 MHz, an external source is used, and the HXTAL bypass function is needed, no PLL.
- (4) When System Clock is greater than 8 MHz, a crystal 8 MHz is used, and the HXTAL bypass function is closed, using PLL.
- (5) When analog peripheral blocks such as ADCs, DACs, HXTAL, LXTAL, IRC8M, or IRC40K are ON, an additional power consumption should be considered.
- (6) All GPIOs are configured as analog mode except standby mode.

Figure 4-2. Typical supply current consumption in Run mode

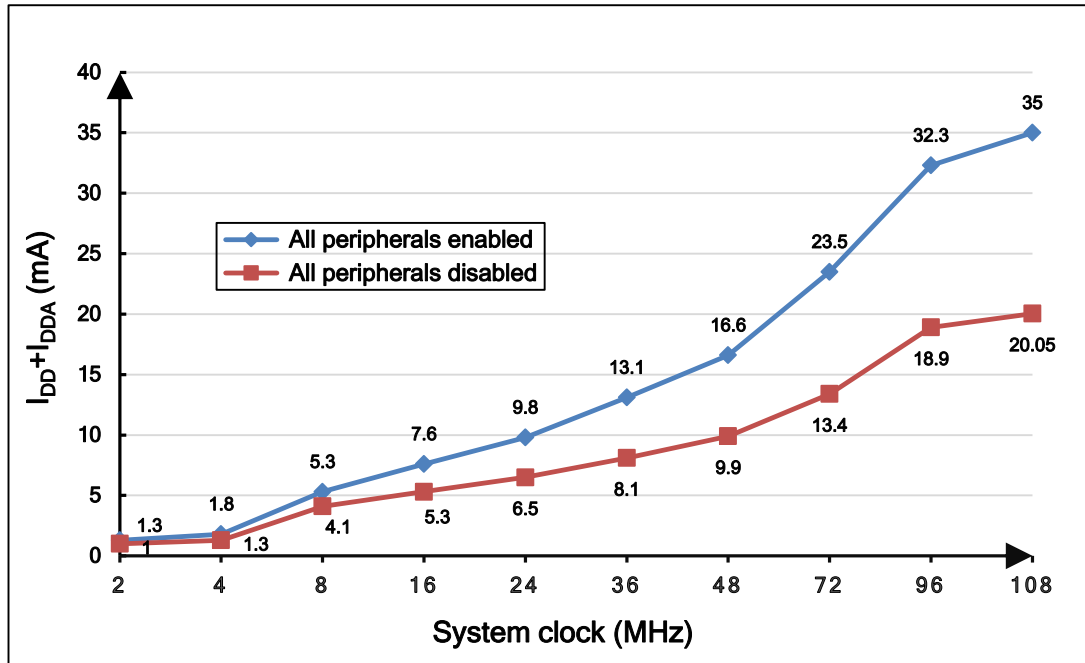
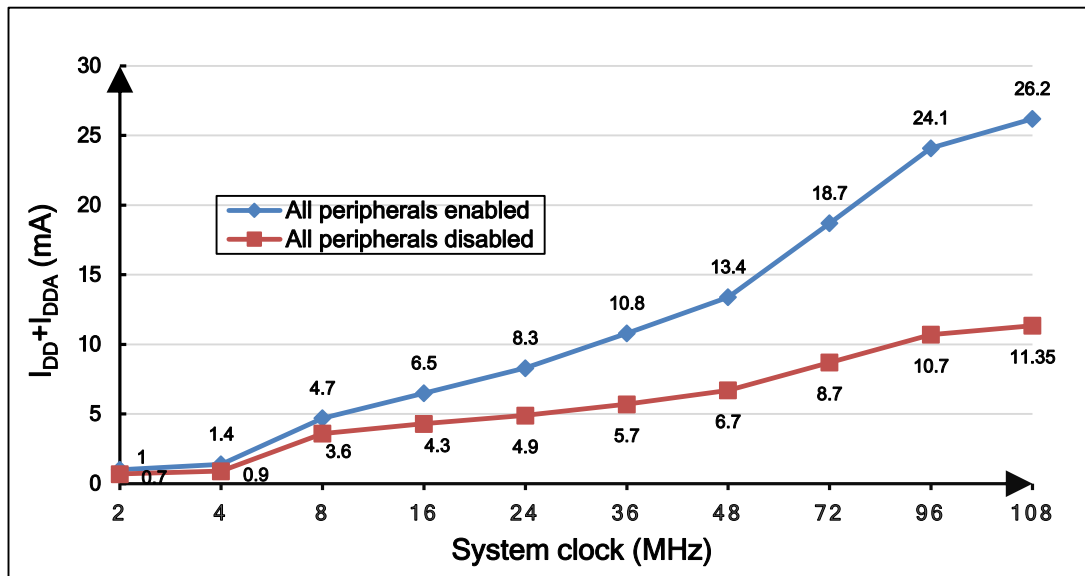

Figure 4-3. Typical supply current consumption in Sleep mode



4.4. EMC characteristics

EMS (electromagnetic susceptibility) includes ESD (Electrostatic discharge, positive and negative) and FTB (Burst of Fast Transient voltage, positive and negative) testing result is given in the [Table 4-8. EMS characteristics](#), based on the EMS levels and classes compliant with IEC 61000 series standard.

Table 4-8. EMS characteristics⁽¹⁾

Symbol	Parameter	Conditions	Level/Class
V _{ESD}	Voltage applied to all device pins to induce a functional disturbance	V _{DD} = 3.3 V, T _A = 25 °C LQFP100, f _{HCLK} = 108 MHz conforms to IEC 61000-4-2	3A
V _{FTB}	Fast transient voltage burst applied to induce a functional disturbance through 100 pF on VDD and VSS pins	V _{DD} = 3.3 V, T _A = 25 °C LQFP100, f _{HCLK} = 108 MHz conforms to IEC 61000-4-2	4A

(1) Based on characterization, not tested in production

4.5. Power supply supervisor characteristics

Table 4-9. Power supply supervisor characteristics

Symbol	Parameter	Conditions	Min	Typ	Max	Unit
V _{LVD} ⁽¹⁾	Low voltage Detector level selection	LVDT<2:0> = 000(rising edge)	—	2.18	—	V
		LVDT<2:0> = 000(falling edge)	—	2.08	—	
		LVDT<2:0> = 001(rising edge)	—	2.29	—	
		LVDT<2:0> = 001(falling edge)	—	2.19	—	
		LVDT<2:0> = 010(rising edge)	—	2.38	—	
		LVDT<2:0> = 010(falling edge)	—	2.28	—	
		LVDT<2:0> = 011(rising edge)	—	2.49	—	
		LVDT<2:0> = 011(falling edge)	—	2.38	—	
		LVDT<2:0> = 100(rising edge)	—	2.58	—	
		LVDT<2:0> = 100(falling edge)	—	2.48	—	
		LVDT<2:0> = 101(rising edge)	—	2.68	—	
		LVDT<2:0> = 101(falling edge)	—	2.58	—	
		LVDT<2:0> = 110(rising edge)	—	2.78	—	
		LVDT<2:0> = 110(falling edge)	—	2.68	—	
LVDT<2:0> = 111(rising edge)	—	2.88	—			
LVDT<2:0> = 111(falling edge)	—	2.78	—			
V _{LVDhyst} ⁽²⁾	LVD hysteresis	—	—	100	—	mV
V _{POR} ⁽¹⁾	Power on reset threshold	—	—	2.44	—	V
V _{PDR} ⁽¹⁾	Power down reset	—	—	1.86	—	V



Symbol	Parameter	Conditions	Min	Typ	Max	Unit
	threshold					
$V_{PDRhyst}^{(2)}$	PDR hysteresis		—	600	—	mV
$t_{RSTTEMPO}^{(2)}$	Reset temporization		—	2	—	ms

(1) Based on characterization, not tested in production

(2) Guaranteed by design, not tested in production

4.6. Electrical sensitivity

The device is strained in order to determine its performance in terms of electrical sensitivity. Electrostatic discharges (ESD) are applied directly to the pins of the sample. Static latch-up (LU) test is based on the two measurement methods.

Table 4-10. ESD characteristics⁽¹⁾

Symbol	Parameter	Conditions	Min	Typ	Max	Unit
$V_{ESD(HBM)}$	Electrostatic discharge voltage (human body model)	$T_A = 25\text{ °C}$; JESD22-A114	—	—	5000	V
$V_{ESD(CDM)}$	Electrostatic discharge voltage (charge device model)	$T_A = 25\text{ °C}$; JESD22-C101	—	—	500	V

(1) Based on characterization, not tested in production.

Table 4-11. Static latch-up characteristics⁽¹⁾

Symbol	Parameter	Conditions	Min	Typ	Max	Unit
LU	I-test	$T_A = 25\text{ °C}$; JESD78	—	—	± 200	mA
	V_{supply} over voltage		—	—	5.4	V

(1) Based on characterization, not tested in production.

4.7. External clock characteristics

Table 4-12. High speed external clock (HXTAL) generated from a crystal/ceramic characteristics

Symbol	Parameter	Conditions	Min	Typ	Max	Unit
$f_{HXTAL}^{(1)}$	Crystal or ceramic frequency	$2.6\text{ V} \leq V_{DD} \leq 3.6\text{ V}$	3	8	25	MHz
$R_F^{(2)}$	Feedback resistor	$V_{DD} = 3.3\text{ V}$	—	400	—	k Ω
$C_{HXTAL}^{(2)(3)}$	Recommended matching capacitance on OSCIN and OSCOUT	—	—	20	30	pF
$D_{ucy(HXTAL)}^{(2)}$	Crystal or ceramic duty cycle	—	48	50	52	%
$g_m^{(2)}$	Oscillator transconductance	Startup	—	35	—	mA/V
$I_{DDHXTAL}^{(1)}$	Crystal or ceramic operating	$V_{DD} = 3.3\text{ V}$, $f_{HCLK} =$	—	1.4	—	mA



Symbol	Parameter	Conditions	Min	Typ	Max	Unit
	current	$f_{IRC8M} = 8 \text{ MHz}$ $T_A = 25 \text{ }^\circ\text{C}$				
$t_{SUHXTAL}^{(1)}$	Crystal or ceramic startup time	$V_{DD} = 3.3 \text{ V}$, $f_{HCLK} =$ $f_{IRC8M} = 8 \text{ MHz}$ $T_A = 25 \text{ }^\circ\text{C}$	—	1.8	—	ms

- (1) Based on characterization, not tested in production.
- (2) Guaranteed by design, not tested in production.
- (3) $C_{HXTAL1} = C_{HXTAL2} = 2*(C_{LOAD} - C_S)$, For C_{HXTAL1} and C_{HXTAL2} , it is recommended matching capacitance on OSCIN and OSCOUT. For C_{LOAD} , it is crystal/ceramic load capacitance, provided by the crystal or ceramic manufacturer. For C_S , it is PCB and MCU pin stray capacitance.

Table 4-13. High speed external clock characteristics (HXTAL in bypass mode)

Symbol	Parameter	Conditions	Min	Typ	Max	Unit
$f_{HXTAL_ext}^{(1)}$	External clock source or oscillator frequency	$V_{DD} = 3.3 \text{ V}$	1	—	50	MHz
$V_{HXTALH}^{(2)}$	OSCIN input pin high level voltage	$V_{DD} = 3.3 \text{ V}$	$0.7 V_{DD}$	—	V_{DD}	V
$V_{HXTALL}^{(2)}$	OSCIN input pin low level voltage		V_{SS}	—	$0.3 V_{DD}$	V
$t_{H/L(HXTAL)}^{(2)}$	OSCIN high or low time	—	5	—	—	ns
$t_{R/F(HXTAL)}^{(2)}$	OSCIN rise or fall time	—	—	—	10	ns
$C_{IN}^{(2)}$	OSCIN input capacitance	—	—	5	—	pF
$D_{ucy(HXTAL)}^{(2)}$	Duty cycle	—	40	—	60	%

- (1) Based on characterization, not tested in production.
- (2) Guaranteed by design, not tested in production.

Table 4-14. Low speed external clock (LXTAL) generated from a crystal/ceramic characteristics

Symbol	Parameter	Conditions	Min	Typ	Max	Unit
$f_{LXTAL}^{(1)}$	Crystal or ceramic frequency	$V_{DD} = 3.3 \text{ V}$	—	32.768	—	kHz
$C_{LXTAL}^{(2)(3)}$	Recommended matching capacitance on OSC32IN and OSC32OUT	—	—	10	20	pF
$D_{ucy(LXTAL)}^{(2)}$	Crystal or ceramic duty cycle	—	48	50	52	%
$g_m^{(2)}$	Oscillator transconductance	—	—	11	—	$\mu\text{A/V}$
$I_{DDLXTAL}^{(1)}$	Crystal or ceramic operating current	—	—	1.97	—	μA
$t_{SULXTAL}^{(1)(4)}$	Crystal or ceramic startup time	—	—	1.8	—	s

- (1) Based on characterization, not tested in production.
- (2) Guaranteed by design, not tested in production.
- (3) $C_{LXTAL1} = C_{LXTAL2} = 2*(C_{LOAD} - C_S)$, For C_{LXTAL1} and C_{LXTAL2} , it is recommended matching capacitance on OSC32IN and OSC32OUT. For C_{LOAD} , it is crystal/ceramic load capacitance, provided by the crystal or ceramic manufacturer. For C_S , it is PCB and MCU pin stray capacitance.
- (4) $t_{SULXTAL}$ is the startup time measured from the moment it is enabled (by software) to the 32.768 kHz oscillator stabilization flags is SET. This value varies significantly with the crystal manufacturer.



Table 4-15. Low speed external user clock characteristics (LXTAL in bypass mode)

Symbol	Parameter	Conditions	Min	Typ	Max	Unit
$f_{LXTAL_ext}^{(1)}$	External clock source or oscillator frequency	$V_{DD} = 3.3\text{ V}$	—	32.768	1000	kHz
$V_{LXTALH}^{(2)}$	OSC32IN input pin high level voltage	—	$0.7 V_{DD}$	—	V_{DD}	V
$V_{LXTALL}^{(2)}$	OSC32IN input pin low level voltage	—	V_{SS}	—	$0.3 V_{DD}$	
$t_{H/L(LXTAL)}^{(2)}$	OSC32IN high or low time	—	450	—	—	ns
$t_{R/F(LXTAL)}^{(2)}$	OSC32IN rise or fall time	—	—	—	50	
$C_{IN}^{(2)}$	OSC32IN input capacitance	—	—	5	—	pF
$D_{ucy(LXTAL)}^{(2)}$	Duty cycle	—	30	50	70	%

- (1) Based on characterization, not tested in production.
- (2) Guaranteed by design, not tested in production.

4.8. Internal clock characteristics

Table 4-16. High speed internal clock (IRC8M) characteristics

Symbol	Parameter	Conditions	Min	Typ	Max	Unit
f_{IRC8M}	High Speed Internal Oscillator (IRC8M) frequency	$V_{DD} = V_{DDA} = 3.3\text{ V}$	—	8	—	MHz
ACC_{IRC8M}	IRC8M oscillator Frequency accuracy, Factory-trimmed	$V_{DD} = V_{DDA} = 3.3\text{ V}$, $T_A = -40^\circ\text{C} \sim +85^\circ\text{C}^{(1)}$	-2.5	—	+1.5	%
		$V_{DD} = V_{DDA} = 3.3\text{ V}$, $T_A = 0^\circ\text{C} \sim +85^\circ\text{C}^{(1)}$	-1.2	—	+1.2	%
		$V_{DD} = V_{DDA} = 3.3\text{ V}$, $T_A = 25^\circ\text{C}$	-1	—	+1	%
	IRC8M oscillator Frequency accuracy, User trimming step ⁽¹⁾	—	—	0.5	—	%
$D_{ucyIRC8M}^{(2)}$	IRC8M oscillator duty cycle	$V_{DD} = V_{DDA} = 3.3\text{ V}$	48	50	52	%
$I_{DDAIRC8M}^{(1)}$	IRC8M oscillator operating current	$V_{DD} = V_{DDA} = 3.3\text{ V}$, $f_{HCLK} = f_{HXTAL_PLL} = 108\text{ MHz}$	—	80	—	μA
$t_{SUIRC8M}^{(1)}$	IRC8M oscillator startup time	$V_{DD} = V_{DDA} = 3.3\text{ V}$, $f_{HCLK} = f_{HXTAL_PLL} = 108\text{ MHz}$	—	2	—	μs

- (1) Based on characterization, not tested in production.
- (2) Guaranteed by design, not tested in production.



Table 4-17. Low speed internal clock (IRC40K) characteristics

Symbol	Parameter	Conditions	Min	Typ	Max	Unit
$f_{IRC40K}^{(1)}$	Low Speed Internal oscillator (IRC40K) frequency	$V_{DD} = V_{DDA} = 3.3 V$, $T_A = -40\text{ }^{\circ}\text{C} \sim +85\text{ }^{\circ}\text{C}$	30	40	60	kHz
$I_{DDAIRC40K}^{(2)}$	IRC40K oscillator operating current	$V_{DD} = V_{DDA} = 3.3 V$, $f_{HCLK} = f_{HXTAL_PLL} = 108\text{ MHz}$ $T_A = 25\text{ }^{\circ}\text{C}$	—	2	—	μA
$t_{SUIRC40K}^{(2)}$	IRC40K oscillator startup time	$V_{DD} = V_{DDA} = 3.3 V$, $f_{HCLK} = f_{HXTAL_PLL} = 108\text{ MHz}$ $T_A = 25\text{ }^{\circ}\text{C}$	—	100	—	μs

- (1) Guaranteed by design, not tested in production.
- (2) Based on characterization, not tested in production.

4.9. PLL characteristics

Table 4-18. PLL characteristics

Symbol	Parameter	Conditions	Min	Typ	Max	Unit
$f_{PLLIN}^{(1)}$	PLL input clock frequency	—	1	—	25	MHz
$f_{PLLOUT}^{(2)}$	PLL output clock frequency	—	16	—	108	MHz
$f_{VCO}^{(2)}$	PLL VCO output clock frequency	—	32	—	—	MHz
$t_{LOCK}^{(2)}$	PLL lock time	—	—	—	400	μs
$I_{DDA}^{(1)(3)}$	Current consumption on V_{DDA}	VCO freq = 216 MHz	—	906	—	μA
$Jitter_{PLL}^{(1)(4)}$	Cycle to cycle Jitter (rms)	System clock	—	35	—	ps
	Cycle to cycle Jitter (peak to peak)		—	371	—	

- (1) Based on characterization, not tested in production.
- (2) Guaranteed by design, not tested in production.
- (3) System clock = HXTAL = 8 MHz, $f_{PLLOUT} = 108\text{ MHz}$.
- (4) Value given with main PLL running.

Table 4-19. PLL1/2 characteristics

Symbol	Parameter	Conditions	Min	Typ	Max	Unit
$f_{PLLIN}^{(1)}$	PLL input clock frequency	—	1	—	25	MHz
$f_{PLLOUT}^{(2)}$	PLL output clock frequency	—	16	—	108	MHz
$f_{VCO}^{(2)}$	VCO output frequency	—	32	—	216	MHz
$t_{LOCK}^{(2)}$	PLL lock time	—	—	—	400	μs
$I_{DDA}^{(1)(3)}$	Current consumption on V_{DDA}	VCO freq = 216 MHz	—	145	—	μA
$Jitter_{PLL}^{(1)(4)}$	Cycle to cycle Jitter (rms)	System clock	—	35	—	ps



	Cycle to cycle Jitter (peak to peak)		—	371	—	
--	---	--	---	-----	---	--

- (1) Based on characterization, not tested in production.
- (2) Guaranteed by design, not tested in production.
- (3) System clock = HXTAL = 8 MHz, f_{PLL}OUT = 108 MHz.
- (4) Value given with main PLL running

4.10. Memory characteristics

Table 4-20. Flash memory characteristics

Symbol	Parameter	Conditions	Min ⁽¹⁾	Typ ⁽¹⁾	Max ⁽²⁾	Unit
PE _{CYC}	Number of guaranteed program /erase cycles before failure (Endurance)	T _A = -40 °C ~ +85 °C	100	—	—	kcycles
t _{RET}	Data retention time	T _A = 125 °C	—	20	—	years
w _T PROG	Word programming time	T _A = -40 °C ~ +85 °C	—	37.5	86	μs
t _{ERASE}	Page erase time	T _A = -40 °C ~ +85 °C	—	45	300	ms
t _{MERASE(128K)}	Mass erase time	T _A = -40 °C ~ +85 °C	—	1	3.2	s

- (1) Based on characterization, not tested in production.
- (2) Guaranteed by design, not tested in production.

4.11. NRST pin characteristics

Table 4-21. NRST pin characteristics

Symbol	Parameter	Conditions	Min	Typ	Max	Unit
V _{IL(NRST)} ⁽¹⁾	NRST Input low level voltage	2.6 V ≤ V _{DD} = V _{D_{DA}} ≤ 3.6 V	-0.5	—	0.3 V _{DD}	V
V _{IH(NRST)} ⁽¹⁾	NRST Input high level voltage		0.7 V _{DD}	—	V _{DD} + 0.5	
V _{hyst} ⁽¹⁾	Schmidt trigger Voltage hysteresis		—	210	—	mV
R _{pu} ⁽²⁾	Pull-up equivalent resistor	—	—	40	—	kΩ

- (1) Based on characterization, not tested in production.
- (2) Guaranteed by design, not tested in production.

Figure 4-4. Recommended external NRST pin circuit⁽¹⁾

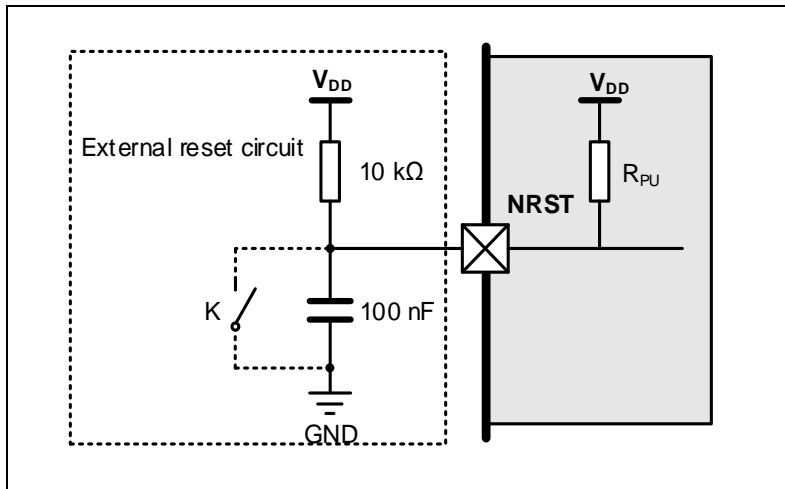

(1) Unless the voltage on NRST pin go below $V_{IL(NRST)}$ level, the device would not generate a reliable reset.

4.12. GPIO characteristics

Table 4-22. I/O port DC characteristics⁽¹⁾⁽³⁾

Symbol	Parameter	Conditions	Min	Typ	Max	Unit	
V_{IL}	Standard IO Low level input voltage	$2.6\text{ V} \leq V_{DD} = V_{DDA} \leq 3.6\text{ V}$	—	—	$0.3 V_{DD}$	V	
	5V-tolerant IO Low level input voltage	$2.6\text{ V} \leq V_{DD} = V_{DDA} \leq 3.6\text{ V}$	—	—	$0.3 V_{DD}$	V	
V_{IH}	Standard IO High level input voltage	$2.6\text{ V} \leq V_{DD} = V_{DDA} \leq 3.6\text{ V}$	$0.7 V_{DD}$	—	—	V	
	5V-tolerant IO High level input voltage	$2.6\text{ V} \leq V_{DD} = V_{DDA} \leq 3.6\text{ V}$	$0.7 V_{DD}$	—	—	V	
V_{OL}	Low level output voltage for each IO Pins ($I_{IO} = +8\text{ mA}$)	$V_{DD} = 2.6\text{ V}$	—	—	0.3	V	
		$V_{DD} = 3.3\text{ V}$	—	—	0.3		
		$V_{DD} = 3.6\text{ V}$	—	—	0.3		
V_{OL}	Low level output voltage for each IO Pins ($I_{IO} = +20\text{ mA}$)	$V_{DD} = 2.6\text{ V}$	—	—	1	V	
		$V_{DD} = 3.3\text{ V}$	—	—	0.8		
		$V_{DD} = 3.6\text{ V}$	—	—	0.7		
V_{OH}	High level output voltage for each IO Pins ($I_{IO} = +8\text{ mA}$)	$V_{DD} = 2.6\text{ V}$	2.3	—	—	V	
		$V_{DD} = 3.3\text{ V}$	3.0	—	—		
		$V_{DD} = 3.6\text{ V}$	3.3	—	—		
V_{OH}	High level output voltage for each IO Pins ($I_{IO} = +20\text{ mA}$)	$V_{DD} = 2.6\text{ V}$	1.5	—	—	V	
		$V_{DD} = 3.3\text{ V}$	2.6	—	—		
		$V_{DD} = 3.6\text{ V}$	2.8	—	—		
$R_{PU}^{(2)}$	Internal pull-up resistor	All pins	$V_{IN} = V_{SS}$	—	40	—	kΩ
		PA10	—	—	10	—	
$R_{PD}^{(2)}$	Internal pull-	All pins	$V_{IN} = V_{DD}$	—	40	—	kΩ

Symbol	Parameter		Conditions	Min	Typ	Max	Unit
	down resistor	PA10	—	—	10	—	

- (1) Based on characterization, not tested in production.
- (2) Guaranteed by design, not tested in production.
- (3) All pins except PC13 / PC14 / PC15. Since PC13 to PC15 are supplied through the Power Switch, which can only be obtained by a small current (typical source capability:3 mA shared between these IOs, but sink capability is same as other IO), the speed of GPIOs PC13 to PC15 should not exceed 2 MHz when they are in output mode(maximum load: 30 pF).

Table 4-23. I/O port AC characteristics⁽¹⁾⁽²⁾

GPIOx_MDy[1:0] bit value ⁽³⁾	Parameter	Conditions	Max	Unit
GPIOx_CTL->MDy[1:0] = 10 (IO_Speed = 2 MHz)	Maximum frequency ⁽⁴⁾	V _{DD} = 2.6 V, C _L = 10 pF	6	MHz
		V _{DD} = 2.6 V, C _L = 30 pF	4	
		V _{DD} = 2.6 V, C _L = 50 pF	2	
		V _{DD} = 3.3 V, C _L = 10 pF	8	
		V _{DD} = 3.3 V, C _L = 30 pF	6	
		V _{DD} = 3.3 V, C _L = 50 pF	4	
GPIOx_CTL->MDy[1:0] = 01 (IO_Speed = 10 MHz)	Maximum frequency ⁽⁴⁾	V _{DD} = 2.6 V, C _L = 10 pF	16	MHz
		V _{DD} = 2.6 V, C _L = 30 pF	12	
		V _{DD} = 2.6 V, C _L = 50 pF	10	
		V _{DD} = 3.3 V, C _L = 10 pF	20	
		V _{DD} = 3.3 V, C _L = 30 pF	16	
		V _{DD} = 3.3 V, C _L = 50 pF	14	
GPIOx_CTL->MDy[1:0] = 11 (IO_Speed = 50 MHz)	Maximum frequency ⁽⁴⁾	V _{DD} = 2.6 V, C _L = 10 pF	108	MHz
		V _{DD} = 2.6 V, C _L = 30 pF	100	
		V _{DD} = 2.6 V, C _L = 50 pF	72	
		V _{DD} = 3.3 V, C _L = 10 pF	108	
		V _{DD} = 3.3 V, C _L = 30 pF	100	
		V _{DD} = 3.3 V, C _L = 50 pF	80	

- (1) Based on characterization, not tested in production.
- (2) Unless otherwise specified, all test results given for T_A = 25 °C.
- (3) The I/O speed is configured using the GPIOx_CTL -> MDy[1:0] bits. Refer to the GD32VF103xx user manual which is selected to set the GPIO port output speed.
- (4) The maximum frequency is defined in Figure 4-5 and maximum frequency cannot exceed 108 MHz.

Figure 4-5. I/O port AC characteristics definition

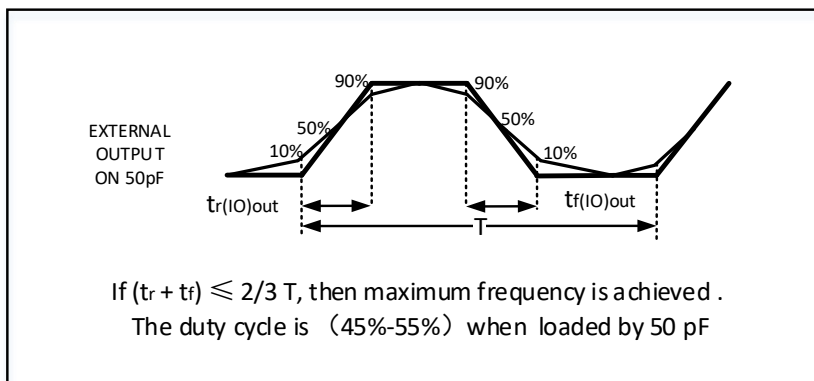

4.13. ADC characteristics

Table 4-24. ADC characteristics

Symbol	Parameter	Conditions	Min	Typ	Max	Unit
V _{DDA} ⁽¹⁾	Operating voltage	—	2.6	3.3	3.6	V
V _{IN} ⁽¹⁾	ADC input voltage range	—	0	—	V _{REFP}	V
f _{ADC} ⁽¹⁾	ADC clock	—	0.6	—	14	MHz
f _s ⁽¹⁾	Sampling rate	12-bit	0.04	—	1	MSPS
		10-bit	0.05	—	1.17	
		8-bit	0.06	—	1.4	
		6-bit	0.08	—	1.75	
V _{AIN} ⁽¹⁾	Analog input voltage	16 external; 2 internal	0	—	V _{DDA}	V
V _{REFP} ^{(2) (3)}	Positive Reference Voltage	—	2.4	—	V _{DDA}	V
V _{REFN} ⁽²⁾	Negative Reference Voltage	—	—	V _{SSA}	—	V
R _{AIN} ⁽²⁾	External input impedance	See Equation 1	—	—	320	kΩ
R _{ADC} ⁽²⁾	Input sampling switch resistance	—	—	—	0.55	kΩ
C _{ADC} ⁽²⁾	Input sampling capacitance	No pin/pad capacitance included	—	—	5.5	pF
t _s ⁽²⁾	Sampling time	f _{ADC} = 14 MHz	0.1	—	17.1	μs
t _{CONV} ⁽²⁾	Total conversion time(including sampling time)	12-bit	—	14	—	1/ f _{ADC}
		10-bit	—	12	—	
		8-bit	—	10	—	
		6-bit	—	8	—	
t _{SU} ⁽²⁾	Startup time	—	—	—	1	μs

(1) Based on characterization, not tested in production.

(2) Guaranteed by design, not tested in production.

(3) V_{REFP} should always be equal to or less than V_{DDA}, especially during power up.

Equation 1: R_{AIN} max formula
$$R_{AIN} < \frac{T_s}{f_{ADC} \cdot C_{ADC} \cdot \ln(2^{N+2})} - R_{ADC}$$

The formula above (Equation 1) is used to determine the maximum external impedance allowed for an error below 1/4 of LSB. Here N = 12 (from 12-bit resolution).

Table 4-25. ADC R_{AIN} max for f_{ADC} = 14 MHz⁽¹⁾

T _s (cycles)	t _s (us)	R _{AIN} max (kΩ)
1.5	0.11	1.46
7.5	0.54	9.49
13.5	0.96	17.5
28.5	2.04	37.6
41.5	2.96	55
55.5	3.96	73.7



T_s (cycles)	t_s (μ s)	R_{AINmax} (k Ω)
71.5	5.11	95
239.5	17.11	320

(1) Guaranteed by design, not tested in production.

4.14. Temperature sensor characteristics

Table 4-26. Temperature sensor characteristics⁽¹⁾

Symbol	Parameter	Min	Typ	Max	Unit
T_L	V_{SENSE} linearity with temperature	—	± 1.5	—	$^{\circ}C$
Avg_Slope	Average slope	—	4.1	—	mV/ $^{\circ}C$
V_{25}	Voltage at 25 $^{\circ}C$	—	1.45	—	V
t_{S_temp} ⁽²⁾	ADC sampling time when reading the temperature	—	17.1	—	μ s

(1) Based on characterization, not tested in production.

(2) Shortest sampling time can be determined in the application by multiple iterations.

4.15. DAC characteristics

Table 4-27. DAC characteristics

Symbol	Parameter	Conditions	Min	Typ	Max	Unit
V_{DDA} ⁽¹⁾	Operating voltage	—	2.6	3.3	3.6	V
V_{REFP} ⁽²⁾	Positive Reference Voltage	—	2.4	—	V_{DDA}	V
V_{REFN} ⁽²⁾	Negative Reference Voltage	—	—	V_{SSA}	—	V
R_{LOAD} ⁽²⁾	Load resistance	Resistive load with buffer ON	5	—	—	k Ω
R_o ⁽²⁾	Impedance output with buffer OFF	—	—	—	15	k Ω
C_{LOAD} ⁽²⁾	Load capacitance	No pin/pad capacitance included	—	—	50	pF
DAC_OUT_min ⁽²⁾	Lower DAC_OUT voltage with buffer ON	—	0.2	—	—	V
DAC_OUT_max ⁽²⁾	Higher DAC_OUT voltage with buffer ON	—	—	—	$V_{DDA} - 0.2$	V
DAC_OUT_min ⁽²⁾	Lower DAC_OUT voltage with buffer OFF	—	—	0.5	—	mV
DAC_OUT_max ⁽²⁾	Higher DAC_OUT voltage with buffer OFF	—	—	—	$V_{DDA} - 1LSB$	V
I_{DDA} ⁽¹⁾	DAC current consumption in quiescent mode	With no load, middle code(0x800) on the input, $V_{REFP} = 3.6$ V	—	470	—	μ A
		With no load, worst	—	570	—	μ A



Symbol	Parameter	Conditions	Min	Typ	Max	Unit
		code(0xF1C) on the input, $V_{REFP} = 3.6\text{ V}$				
$I_{DDVREFP}^{(1)}$	DAC current consumption in quiescent mode	With no load, middle code(0x800) on the input, $V_{REFP} = 3.6\text{ V}$	—	90	—	μA
		With no load, worst code(0xF1C) on the input, $V_{REFP} = 3.6\text{ V}$	—	298	—	μA
$DNL^{(1)}$	Differential non-linearity error	DAC in 12-bit mode	—	—	± 3	LSB
$INL^{(1)}$	Integral non-linearity	DAC in 12-bit mode	—	—	± 4	LSB
Offset ⁽¹⁾	Offset error	DAC in 12-bit mode	—	—	± 12	LSB
$GE^{(1)}$	Gain error	DAC in 12-bit mode	—	—	± 0.5	%
$T_{\text{setting}}^{(1)}$	Settling time	$C_{LOAD} \leq 50\text{ pF}$, $R_{LOAD} \geq 5\text{ k}\Omega$	—	0.3	1	μs
$T_{\text{wakeup}}^{(2)}$	Wakeup from off state	—	—	5	10	μs
Update rate ⁽²⁾	Max frequency for a correct DAC_OUT change from code i to $i \pm 1$ LSBs	$C_{LOAD} \leq 50\text{ pF}$, $R_{LOAD} \geq 5\text{ k}\Omega$	—	—	4	MS/s
$PSRR^{(2)}$	Power supply rejection ratio (to V_{DDA})	—	55	80	—	dB

(1) Based on characterization, not tested in production.

(2) Guaranteed by design, not tested in production.

4.16. I2C characteristics

Table 4-28. I2C characteristics⁽¹⁾⁽²⁾

Symbol	Parameter	Conditions	Standard mode		Fast mode		Fast mode plus		Unit
			Min	Max	Min	Max	Min	Max	
$t_{SCL(H)}$	SCL clock high time	—	4.0	—	0.6	—	0.2	—	μs
$t_{SCL(L)}$	SCL clock low time	—	4.7	—	1.3	—	0.5	—	μs
$t_{SU(SDA)}$	SDA setup time	—	250	—	100	—	50	—	ns
$t_{H(SDA)}$	SDA data hold time	—	0 ⁽³⁾	3450	0	900	0	450	ns
$t_{R(SDA/SCL)}$	SDA and SCL rise time	—	—	1000	—	300	—	120	ns
$t_{F(SDA/SCL)}$	SDA and SCL fall time	—	—	300	—	300	—	120	ns

Symbol	Parameter	Conditions	Standard mode		Fast mode		Fast mode plus		Unit
			Min	Max	Min	Max	Min	Max	
$t_{H(STA)}$	Start condition hold time	—	4.0	—	0.6	—	0.26	—	μs
$t_{SU(STA)}$	Repeated Start condition setup time	—	4.7	—	0.6	—	0.26	—	μs
$t_{SU(STO)}$	Stop condition setup time	—	4.0	—	0.6	—	0.26	—	μs
t_{BUFF}	Stop to Start condition time (bus free)	—	4.7	—	1.3	—	0.5	—	μs

- (1) Guaranteed by design, not tested in production.
- (2) To ensure the standard mode I2C frequency, f_{PCLK1} must be at least 2 MHz. To ensure the fast mode I2C frequency, f_{PCLK1} must be at least 4 MHz. To ensure the fast mode plus I2C frequency, f_{PCLK1} must be at least a multiple of 10 MHz.
- (3) The device should provide a data hold time of 300 ns at least in order to bridge the undefined region of the falling edge of SCL.

Figure 4-6. I2C bus timing diagram

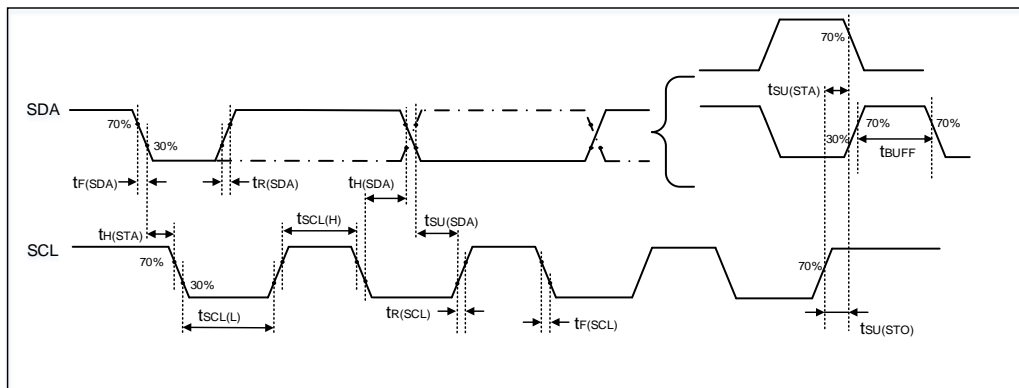

4.17. SPI characteristics

Table 4-29. Standard SPI characteristics⁽¹⁾

Symbol	Parameter	Conditions	Min	Typ	Max	Unit
f_{SCK}	SCK clock frequency	—	—	—	27	MHz
$t_{SCK(H)}$	SCK clock high time	Master mode, $f_{PCLKx} = 108$ MHz, presc = 8	35	37	39	ns
$t_{SCK(L)}$	SCK clock low time	Master mode, $f_{PCLKx} = 108$ MHz, presc = 8	35	37	39	ns
SPI master mode						
$t_{V(MO)}$	Data output valid time	—	—	7	—	ns
$t_{H(MO)}$	Data output hold time	—	—	4	—	ns

$t_{SU(MI)}$	Data input setup time	—	1	—	—	ns
$t_{H(MI)}$	Data input hold time	—	0	—	—	ns
SPI slave mode						
$t_{SU(NSS)}$	NSS enable setup time	$f_{PCLK} = 54 \text{ MHz}$	0	—	—	ns
$t_{H(NSS)}$	NSS enable hold time	$f_{PCLK} = 54 \text{ MHz}$	1	—	—	ns
$t_{A(SO)}$	Data output access time	—	—	9	—	ns
$t_{DIS(SO)}$	Data output disable time	—	—	8	—	ns
$t_{V(SO)}$	Data output valid time	—	—	10	—	ns
$t_{H(SO)}$	Data output hold time	—	—	10	—	ns
$t_{SU(SI)}$	Data input setup time	—	0	—	—	ns
$t_{H(SI)}$	Data input hold time	—	1	—	—	ns

(1) Based on characterization, not tested in production.

Figure 4-7. SPI timing diagram - master mode

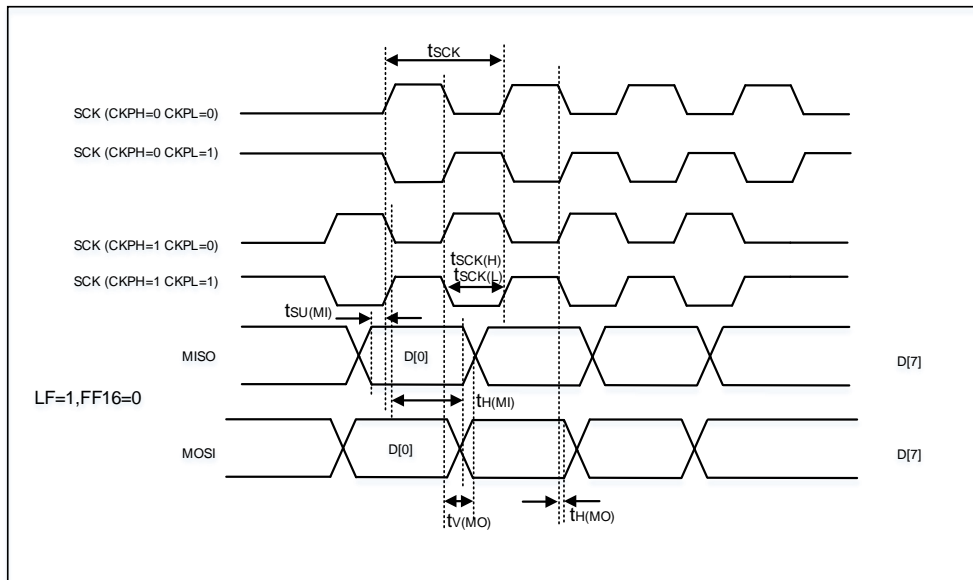
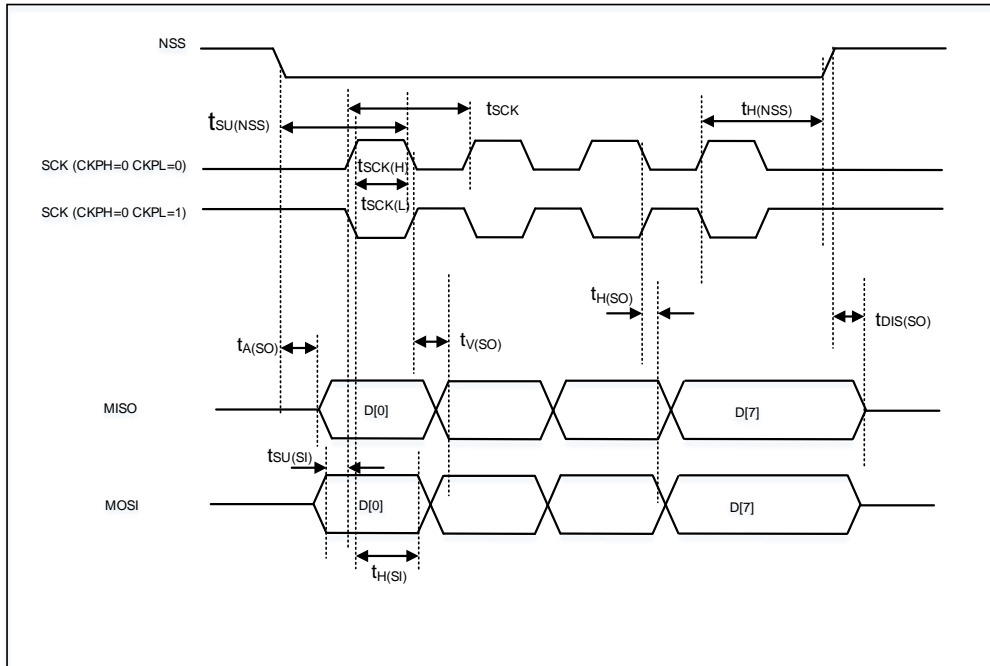

Figure 4-8. SPI timing diagram - slave mode



4.18. I2S characteristics

Table 4-30. I2S characteristics⁽¹⁾⁽²⁾

Symbol	Parameter	Conditions	Min	Typ	Max	Unit
f_{CK}	Clock frequency	Master mode (data: 16 bits, Audio frequency = 96 kHz)	3.070	3.072	3.074	MHz
		Slave mode	—	10	—	
t_H	Clock high time	—	—	162	—	ns
t_L	Clock low time		—	163	—	ns
$t_{V(WS)}$	WS valid time	Master mode	—	2	—	ns
$t_{H(WS)}$	WS hold time	Master mode	—	2	—	ns
$t_{SU(WS)}$	WS setup time	Slave mode	0	—	—	ns
$t_{H(WS)}$	WS hold time	Slave mode	1	—	—	ns
$Ducy(SCK)$	I2S slave input clock duty cycle	Slave mode	—	50	—	%
$t_{SU(SD_MR)}$	Data input setup time	Master mode	3	—	—	ns
$t_{SU(SD_SR)}$	Data input setup time	Slave mode	0	—	—	ns
$t_{H(SD_MR)}$	Data input hold time	Master receiver	0	—	—	ns
$t_{H(SD_SR)}$		Slave receiver	1	—	—	ns
$t_{V(SD_ST)}$	Data output valid time	Slave transmitter (after enable edge)	—	12	—	ns
$t_{H(SD_ST)}$	Data output hold time	Slave transmitter	—	10	—	ns

Symbol	Parameter	Conditions	Min	Typ	Max	Unit
		(after enable edge)				
$t_{V(SD_MT)}$	Data output valid time	Master transmitter (after enable edge)	—	10	—	ns
$t_{H(SD_MT)}$	Data output hold time	Master transmitter (after enable edge)	—	7	—	ns

- (1) Guaranteed by design, not tested in production.
 (2) Based on characterization, not tested in production.

Figure 4-9. I2S timing diagram - master mode

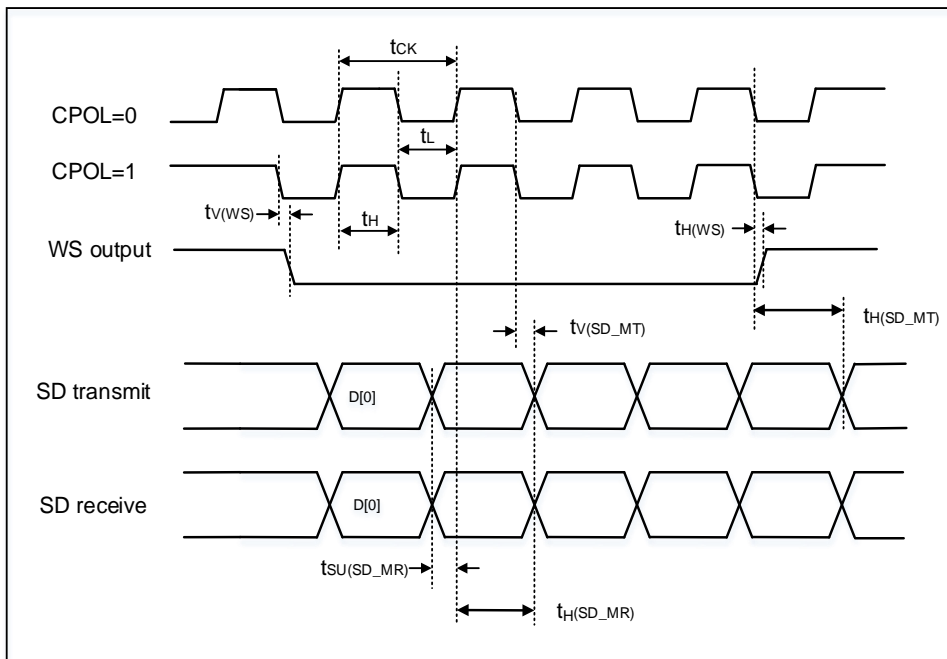
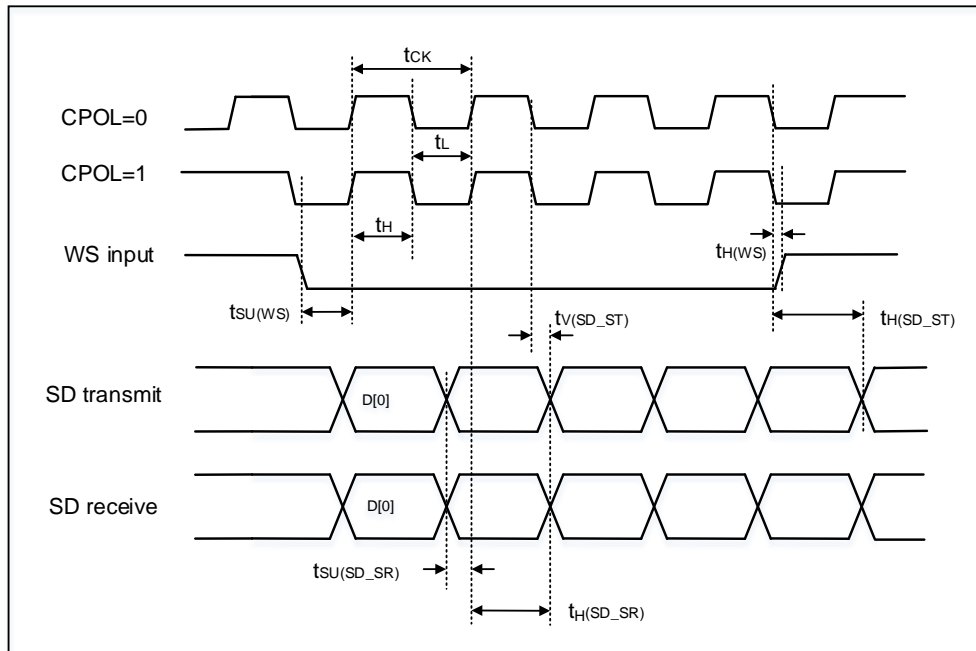

Figure 4-10. I2S timing diagram - slave mode



4.19. USART characteristics

Table 4-31. USART0 characteristics⁽¹⁾

Symbol	Parameter	Conditions	Min	Typ	Max	Unit
f_{SCK}	SCK clock frequency	$f_{PCLKx} = 108 \text{ MHz}$	—	—	54	MHz
$t_{SCK(H)}$	SCK clock high time	$f_{PCLKx} = 108 \text{ MHz}$	4.63	—	—	ns
$t_{SCK(L)}$	SCK clock low time	$f_{PCLKx} = 108 \text{ MHz}$	4.63	—	—	ns

(1) Guaranteed by design, not tested in production.

Table 4-32. USART1-2/UART3-4 characteristics⁽¹⁾

Symbol	Parameter	Conditions	Min	Typ	Max	Unit
f_{SCK}	SCK clock frequency	$f_{PCLKx} = 108 \text{ MHz}$	—	—	54	MHz
$t_{SCK(H)}$	SCK clock high time	$f_{PCLKx} = 108 \text{ MHz}$	9.26	—	—	ns
$t_{SCK(L)}$	SCK clock low time	$f_{PCLKx} = 108 \text{ MHz}$	9.26	—	—	ns

(1) Guaranteed by design, not tested in production.

4.20. CAN characteristics

Refer to [Table 4-22. I/O port DC characteristics^{\(1\)}](#) for more details on the input/output alternate function characteristics (CANTX and CANRX).

4.21. USBFS characteristics

Table 4-33. USBFS start up time

Symbol	Parameter	Max	Unit
$t_{STARTUP}^{(1)}$	USBFS startup time	1	μs

(1) Guaranteed by design, not tested in production.

Table 4-34. USBFS DC electrical characteristics

Symbol	Parameter	Conditions	Min	Typ	Max	Unit	
Input levels ⁽¹⁾	V_{DD}	USBFS operating voltage	—	3	—	3.6	V
	V_{DI}	Differential input sensitivity	I(USB _{DP} , USB _{DM})	0.2	—	—	V
	V_{CM}	Differential common mode range	Includes V_{DI} range	0.8	—	2.5	
	V_{SE}	Single ended receiver threshold	—	1.3	—	2.0	
Output levels ⁽²⁾	V_{OL}	Static output level low	R_L of 1.55 k Ω to 3.3 V	—	0.04	0.3	V
	V_{OH}	Static output level high	R_L of 21 k Ω to V_{SS}	2.8	3.3	3.6	

(1) Guaranteed by design, not tested in production.

(2) Based on characterization, not tested in production.

Table 4-35. USBFS electrical characteristics⁽¹⁾

Symbol	Parameter	Conditions	Min	Typ	Max	Unit
t_R	Rise time	$C_L = 50$ pF	4	—	20	ns
t_F	Fall time	$C_L = 50$ pF	4	—	20	ns
t_{RFM}	Rise / fall time matching	t_R / t_F	90	—	110	%
V_{CRS}	Output signal crossover voltage	—	1.3	—	2.0	V

(1) Guaranteed by design, not tested in production.

Figure 4-11. USBFS timings: definition of data signal rise and fall time

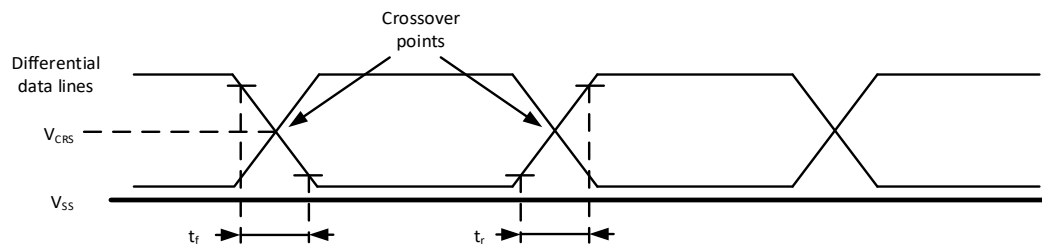

4.22. EXMC characteristics

Table 4-36. Asynchronous multiplexed PSRAM/NOR read timings⁽¹⁾⁽²⁾⁽³⁾

Symbol	Parameter	Min	Max	Unit
$t_{w(NE)}$	EXMC_NE low time	64.1	66.1	ns
$t_{V(NOE_NE)}$	EXMC_NEx low to EXMC_NOE low	26.9	—	ns
$t_{w(NOE)}$	EXMC_NOE low time	36.2	38.2	ns
$t_{h(NE_NOE)}$	EXMC_NOE high to EXMC_NE high hold time	0	—	ns



$t_{v(A_NE)}$	EXMC_NEx low to EXMC_A valid	0	—	ns
$t_{v(A_NOE)}$	Address hold time after EXMC_NOE high	0	—	ns
$t_{v(BL_NE)}$	EXMC_NEx low to EXMC_BL valid	0	—	ns
$t_{h(BL_NOE)}$	EXMC_BL hold time after EXMC_NOE high	0	—	ns
$t_{su(DATA_NE)}$	Data to EXMC_NEx high setup time	37.2	—	ns
$t_{su(DATA_NOE)}$	Data to EXMC_NOEx high setup time	37.2	—	ns
$t_{h(DATA_NOE)}$	Data hold time after EXMC_NOE high	0	—	ns
$t_{h(DATA_NE)}$	Data hold time after EXMC_NEx high	0	—	ns
$t_{v(NADV_NE)}$	EXMC_NEx low to EXMC_NADV low	0	—	ns
$t_{w(NADV)}$	EXMC_NADV low time	8.3	10.3	ns
$T_{h(AD_NADV)}$	EXMC_AD(address) valid hold time after EXMC_NADV high	8.3	10.3	ns

- (1) $C_L = 30$ pF.
- (2) Guaranteed by design, not tested in production.
- (3) Based on configure: $f_{HCLK} = 108$ MHz, AddressSetupTime = 0, AddressHoldTime = 1, DataSetupTime = 1.

Table 4-37. Asynchronous multiplexed PSRAM/NOR write timings⁽¹⁾⁽²⁾⁽³⁾

Symbol	Parameter	Min	Max	Unit
$t_{w(NE)}$	EXMC_NE low time	45.5	47.5	ns
$t_{v(NWE_NE)}$	EXMC_NEx low to EXMC_NWE low	8.3	—	ns
$t_{w(NWE)}$	EXMC_NWE low time	26.9	28.9	ns
$t_{h(NE_NWE)}$	EXMC_NWE high to EXMC_NE high hold time	8.3	—	ns
$t_{v(A_NE)}$	EXMC_NEx low to EXMC_A valid	0	—	ns
$t_{v(NADV_NE)}$	EXMC_NEx low to EXMC_NADV low	0	—	ns
$t_{w(NADV)}$	EXMC_NADV low time	8.3	10.3	ns
$T_{h(AD_NADV)}$	EXMC_AD(address) valid hold time after EXMC_NADV high	8.3	—	ns
$t_{h(A_NWE)}$	Address hold time after EXMC_NWE high	8.3	—	ns
$t_{h(BL_NWE)}$	EXMC_BL hold time after EXMC_NWE high	8.3	—	ns
$t_{v(BL_NE)}$	EXMC_NEx low to EXMC_BL valid	0	—	ns
$t_{v(DATA_NADV)}$	EXMC_NADV high to DATA valid	8.3	—	ns
$t_{h(DATA_NWE)}$	Data hold time after EXMC_NWE high	8.3	—	ns

- (1) $C_L = 30$ pF.
- (2) Guaranteed by design, not tested in production.
- (3) Based on configure: $f_{HCLK} = 108$ MHz, AddressSetupTime = 0, AddressHoldTime = 1, DataSetupTime = 1.

4.23. TIMER characteristics

Table 4-38. TIMER characteristics⁽¹⁾

Symbol	Parameter	Conditions	Min	Max	Unit
t_{res}	Timer resolution time	—	1	—	$t_{TIMERxCLK}$
		$f_{TIMERxCLK} = 108$ MHz	9.26	—	ns
f_{EXT}	Timer external clock	—	0	$f_{TIMERxCLK} / 2$	MHz



Symbol	Parameter	Conditions	Min	Max	Unit
	frequency	$f_{\text{TIMERxCLK}} = 108 \text{ MHz}$	0	54	MHz
RES	Timer resolution	—	—	16	bit
t_{COUNTER}	16-bit counter clock period when internal clock is selected	—	1	65536	$t_{\text{TIMERxCLK}}$
		$f_{\text{TIMERxCLK}} = 108 \text{ MHz}$	0.0093	607	μs
$t_{\text{MAX_COUNT}}$	Maximum possible count	—	—	65536x65536	$t_{\text{TIMERxCLK}}$
		$f_{\text{TIMERxCLK}} = 108 \text{ MHz}$	—	39.8	s

(1) Guaranteed by design, not tested in production.

4.24. WDGT characteristics

Table 4-39. FWDGT min/max timeout period at 40 kHz (IRC40K)⁽¹⁾

Prescaler divider	PR[2:0] bits	Min timeout RLD[11:0] = 0x000	Max timeout RLD[11:0] = 0xFFF	Unit
1/4	000	0.025	409.525	ms
1/8	001	0.025	819.025	
1/16	010	0.025	1638.025	
1/32	011	0.025	3276.025	
1/64	100	0.025	6552.025	
1/128	101	0.025	13104.025	
1/256	110 or 111	0.025	26208.025	

(1) Guaranteed by design, not tested in production.

Table 4-40. WWDGT min/max timeout value at 54 MHz (f_{PCLK1})⁽¹⁾

Prescaler divider	PSC[1:0]	Min timeout value CNT[6:0] = 0x40	Unit	Max timeout value CNT[6:0] = 0x7F	Unit
1/1	00	75.8	μs	4.85	ms
1/2	01	151.7		9.7	
1/4	10	303.4		19.4	
1/8	11	606.8		38.8	

(1) Guaranteed by design, not tested in production.

4.25. Parameter conditions

Unless otherwise specified, all values given for $V_{\text{DD}} = V_{\text{DDA}} = 3.3 \text{ V}$, $T_{\text{A}} = 25 \text{ }^\circ\text{C}$.



5. Package information

5.1. LQFP100 package outline dimensions

Figure 5-1. LQFP100 package outline

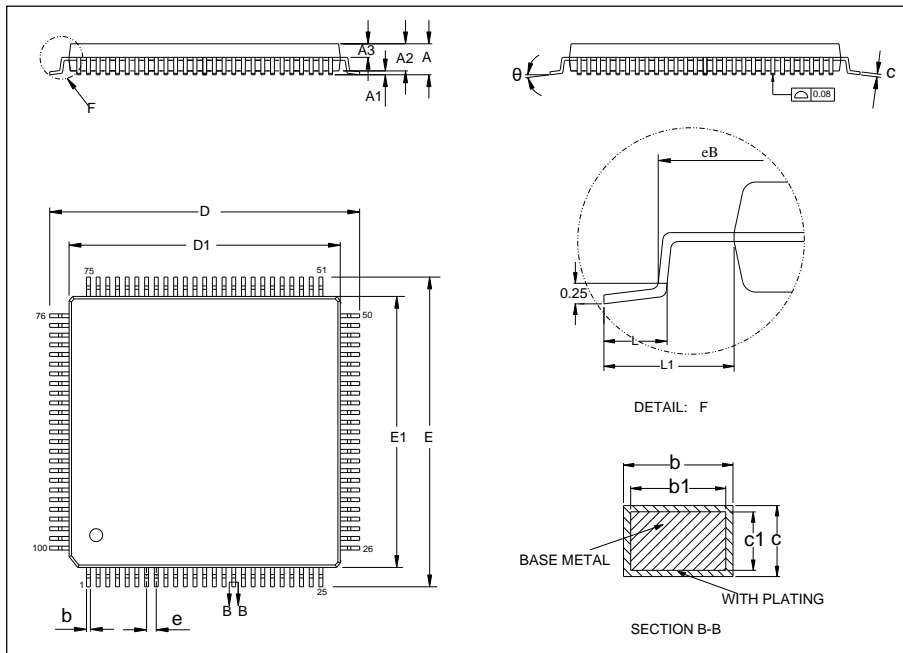
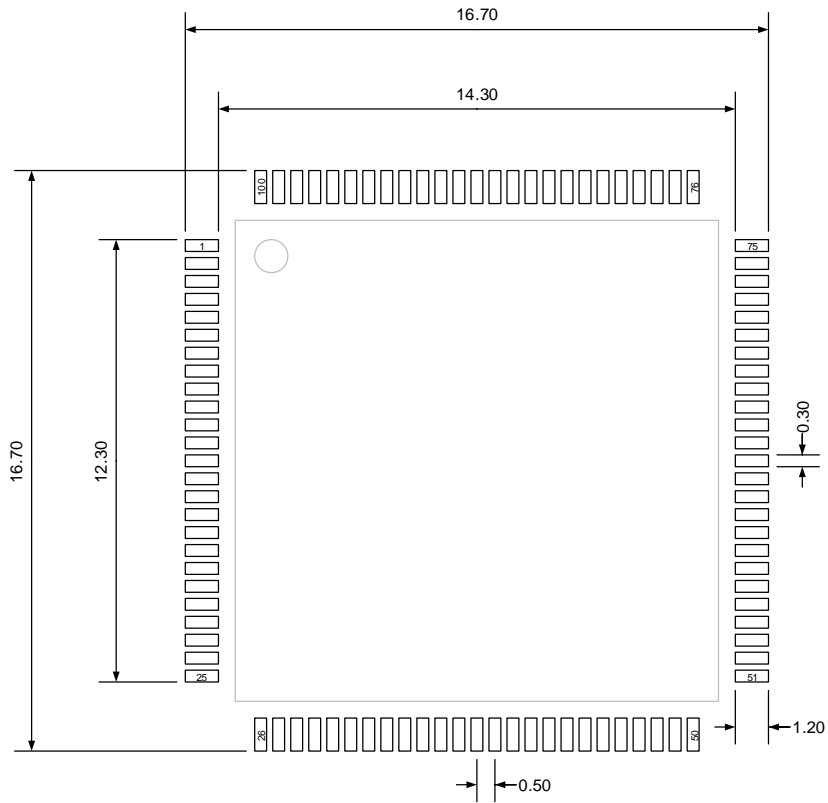

Table 5-1. LQFP100 package dimensions

Symbol	Min	Typ	Max
A	—	—	1.60
A1	0.05	—	0.15
A2	1.35	1.40	1.45
A3	0.59	0.64	0.69
b	0.18	—	0.26
b1	0.17	0.20	0.23
c	0.13	—	0.17
c1	0.12	0.13	0.14
D	15.80	16.00	16.20
D1	13.90	14.00	14.10
E	15.80	16.00	16.20
E1	13.90	14.00	14.10
e	—	0.50	—
eB	15.05	—	15.35
L	0.45	—	0.75
L1	—	1.00	—
θ	0°	—	7°

(Original dimensions are in millimeters)

Figure 5-2. LQFP100 recommended footprint



(Original dimensions are in millimeters)

5.2. LQFP64 package outline dimensions

Figure 5-3. LQFP64 package outline

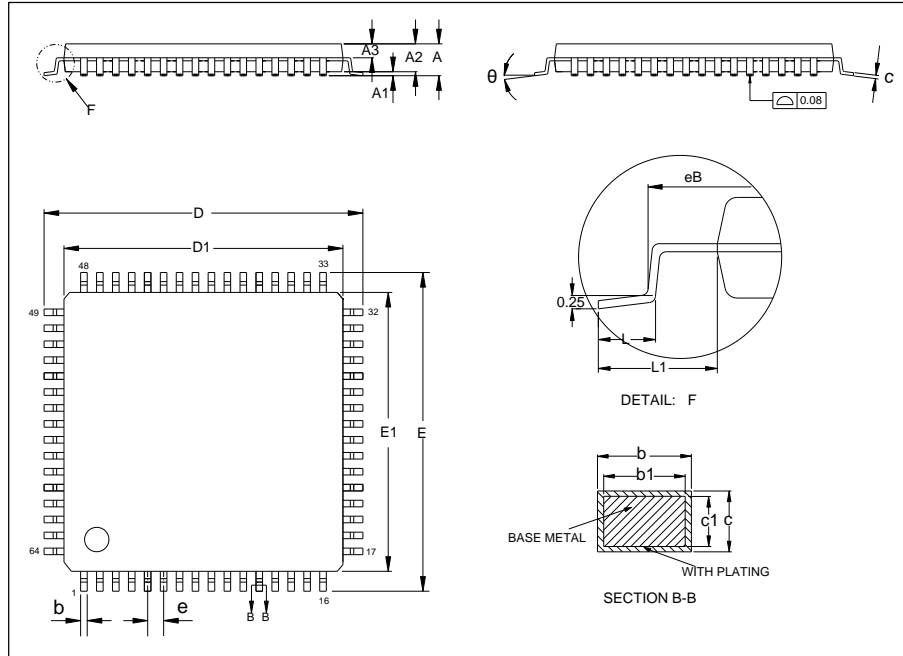
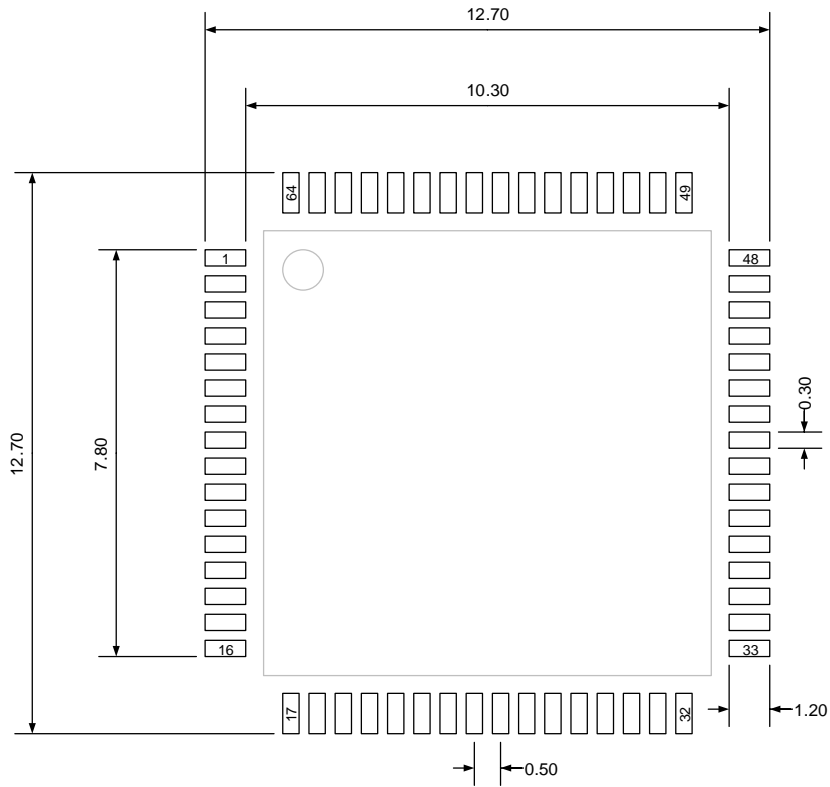

Table 5-2. LQFP64 package dimensions

Symbol	Min	Typ	Max
A	—	—	1.60
A1	0.05	—	0.15
A2	1.35	1.40	1.45
A3	0.59	0.64	0.69
b	0.18	—	0.26
b1	0.17	0.20	0.23
c	0.13	—	0.17
c1	0.12	0.13	0.14
D	11.80	12.00	12.20
D1	9.90	10.00	10.10
E	11.80	12.00	12.20
E1	9.90	10.00	10.10
e	—	0.50	—
eB	11.25	—	11.45
L	0.45	—	0.75
L1	—	1.00	—
θ	0°	—	7°

(Original dimensions are in millimeters)

Figure 5-4. LQFP64 recommended footprint



(Original dimensions are in millimeters)

5.3. LQFP48 package outline dimensions

Figure 5-5. LQFP48 package outline

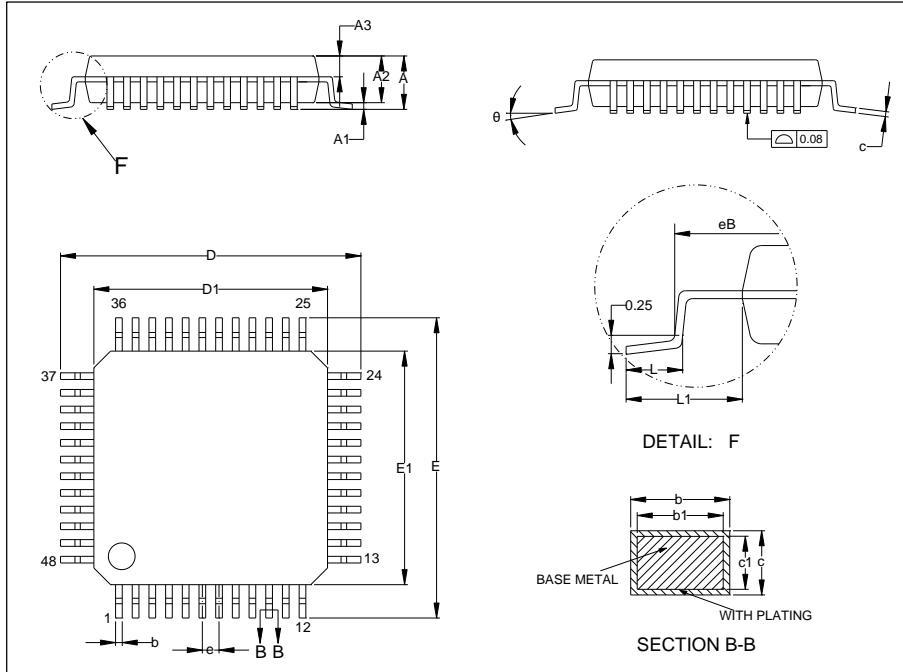
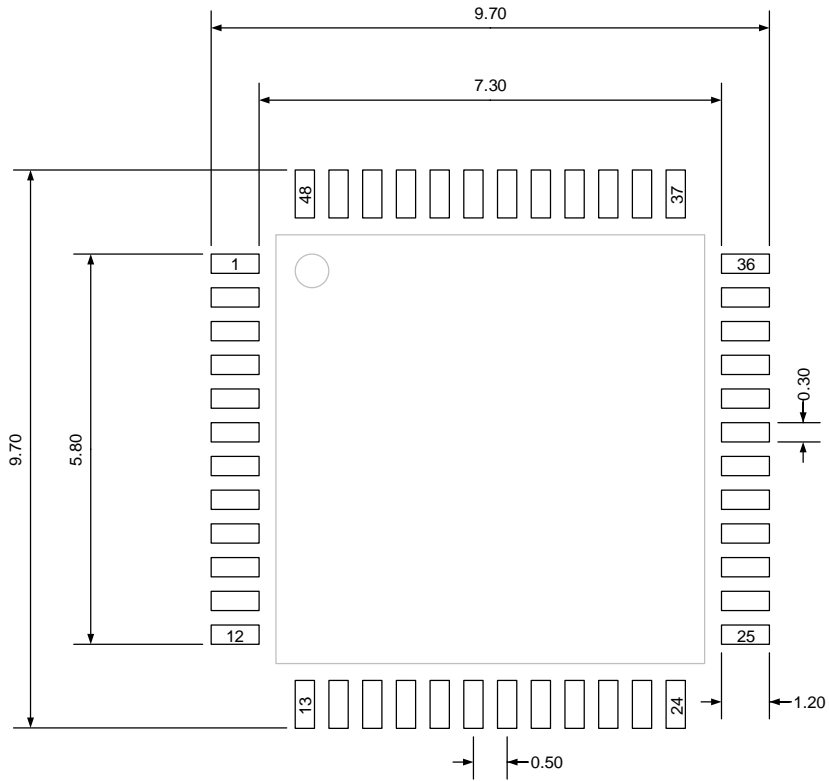

Table 5-3. LQFP48 package dimensions

Symbol	Min	Typ	Max
A	—	—	1.60
A1	0.05	—	0.15
A2	1.35	1.40	1.45
A3	0.59	0.64	0.69
b	0.18	—	0.26
b1	0.17	0.20	0.23
c	0.13	—	0.17
c1	0.12	0.13	0.14
D	8.80	9.00	9.20
D1	6.90	7.00	7.10
E	8.80	9.00	9.20
E1	6.90	7.00	7.10
e	—	0.50	—
eB	8.10	—	8.25
L	0.45	—	0.75
L1	—	1.00	—
θ	0°	—	7°

(Original dimensions are in millimeters)

Figure 5-6. LQFP48 recommended footprint



(Original dimensions are in millimeters)

5.4. QFN36 package outline dimensions

Figure 5-7. QFN36 package outline

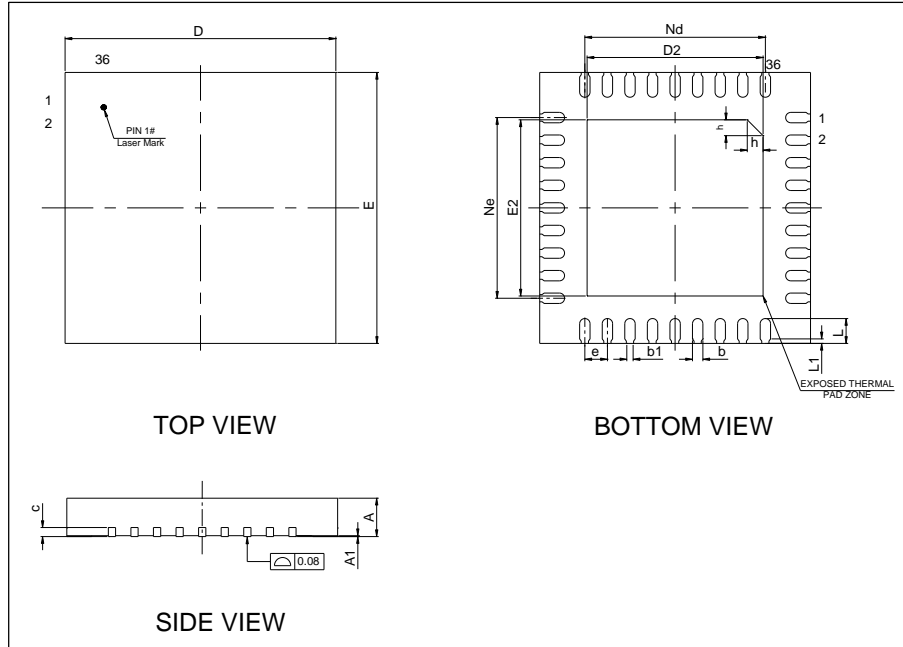
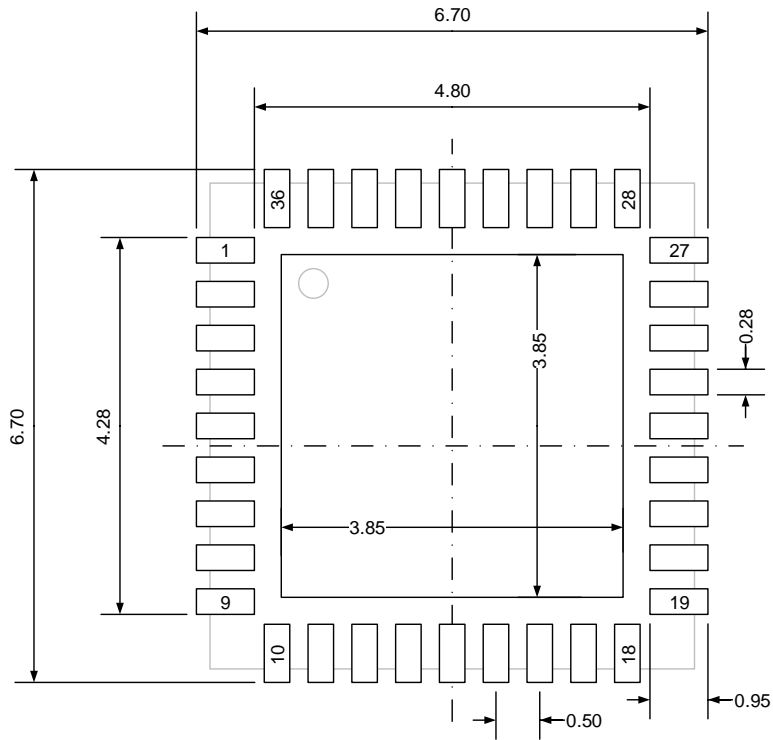

Table 5-4. QFN36 package dimensions

Symbol	Min	Typ	Max
A	0.80	0.85	0.90
A1	0	0.02	0.05
b	0.18	0.23	0.30
b1	—	0.16	—
c	0.18	0.20	0.23
D	5.90	6.00	6.10
D2	3.80	3.90	4.00
E	5.90	6.00	6.10
E2	3.80	3.90	4.00
e	—	0.50	—
h	0.30	0.35	0.40
L	0.50	0.55	0.60
L1	—	0.10	—
Nd	3.95	4.00	4.05
Ne	3.95	4.00	4.05

(Original dimensions are in millimeters)

Figure 5-8. QFN36 recommended footprint



(Original dimensions are in millimeters)

5.5. Thermal characteristics

Thermal resistance is used to characterize the thermal performance of the package device, which is represented by the Greek letter “ θ ”. For semiconductor devices, thermal resistance represents the steady-state temperature rise of the chip junction due to the heat dissipated on the chip surface.

θ_{JA} : Thermal resistance, junction-to-ambient.

θ_{JB} : Thermal resistance, junction-to-board.

θ_{JC} : Thermal resistance, junction-to-case.

ψ_{JB} : Thermal characterization parameter, junction-to-board.

ψ_{JT} : Thermal characterization parameter, junction-to-top center.

$$\theta_{JA}=(T_J-T_A)/P_D \quad (5-1)$$

$$\theta_{JB}=(T_J-T_B)/P_D \quad (5-2)$$

$$\theta_{JC}=(T_J-T_C)/P_D \quad (5-3)$$

Where, T_J = Junction temperature.

T_A = Ambient temperature

T_B = Board temperature

T_C = Case temperature which is monitoring on package surface

P_D = Total power dissipation

θ_{JA} represents the resistance of the heat flows from the heating junction to ambient air. It is an indicator of package heat dissipation capability. Lower θ_{JA} can be considerate as better overall thermal performance. θ_{JA} is generally used to estimate junction temperature.

θ_{JB} is used to measure the heat flow resistance between the chip surface and the PCB board.

θ_{JC} represents the thermal resistance between the chip surface and the package top case. θ_{JC} is mainly used to estimate the heat dissipation of the system (using heat sink or other heat dissipation methods outside the device package).

Table 5-5. Package thermal characteristics⁽¹⁾

Symbol	Condition	Package	Value	Unit
θ_{JA}	Natural convection, 2S2P PCB	LQFP100	57.42	°C/W
		LQFP64	61.80	
		LQFP48	64.40	
		QFN36	43.20	
θ_{JB}	Cold plate, 2S2P PCB	LQFP100	31.68	°C/W
		LQFP64	42.83	



Symbol	Condition	Package	Value	Unit
		LQFP48	42.32	
		QFN36	16.51	
θ_{JC}	Cold plate, 2S2P PCB	LQFP100	13.85	°C/W
		LQFP64	21.98	
		LQFP48	22.47	
		QFN36	16.18	
Ψ_{JB}	Natural convection, 2S2P PCB	LQFP100	41.28	°C/W
		LQFP64	43.05	
		LQFP48	42.42	
		QFN36	16.64	
Ψ_{JT}	Natural convection, 2S2P PCB	LQFP100	0.75	°C/W
		LQFP64	1.58	
		LQFP48	1.74	
		QFN36	1.07	

(1) Thermal characteristics are based on simulation, and meet JEDEC specification.

6. Ordering information

Table 6-1. Part ordering code for GD32VF103xx devices

Ordering code	Flash (KB)	Package	Package type	Temperature operating range
GD32VF103VBT6	128	LQFP100	Green	Industrial -40 °C to +85 °C
GD32VF103V8T6	64	LQFP100	Green	Industrial -40 °C to +85 °C
GD32VF103RBT6	128	LQFP64	Green	Industrial -40 °C to +85 °C
GD32VF103R8T6	64	LQFP64	Green	Industrial -40 °C to +85 °C
GD32VF103R6T6	32	LQFP64	Green	Industrial -40 °C to +85 °C
GD32VF103R4T6	16	LQFP64	Green	Industrial -40 °C to +85 °C
GD32VF103CBT6	128	LQFP48	Green	Industrial -40 °C to +85 °C
GD32VF103C8T6	64	LQFP48	Green	Industrial -40 °C to +85 °C
GD32VF103C6T6	32	LQFP48	Green	Industrial -40 °C to +85 °C
GD32VF103C4T6	16	LQFP48	Green	Industrial -40 °C to +85 °C
GD32VF103TBU6	128	QFN36	Green	Industrial -40 °C to +85 °C
GD32VF103T8U6	64	QFN36	Green	Industrial -40 °C to +85 °C
GD32VF103T6U6	32	QFN36	Green	Industrial -40 °C to +85 °C
GD32VF103T4U6	16	QFN36	Green	Industrial -40 °C to +85 °C

7. Revision History

Table 7-1. Revision history

Revision No.	Description	Date
1.0	Initial Release	Jun.5, 2019
1.1	<ol style="list-style-type: none"> 1. Clock tree modification, the factor for CK_CST changes from 8 to 4, refers to <u>Clock tree</u>. 2. Add I2C fast mode plus related information, refers to <u>I2C characteristics</u>. 	Sep.16,2019
1.2	<ol style="list-style-type: none"> 1. Chapter <u>Electrical characteristics</u> electrical characteristics update. 2. Chapter <u>Package information</u> package information update. 3. Delete the PD0,PD1 remap to OSC pins information in packages no less than100 pins, refers to <u>Pin definitions</u>. 	Feb.15,2020
1.3	<ol style="list-style-type: none"> 1. Chapter <u>PLL characteristics</u> modification. 2. Add description of V_{REF+} and V_{REF-} connection in chapter <u>Analog to digital converter (ADC)</u>. 3. Modify the LDO mode conditions in <u>Power consumption</u>. 4. Delete EXMC characteristics comments in chapter <u>EXMC characteristics</u>. 5. T_{STG} range changes to -65°C~+150°C in <u>Absolute maximum ratings</u>. 	Dec.15,2020
1.4	<ol style="list-style-type: none"> 1. Add I2C, SPI, I2S timing diagrams, refers to <u>I2C characteristics</u>, <u>SPI characteristics</u> and <u>I2S characteristics</u>. 	Mar.29,2021
1.5	<ol style="list-style-type: none"> 1. Update SPI and I2S timing diagrams, refers to <u>SPI characteristics</u> and <u>I2S characteristics</u>. 2. Update package information and ordering information, refers to <u>Package information</u> and <u>Ordering information</u>. 3. Modify WDGT characteristics, refers to <u>WDGT characteristics</u>. 	Dec.14, 2021
1.6	<ol style="list-style-type: none"> 1. Add P_D parameter in <u>Table 4-1. Absolute maximum ratings⁽¹⁾⁽⁴⁾</u>. 2. Modify I2C timing diagrams, refers to <u>I2C characteristics</u>. 3. Modify LQFP64 package information, refer to <u>LQFP64 package outline dimensions</u>. 4. Update NRST external pin circuit, refer to <u>Figure 4-4. Recommended external NRST pin circuit⁽¹⁾</u>. 	Jun.7, 2022



	5. EXMC related pin update, refer to <u>Pin definitions</u> .	
1.7	<ol style="list-style-type: none"> 1. Pin name modification in <u>Pin definitions</u> and <u>Pinouts and pin assignment</u>. 2. Modify comments to <u>Table 4-2. DC operating conditions</u>. 3. Add comments to <u>Power consumption</u>. 4. Modify <u>I2C characteristics</u> diagram <u>Figure 4-6. I2C bus timing diagram</u>. 5. Modify <u>I2S characteristics</u> diagram <u>Figure 4-9. I2S timing diagram - master mode</u> and <u>Figure 4-10. I2S timing diagram - slave mode</u>. 	Dec.5, 2022
1.8	<ol style="list-style-type: none"> 1. Modify VREF/VREF+ to VREFP, modify VREF- to VREFN. 2. Add related application note in the notes, refers to <u>Electrical characteristics</u>. 3. Modify format of pin definitions, refer to <u>Pin definitions</u>. 	Jun.15, 2023
1.9	<ol style="list-style-type: none"> 1. Add parameter note for table <u>Table 4-22. I/O port DC characteristics⁽¹⁾⁽³⁾</u>. 2. Update package outlines in <u>Package information</u>. 	Nov.30, 2023
2.0	<ol style="list-style-type: none"> 1. Descriptions of the first paragraph in <u>Electrical characteristics</u> modified. 2. Add coplanar information for all POD in <u>Package information</u>. 	Jun.3, 2024
2.1	<ol style="list-style-type: none"> 1. Add VREFP and VDPA related descriptions in <u>Electrical characteristics</u> chapter. 2. Change DAC to DAC0, change DAC_OUT0 to DAC0_OUT0 in <u>Memory map</u> and <u>Pin definitions</u>. 3. USART maximum frequency description modification, refer to <u>Universal synchronous asynchronous receiver transmitter (USART)</u>. 4. On-chip memory description modification, refer to <u>Device information</u> and <u>On-chip memory</u> chapters. 	Jan.10, 2025

Important Notice

This document is the property of GigaDevice Semiconductor Inc. and its subsidiaries (the "Company"). This document, including any product of the Company described in this document (the "Product"), is owned by the Company under the intellectual property laws and treaties of the People's Republic of China and other jurisdictions worldwide. The Company reserves all rights under such laws and treaties and does not grant any license under its patents, copyrights, trademarks, or other intellectual property rights. The names and brands of third party referred thereto (if any) are the property of their respective owner and referred to for identification purposes only.

The Company makes no warranty of any kind, express or implied, with regard to this document or any Product, including, but not limited to, the implied warranties of merchantability and fitness for a particular purpose. The Company does not assume any liability arising out of the application or use of any Product described in this document. Any information provided in this document is provided only for reference purposes. It is the responsibility of the user of this document to properly design, program, and test the functionality and safety of any application made of this information and any resulting product. Except for customized products which has been expressly identified in the applicable agreement, the Products are designed, developed, and/or manufactured for ordinary business, industrial, personal, and/or household applications only. The Products are not designed, intended, or authorized for use as components in systems designed or intended for the operation of weapons, weapons systems, nuclear installations, atomic energy control instruments, combustion control instruments, airplane or spaceship instruments, transportation instruments, traffic signal instruments, life-support devices or systems, other medical devices or systems (including resuscitation equipment and surgical implants), pollution control or hazardous substances management, or other uses where the failure of the device or Product could cause personal injury, death, property or environmental damage ("Unintended Uses"). Customers shall take any and all actions to ensure using and selling the Products in accordance with the applicable laws and regulations. The Company is not liable, in whole or in part, and customers shall and hereby do release the Company as well as its suppliers and/or distributors from any claim, damage, or other liability arising from or related to all Unintended Uses of the Products. Customers shall indemnify and hold the Company as well as its suppliers and/or distributors harmless from and against all claims, costs, damages, and other liabilities, including claims for personal injury or death, arising from or related to any Unintended Uses of the Products.

Information in this document is provided solely in connection with the Products. The Company reserves the right to make changes, corrections, modifications or improvements to this document and Products and services described herein at any time, without notice.