

GigaDevice Semiconductor Inc.

GD32F427xx

Arm[®] Cortex[®]-M4 32-bit MCU

Datasheet

Revision 1.8

(Dec. 2024)

Table of Contents

Table of Contents	1
List of Figures	4
List of Tables	5
1. General description	7
2. Device overview	8
2.1. Device information	8
2.2. Block diagram.....	11
2.3. Pinouts and pin assignment	12
2.4. Memory map	16
2.5. Clock tree	19
2.6. Pin definitions.....	20
2.6.1. GD32F427Ix BGA176 pin definitions.....	20
2.6.2. GD32F427Zx LQFP144 pin definitions.....	31
2.6.3. GD32F427Vx LQFP100 pin definitions	40
2.6.4. GD32F427Vx BGA100 pin definitions	48
2.6.5. GD32F427Rx LQFP64 pin definitions	55
2.6.6. GD32F427xx pin alternate functions	61
3. Functional description	71
3.1. Arm® Cortex®-M4 core	71
3.2. On-chip memory	71
3.3. Clock, reset and supply management.....	72
3.4. Boot modes.....	73
3.5. Power saving modes	73
3.6. Analog to digital converter (ADC)	73
3.7. Digital to analog converter (DAC).....	74
3.8. DMA.....	74
3.9. General-purpose inputs/outputs (GPIOs)	75
3.10. Timers and PWM generation	75
3.11. Real time clock (RTC) and backup registers	76
3.12. Inter-integrated circuit (I2C)	77
3.13. Serial peripheral interface (SPI)	77

3.14.	Universal synchronous/asynchronous receiver transmitter (USART/UART)	77
3.15.	Inter-IC sound (I2S)	78
3.16.	Universal serial bus full-speed interface (USBFS).....	78
3.17.	Universal serial bus high-speed interface (USBHS)	78
3.18.	Controller area network (CAN)	79
3.19.	Ethernet (ENET).....	79
3.20.	External memory controller (EXMC)	79
3.21.	Secure digital input and output card interface (SDIO).....	80
3.22.	Digital camera interface (DCI).....	80
3.23.	Debug mode	80
3.24.	Package and operation temperature.....	80
4.	Electrical characteristics.....	82
4.1.	Absolute maximum ratings.....	82
4.2.	Operating conditions characteristics.....	82
4.3.	Power consumption	84
4.4.	EMC characteristics	90
4.5.	Power supply supervisor characteristics	91
4.6.	Electrical sensitivity	92
4.7.	External clock characteristics	93
4.8.	Internal clock characteristics	95
4.9.	PLL characteristics.....	96
4.10.	Memory characteristics	98
4.11.	GPIO characteristics	99
4.12.	ADC characteristics	102
4.13.	Temperature sensor characteristics	103
4.14.	DAC characteristics	103
4.15.	I2C characteristics	104
4.16.	SPI characteristics	106
4.17.	I2S characteristics.....	108
4.18.	USART characteristics.....	110
4.19.	SDIO characteristics	110
4.20.	CAN characteristics	110

4.21.	USBFS characteristics	111
4.22.	USBHS characteristics	112
4.23.	Ethernet (ENET) characteristics.....	112
4.24.	EXMC characteristics.....	113
4.25.	TIMER characteristics.....	117
4.26.	DCI characteristics.....	117
4.27.	WDGT characteristics	118
4.28.	Parameter conditions.....	118
5.	Package information.....	119
5.1	BGA176 package outline dimensions	119
5.2	LQFP144 package outline dimensions.....	121
5.3	BGA100 package outline dimensions	123
5.4	LQFP100 package outline dimensions.....	125
5.5	LQFP64 package outline dimensions.....	127
5.6	Thermal characteristics	129
6.	Ordering information	131
7.	Revision history	132

List of Figures

Figure 2-1. GD32F427xx block diagram	11
Figure 2-2. GD32F427Ix BGA176 pinouts	12
Figure 2-3. GD32F427Vx BGA100 pinouts	13
Figure 2-4. GD32F427Zx LQFP144 pinouts.....	14
Figure 2-5. GD32F427Vx LQFP100 pinouts	15
Figure 2-6. GD32F427Rx LQFP64 pinouts	15
Figure 2-7. GD32F427xx clock tree	19
Figure 4-1. Recommended power supply decoupling capacitors ⁽¹⁾⁽²⁾	83
Figure 4-2. Typical supply current consumption in Run mode	89
Figure 4-3. Typical supply current consumption in Sleep mode.....	90
Figure 4-4. Recommended PDR_ON pin circuit.....	92
Figure 4-5. Recommended external NRST pin circuit ⁽¹⁾	99
Figure 4-6. I2C bus timing diagram.....	105
Figure 4-7. SPI timing diagram - master mode	106
Figure 4-8. SPI timing diagram - slave mode	107
Figure 4-9. I2S timing diagram - master mode.....	109
Figure 4-10. I2S timing diagram - slave mode.....	109
Figure 4-11. USBFS timings: definition of data signal rise and fall time	111
Figure 4-12. Ethernet SMI timing diagram	113
Figure 5-1. BGA176 package outline	119
Figure 5-2. BGA176 recommended footprint	120
Figure 5-3. LQFP144 package outline.....	121
Figure 5-4. LQFP144 recommended footprint.....	122
Figure 5-5. BGA100 package outline	123
Figure 5-6. BGA100 recommended footprint	124
Figure 5-7. LQFP100 package outline.....	125
Figure 5-8. LQFP100 recommended footprint.....	126
Figure 5-9. LQFP64 package outline.....	127
Figure 5-10. LQFP64 recommended footprint.....	128

List of Tables

Table 2-1. GD32F427xx devices features and peripheral list	8
Table 2-2. GD32F427xx devices features and peripheral list (Cont.)	9
Table 2-3. GD32F427xx memory map	16
Table 2-4. GD32F427Ix BGA176 pin definitions	20
Table 2-5. GD32F427Zx LQFP144 pin definitions	31
Table 2-6. GD32F427Vx LQFP100 pin definitions	40
Table 2-7. GD32F427Vx BGA100 pin definitions	48
Table 2-8. GD32F427Rx LQFP64 pin definitions	55
Table 2-9. Port A alternate functions summary	61
Table 2-10. Port B alternate functions summary	62
Table 2-11. Port C alternate functions summary	63
Table 2-12. Port D alternate functions summary	64
Table 2-13. Port E alternate functions summary	65
Table 2-14. Port F alternate functions summary	66
Table 2-15. Port G alternate functions summary	67
Table 2-16. Port H alternate functions summary	68
Table 2-17. Port I alternate functions summary	69
Table 4-1. Absolute maximum ratings ⁽¹⁾⁽⁴⁾	82
Table 4-2. DC operating conditions	82
Table 4-3. Clock frequency ⁽¹⁾	83
Table 4-4. Operating conditions at Power up / Power down ⁽¹⁾	83
Table 4-5. Start-up timings of Operating conditions ⁽¹⁾⁽²⁾⁽³⁾	83
Table 4-6. Power saving mode wakeup timings characteristics ⁽¹⁾⁽²⁾	84
Table 4-7. Power consumption characteristics ⁽²⁾⁽³⁾⁽⁴⁾⁽⁵⁾⁽⁶⁾	84
Table 4-8. EMS characteristics ⁽¹⁾	90
Table 4-9. EMI characteristics ⁽¹⁾	91
Table 4-10. Power supply supervisor characteristics	91
Table 4-11. ESD characteristics ⁽¹⁾	92
Table 4-12. Static latch-up characteristics ⁽¹⁾	93
Table 4-13. High speed external clock (HXTAL) generated from a crystal/ceramic characteristics ..	93
Table 4-14. High speed external clock characteristics (HXTAL in bypass mode)	93
Table 4-15. Low speed external clock (LXTAL) generated from a crystal/ceramic characteristics ..	94
Table 4-16. Low speed external user clock characteristics (LXTAL in bypass mode)	94
Table 4-17. High speed internal clock (IRC16M) characteristics	95
Table 4-18. High speed internal clock (IRC48M) characteristics	95
Table 4-19. Low speed internal clock (IRC32K) characteristics	96
Table 4-20. PLL characteristics	96
Table 4-21. PLLI2S characteristics	96
Table 4-22. PLLSAI characteristics	97
Table 4-23. PLL spread spectrum clock generation (SSCG) characteristics	97

Table 4-24. Flash memory characteristics ⁽¹⁾	98
Table 4-25. NRST pin characteristics	98
Table 4-26. I/O port DC characteristics ⁽¹⁾⁽³⁾	99
Table 4-27. I/O port AC characteristics ⁽¹⁾⁽²⁾⁽⁴⁾	101
Table 4-28. ADC characteristics	102
Table 4-29. ADC RAIN max for $f_{ADC} = 40 \text{ MHz}$ ⁽²⁾	102
Table 4-30. ADC dynamic accuracy at $f_{ADC} = 40 \text{ MHz}$ ⁽¹⁾	103
Table 4-31. ADC static accuracy at $f_{ADC} = 40 \text{ MHz}$ ⁽¹⁾	103
Table 4-32. Temperature sensor characteristics ⁽¹⁾	103
Table 4-33. DAC characteristics	103
Table 4-34. I2C characteristics ⁽¹⁾⁽²⁾	104
Table 4-35. Standard SPI characteristics ⁽¹⁾	106
Table 4-36. I2S characteristics ⁽¹⁾⁽²⁾	108
Table 4-37. USART characteristics ⁽¹⁾	110
Table 4-38. SDIO characteristics ⁽¹⁾⁽²⁾	110
Table 4-39. USBFS start up time.....	111
Table 4-40. USBFS DC electrical characteristics.....	111
Table 4-41. USBFS full speed-electrical characteristics ⁽¹⁾	111
Table 4-42. USBHS clock timing parameters ⁽¹⁾	112
Table 4-43. USB-ULPI Dynammic characteristics	112
Table 4-44. Dynamics characteristics: Ethernet MAC signals for SMI ⁽¹⁾	112
Table 4-45. Asynchronous non-multiplexed SRAM/PSRAM/NOR read timings ⁽¹⁾⁽²⁾⁽³⁾	113
Table 4-46. Asynchronous non-multiplexed SRAM/PSRAM/NOR write timings ⁽¹⁾⁽²⁾⁽³⁾	114
Table 4-47. Asynchronous multiplexed PSRAM/NOR read timings ⁽¹⁾⁽²⁾⁽³⁾	114
Table 4-48. Asynchronous multiplexed PSRAM/NOR write timings ⁽¹⁾⁽²⁾⁽³⁾	114
Table 4-49. Synchronous multiplexed PSRAM/NOR read timings ⁽¹⁾⁽²⁾⁽³⁾	115
Table 4-50. Synchronous multiplexed PSRAM write timings ⁽¹⁾⁽²⁾⁽³⁾	115
Table 4-51. Synchronous non-multiplexed PSRAM/NOR read timings ⁽¹⁾⁽²⁾⁽³⁾	116
Table 4-52. Synchronous non-multiplexed PSRAM write timings ⁽¹⁾⁽²⁾⁽³⁾	116
Table 4-53. TIMER characteristics ⁽¹⁾	117
Table 4-54. DCI characteristics ⁽¹⁾	117
Table 4-55. FWDGT min/max timeout period at 32 kHz (IRC32K) ⁽¹⁾	118
Table 4-56. WWDGT min-max timeout value at 50 MHz (f_{PCLK1}) ⁽¹⁾	118
Table 5-1. BGA176 package dimensions	119
Table 5-2. LQFP144 package dimensions.....	121
Table 5-3. BGA100 package dimensions	123
Table 5-4. LQFP100 package dimensions.....	125
Table 5-5. LQFP64 package dimensions.....	127
Table 5-6. Package thermal characteristics ⁽¹⁾	129
Table 6-1. Part ordering code for GD32F427xx devices.....	131
Table 7-1. Revision history	132

1. General description

The GD32F427xx device belongs to the connectivity line of GD32 MCU family. It is a new 32-bit general-purpose microcontroller based on the Arm® Cortex®-M4 RISC core with best cost-performance ratio in terms of enhanced processing capacity, reduced power consumption and peripheral set. The Cortex®-M4 core features a Floating Point Unit (FPU) that accelerates single precision floating point math operations and supports all Arm® single precision instructions and data types. It implements a full set of DSP instructions to address digital signal control markets that demand an efficient, easy-to-use blend of control and signal processing capabilities. It also provides a Memory Protection Unit (MPU) and powerful trace technology for enhanced application security and advanced debug support.

The GD32F427xx device incorporates the Arm® Cortex®-M4 32-bit processor core operating at 200 MHz frequency with Flash accesses zero wait states to obtain maximum efficiency. It provides up to 3072 KB on-chip Flash memory and 256 KB SRAM memory. An extensive range of enhanced I/Os and peripherals connected to two APB buses. The devices offer up to three 12-bit 2.6 MSPS ADCs, two 12-bit DACs, up to eight general 16-bit timers, two 16-bit PWM advanced timers, two 32-bit general timers, and two 16-bit basic timers, as well as standard and advanced communication interfaces: up to three SPIs, three I2Cs, four USARTs and two UARTs, two I2Ss, two CANs, a SDIO, USBFS and USBHS, and an ENET. Additional peripherals as Digital camera interface (DCI), EXMC interface with SDRAM extension support are included.

The device operates from a 2.6 to 3.6V power supply and available in –40 to +85 °C temperature range. Three power saving modes provide the flexibility for maximum optimization of power consumption, an especially important consideration in low power applications.

The above features make GD32F427xx devices suitable for a wide range of interconnection and advanced applications, especially in areas such as industrial control, consumer and handheld equipment, embedded modules, human machine interface, security and alarm systems, graphic display, automotive navigation, drone, IoT and so on.



2. Device overview

2.1. Device information

Table 2-1. GD32F427xx devices features and peripheral list

Part Number		GD32F427xx											
		RE	RG	RK	VE	VG	VK	VE	VG	VK	ZE	ZG	ZK
Flash	Code area (KB)	512	512	512	512	512	512	512	512	512	512	512	512
	Data area (KB)	0	512	2560	0	512	2560	0	512	2560	0	512	2560
	Total (KB)	512	1024	3072	512	1024	3072	512	1024	3072	512	1024	3072
SRAM (KB)		256	256	256	256	256	256	256	256	256	256	256	256
Timers	General timer(16-bit)	8 <small>(2-3, 8-13)</small>	8 <small>(2-3, 8-13)</small>	8 <small>(2-3, 8-13)</small>	8 <small>(2-3, 8-13)</small>	8 <small>(2-3, 8-13)</small>	8 <small>(2-3, 8-13)</small>	8 <small>(2-3, 8-13)</small>	8 <small>(2-3, 8-13)</small>	8 <small>(2-3, 8-13)</small>	8 <small>(2-3, 8-13)</small>	8 <small>(2-3, 8-13)</small>	8 <small>(2-3, 8-13)</small>
	General timer(32-bit)	2 <small>(1, 4)</small>	2 <small>(1, 4)</small>	2 <small>(1, 4)</small>	2 <small>(1, 4)</small>	2 <small>(1, 4)</small>	2 <small>(1, 4)</small>	2 <small>(1, 4)</small>	2 <small>(1, 4)</small>	2 <small>(1, 4)</small>	2 <small>(1, 4)</small>	2 <small>(1, 4)</small>	2 <small>(1, 4)</small>
	Advanced timer(16-bit)	2 <small>(0, 7)</small>	2 <small>(0, 7)</small>	2 <small>(0, 7)</small>	2 <small>(0, 7)</small>	2 <small>(0, 7)</small>	2 <small>(0, 7)</small>	2 <small>(0, 7)</small>	2 <small>(0, 7)</small>	2 <small>(0, 7)</small>	2 <small>(0, 7)</small>	2 <small>(0, 7)</small>	2 <small>(0, 7)</small>
	Basic timer(16-bit)	2 <small>(5, 6)</small>	2 <small>(5, 6)</small>	2 <small>(5, 6)</small>	2 <small>(5, 6)</small>	2 <small>(5, 6)</small>	2 <small>(5, 6)</small>	2 <small>(5, 6)</small>	2 <small>(5, 6)</small>	2 <small>(5, 6)</small>	2 <small>(5, 6)</small>	2 <small>(5, 6)</small>	2 <small>(5, 6)</small>
	SysTick	1	1	1	1	1	1	1	1	1	1	1	1
	Watchdog	2	2	2	2	2	2	2	2	2	2	2	2
	RTC	1	1	1	1	1	1	1	1	1	1	1	1
Connectivity	USART	4	4	4	4	4	4	4	4	4	4	4	4
	UART	2	2	2	2	2	2	2	2	2	2	2	2
	I2C	3	3	3	3	3	3	3	3	3	3	3	3
	SPI/I2S	3/2 <small>(0-2)/(1-2)</small>	3/2 <small>(0-2)/(1-2)</small>	3/2 <small>(0-2)/(1-2)</small>	3/2 <small>(0-2)/(1-2)</small>	3/2 <small>(0-2)/(1-2)</small>	3/2 <small>(0-2)/(1-2)</small>	3/2 <small>(0-2)/(1-2)</small>	3/2 <small>(0-2)/(1-2)</small>	3/2 <small>(0-2)/(1-2)</small>	3/2 <small>(0-2)/(1-2)</small>	3/2 <small>(0-2)/(1-2)</small>	3/2 <small>(0-2)/(1-2)</small>
	SDIO	1	1	1	1	1	1	1	1	1	1	1	1
	CAN	2	2	2	2	2	2	2	2	2	2	2	2
	USB	FS+H S	FS+H S	FS+H S	FS+H S	FS+H S	FS+H S	FS+H S	FS+H S	FS+H S	FS+H S	FS+H S	FS+H S
	ENET	1	1	1	1	1	1	1	1	1	1	1	1
	DCI	1	1	1	1	1	1	1	1	1	1	1	1
GPIO		51	51	51	82	82	82	82	82	82	114	114	114

Part Number		GD32F427xx											
		RE	RG	RK	VE	VG	VK	VE	VG	VK	ZE	ZG	ZK
EXMC/SDRAM		0/0	0/0	0/0	1/0	1/0	1/0	1/0	1/0	1/0	1/1	1/1	1/1
ADC(CHs)		3(16)	3(16)	3(16)	3(16)	3(16)	3(16)	3(16)	3(16)	3(16)	3(24)	3(24)	3(24)
DAC	Units	1	1	1	1	1	1	1	1	1	1	1	1
	Channels	2	2	2	2	2	2	2	2	2	2	2	2
Package		LQFP64			LQFP100			BGA100			LQFP144		

Table 2-2. GD32F427xx devices features and peripheral list (Cont.)

Part Number		GD32F427xx		
		IE	IG	IK
Flash	Code area (KB)	512	512	512
	Data area (KB)	0	512	2560
	Total (KB)	512	1024	3072
SRAM (KB)		256	256	256
Timers	General timer(16-bit)	8 <small>(2-3,8-13)</small>	8 <small>(2-3,8-13)</small>	8 <small>(2-3,8-13)</small>
	General timer(32-bit)	2 <small>(1,4)</small>	2 <small>(1,4)</small>	2 <small>(1,4)</small>
	Advanced timer(16-bit)	2 <small>(0,7)</small>	2 <small>(0,7)</small>	2 <small>(0,7)</small>
	Basic timer(16-bit)	2 <small>(5,6)</small>	2 <small>(5,6)</small>	2 <small>(5,6)</small>
	SysTick	1	1	1
	Watchdog	2	2	2
	RTC	1	1	1
Connectivity	USART	4	4	4
	UART	2	2	2
	I2C	3	3	3
	SPI/I2S	3/2 <small>(0-2)/(1-2)</small>	3/2 <small>(0-2)/(1-2)</small>	3/2 <small>(0-2)/(1-2)</small>
	SDIO	1	1	1
	CAN	2	2	2
	USB	FS+HS	FS+HS	FS+HS
	ENET	1	1	1
DCI	1	1	1	

Part Number		GD32F427xx		
		IE	IG	IK
GPIO		140	140	140
EXMC/SDRAM		1/1	1/1	1/1
ADC(CHs)		3(24)	3(24)	3(24)
DAC	Units	1	1	1
	Channels	2	2	2
Package		BGA176		

2.2. Block diagram

Figure 2-1. GD32F427xx block diagram

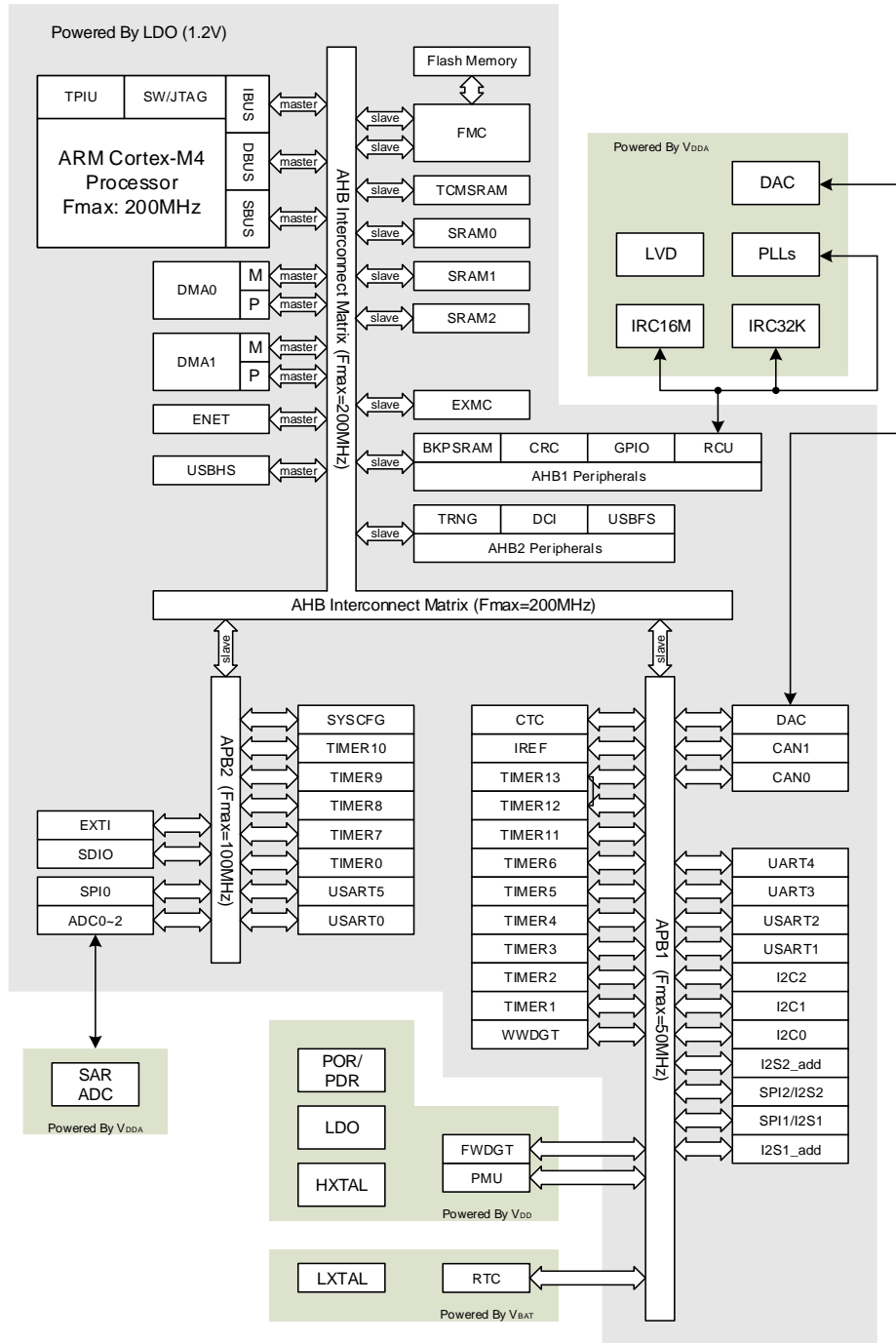

2.3. Pinouts and pin assignment

Figure 2-2. GD32F427Ix BGA176 pinouts

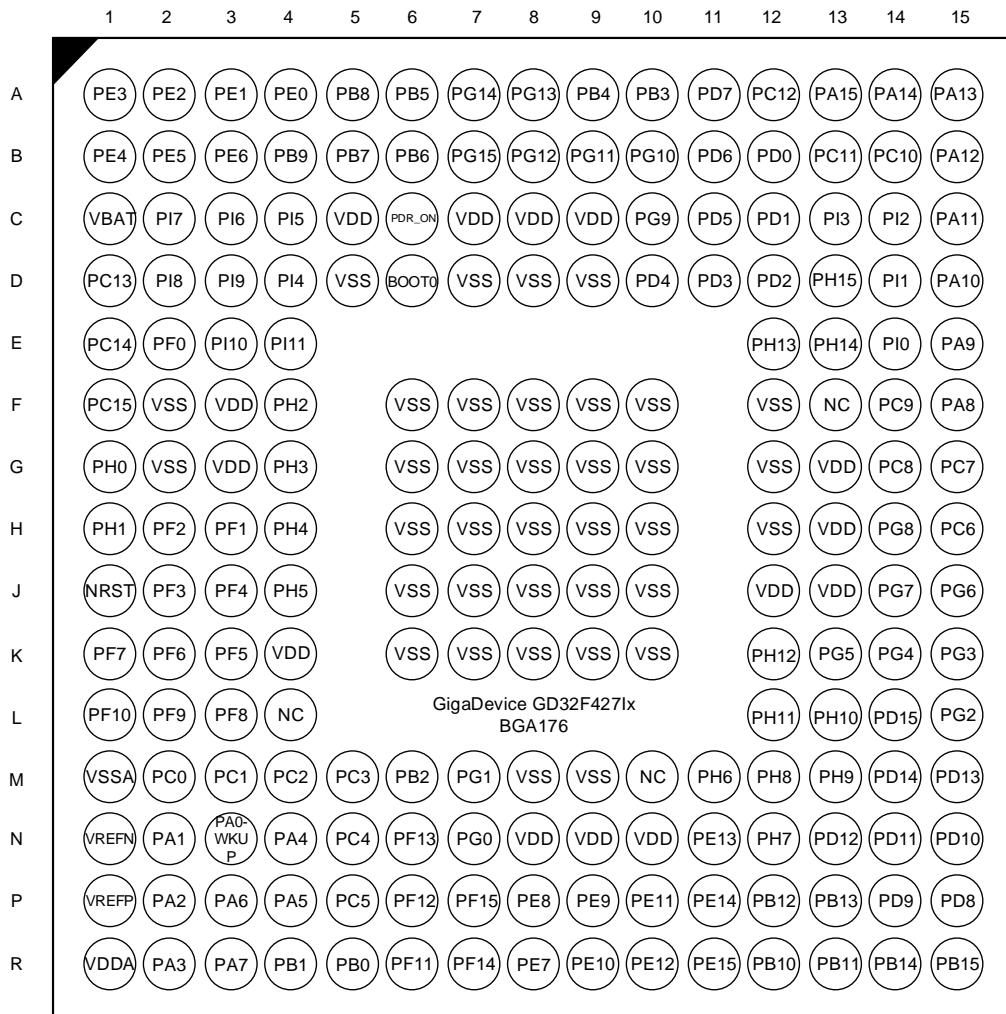

Figure 2-3. GD32F427Vx BGA100 pinouts



Figure 2-4. GD32F427Zx LQFP144 pinouts

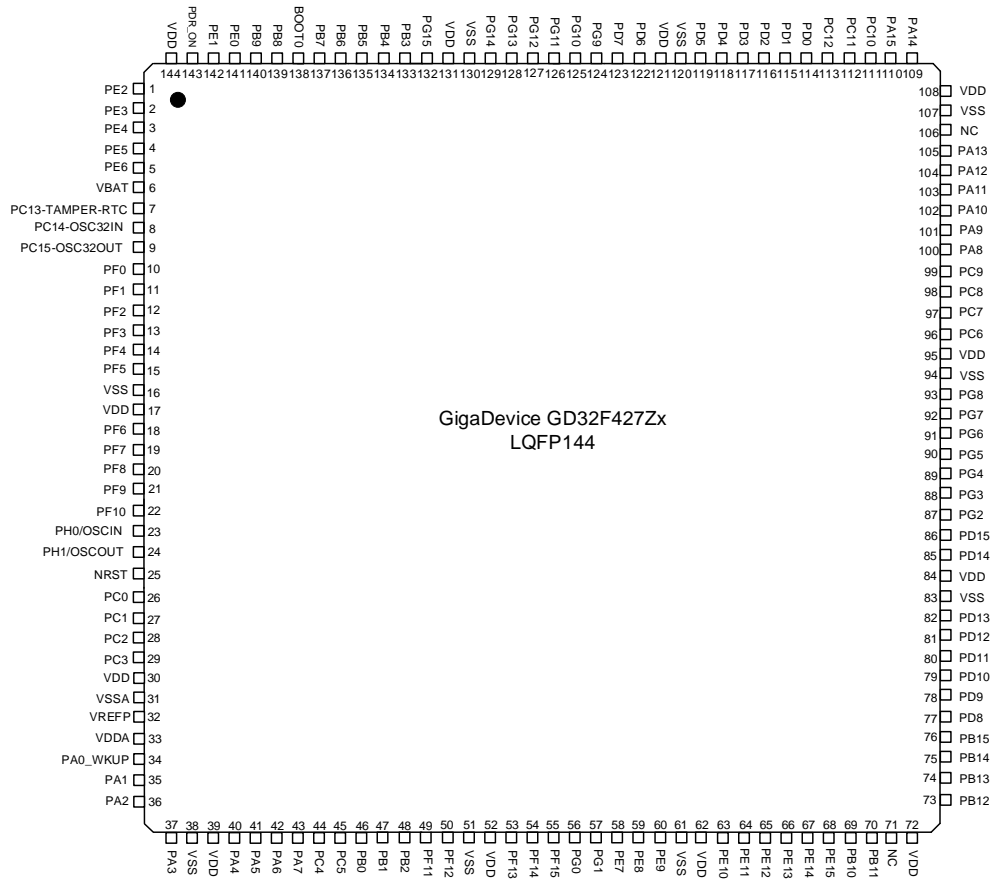

Figure 2-5. GD32F427Vx LQFP100 pinouts

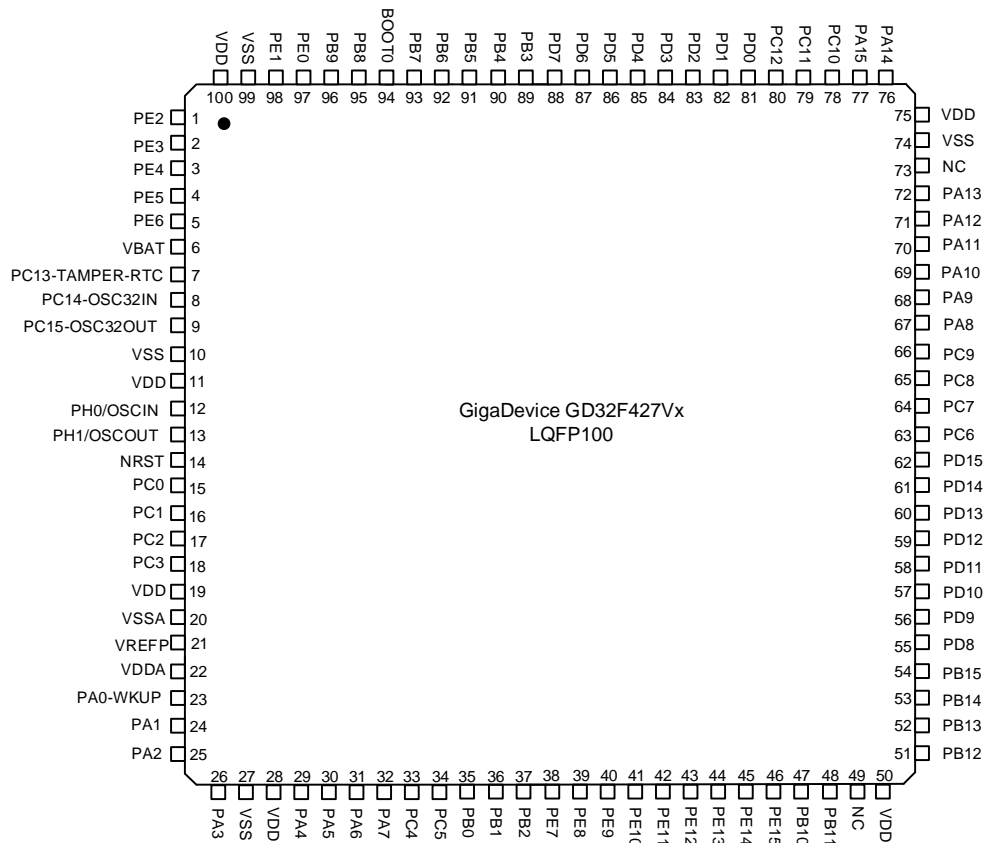
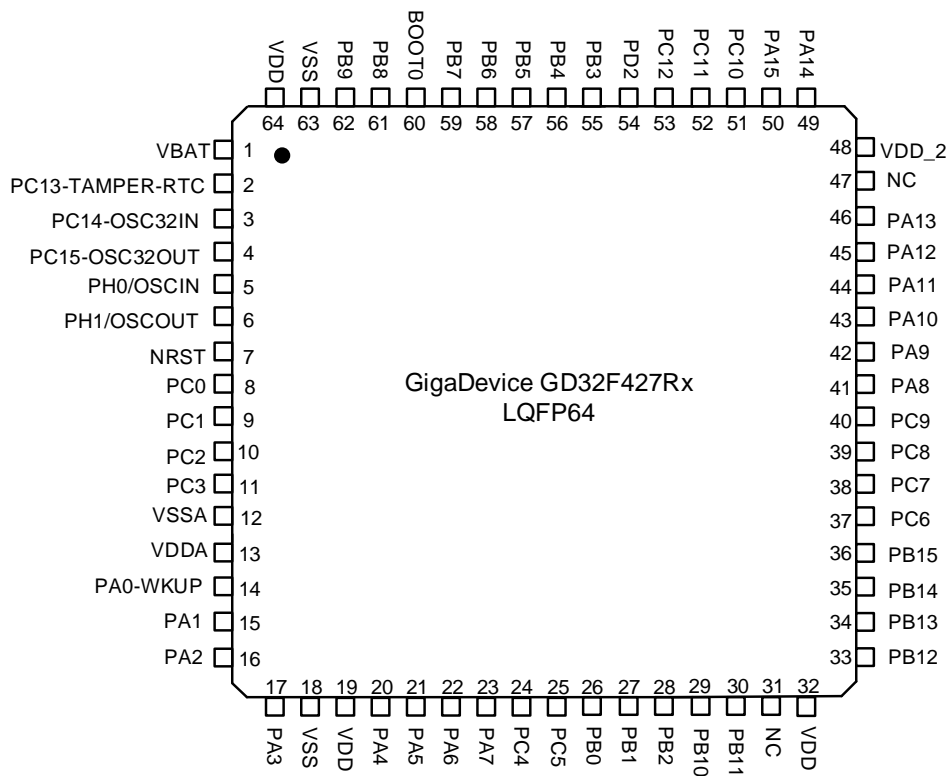

Figure 2-6. GD32F427Rx LQFP64 pinouts



2.4. Memory map

Table 2-3. GD32F427xx memory map

Pre-defined Regions	Bus	Address	Peripherals
External Device	AHB	0xC000 0000 - 0xDFFF FFFF	EXMC - SDRAM
		0xA000 1000 - 0xBFFF FFFF	Reserved
		0xA000 0000 - 0xA000 0FFF	EXMC - SWREG
		0x9000 0000 - 0x9FFF FFFF	EXMC - PC CARD
		0x7000 0000 - 0x8FFF FFFF	EXMC - NAND
		0x6000 0000 - 0x6FFF FFFF	EXMC - NOR/PSRAM/SRAM
External RAM	AHB	0x5006 0C00 - 0x5FFF FFFF	Reserved
		0x5006 0800 - 0x5006 0BFF	TRNG
		0x5005 0400 - 0x5006 07FF	Reserved
		0x5005 0000 - 0x5005 03FF	DCI
		0x5004 0000 - 0x5004 FFFF	Reserved
		0x5000 0000 - 0x5003 FFFF	USBFS
Peripheral	AHB2	0x4008 0000 - 0x4FFF FFFF	Reserved
		0x4004 0000 - 0x4007 FFFF	USBHS
		0x4002 BC00 - 0x4003 FFFF	Reserved
		0x4002 B000 - 0x4002 BBFF	Reserved
		0x4002 A000 - 0x4002 AFFF	Reserved
		0x4002 8000 - 0x4002 9FFF	ENET
	AHB1	0x4002 6800 - 0x4002 7FFF	Reserved
		0x4002 6400 - 0x4002 67FF	DMA1
		0x4002 6000 - 0x4002 63FF	DMA0
		0x4002 5000 - 0x4002 5FFF	Reserved
		0x4002 4000 - 0x4002 4FFF	BKP SRAM
		0x4002 3C00 - 0x4002 3FFF	FMC
		0x4002 3800 - 0x4002 3BFF	RCU
		0x4002 3400 - 0x4002 37FF	Reserved
		0x4002 3000 - 0x4002 33FF	CRC
		0x4002 2400 - 0x4002 2FFF	Reserved
		0x4002 2000 - 0x4002 23FF	GPIOI
		0x4002 1C00 - 0x4002 1FFF	GPIOH
		0x4002 1800 - 0x4002 1BFF	GPIOG
		0x4002 1400 - 0x4002 17FF	GPIOF
		0x4002 1000 - 0x4002 13FF	GPIOE
		0x4002 0C00 - 0x4002 0FFF	GPIOD
		0x4002 0800 - 0x4002 0BFF	GPIOC
		0x4002 0400 - 0x4002 07FF	GPIOB
		0x4002 0000 - 0x4002 03FF	GPIOA

Pre-defined Regions	Bus	Address	Peripherals
	APB2	0x4001 6C00 - 0x4001 FFFF	Reserved
		0x4001 6800 - 0x4001 6BFF	Reserved
		0x4001 5800 - 0x4001 67FF	Reserved
		0x4001 5400 - 0x4001 57FF	Reserved
		0x4001 5000 - 0x4001 53FF	Reserved
		0x4001 4C00 - 0x4001 4FFF	Reserved
		0x4001 4800 - 0x4001 4BFF	TIMER10
		0x4001 4400 - 0x4001 47FF	TIMER9
		0x4001 4000 - 0x4001 43FF	TIMER8
		0x4001 3C00 - 0x4001 3FFF	EXTI
		0x4001 3800 - 0x4001 3BFF	SYSCFG
		0x4001 3400 - 0x4001 37FF	Reserved
		0x4001 3000 - 0x4001 33FF	SPI0
		0x4001 2C00 - 0x4001 2FFF	SDIO
		0x4001 2400 - 0x4001 2BFF	Reserved
		0x4001 2300 - 0x4001 23FF	ADC0 ⁽¹⁾
		0x4001 2200 - 0x4001 22FF	ADC2
		0x4001 2100 - 0x4001 21FF	ADC1
		0x4001 2000 - 0x4001 20FF	ADC0
		0x4001 1800 - 0x4001 1FFF	Reserved
		0x4001 1400 - 0x4001 17FF	USART5
		0x4001 1000 - 0x4001 13FF	USART0
		0x4001 0800 - 0x4001 0FFF	Reserved
		0x4001 0400 - 0x4001 07FF	TIMER7
	0x4001 0000 - 0x4001 03FF	TIMER0	
	APB1	0x4000 C800 - 0x4000 FFFF	Reserved
		0x4000 C400 - 0x4000 C7FF	IREF
		0x4000 8000 - 0x4000 C3FF	Reserved
		0x4000 7C00 - 0x4000 7FFF	Reserved
		0x4000 7800 - 0x4000 7BFF	Reserved
		0x4000 7400 - 0x4000 77FF	DAC0
		0x4000 7000 - 0x4000 73FF	PMU
		0x4000 6C00 - 0x4000 6FFF	CTC
		0x4000 6800 - 0x4000 6BFF	CAN1
		0x4000 6400 - 0x4000 67FF	CAN0
		0x4000 6000 - 0x4000 63FF	Reserved
0x4000 5C00 - 0x4000 5FFF		I2C2	
0x4000 5800 - 0x4000 5BFF	I2C1		
0x4000 5400 - 0x4000 57FF	I2C0		
0x4000 5000 - 0x4000 53FF	UART4		

Pre-defined Regions	Bus	Address	Peripherals
		0x4000 4C00 - 0x4000 4FFF	UART3
		0x4000 4800 - 0x4000 4BFF	USART2
		0x4000 4400 - 0x4000 47FF	USART1
		0x4000 4000 - 0x4000 43FF	I2S2_add
		0x4000 3C00 - 0x4000 3FFF	SPI2/I2S2
		0x4000 3800 - 0x4000 3BFF	SPI1/I2S1
		0x4000 3400 - 0x4000 37FF	I2S1_add
		0x4000 3000 - 0x4000 33FF	FWDGT
		0x4000 2C00 - 0x4000 2FFF	WWDGT
		0x4000 2800 - 0x4000 2BFF	RTC
		0x4000 2400 - 0x4000 27FF	Reserved
		0x4000 2000 - 0x4000 23FF	TIMER13
		0x4000 1C00 - 0x4000 1FFF	TIMER12
		0x4000 1800 - 0x4000 1BFF	TIMER11
		0x4000 1400 - 0x4000 17FF	TIMER6
		0x4000 1000 - 0x4000 13FF	TIMER5
		0x4000 0C00 - 0x4000 0FFF	TIMER4
		0x4000 0800 - 0x4000 0BFF	TIMER3
		0x4000 0400 - 0x4000 07FF	TIMER2
		0x4000 0000 - 0x4000 03FF	TIMER1
SRAM	AHB	0x2007 0000 - 0x3FFF FFFF	Reserved
		0x2003 0000 - 0x2006 FFFF	Reserved
		0x2002 0000 - 0x2002 FFFF	SRAM2(64KB)
		0x2001 C000 - 0x2001 FFFF	SRAM1(16KB)
		0x2000 0000 - 0x2001 BFFF	SRAM0(112KB)
Code	AHB	0x1FFF C010 - 0x1FFF FFFF	Reserved
		0x1FFF C000 - 0x1FFF C00F	Option bytes(Bank 0)
		0x1FFF 7A10 - 0x1FFF BFFF	Reserved
		0x1FFF 7800 - 0x1FFF 7A0F	OTP(512B)
		0x1FFF 0000 - 0x1FFF 77FF	Boot loader(30KB)
		0x1FFE C010 - 0x1FFE FFFF	Reserved
		0x1FFE C000 - 0x1FFE C00F	Option bytes(Bank 1)
		0x1001 0000 - 0x1FFE BFFF	Reserved
		0x1000 0000 - 0x1000 FFFF	TCMSRAM(64KB)
		0x0830 0000 - 0x0FFF FFFF	Reserved
		0x0800 0000 - 0x082F FFFF	Main Flash(3072KB)
		0x0000 0000 - 0x07FF FFFF	Aliased to the boot device

Note:

(1) ADC_SSTAT, ADC_SYNCCTL, ADC_SYNCDATA based on base address of ADC0.

2.5. Clock tree

Figure 2-7. GD32F427xx clock tree

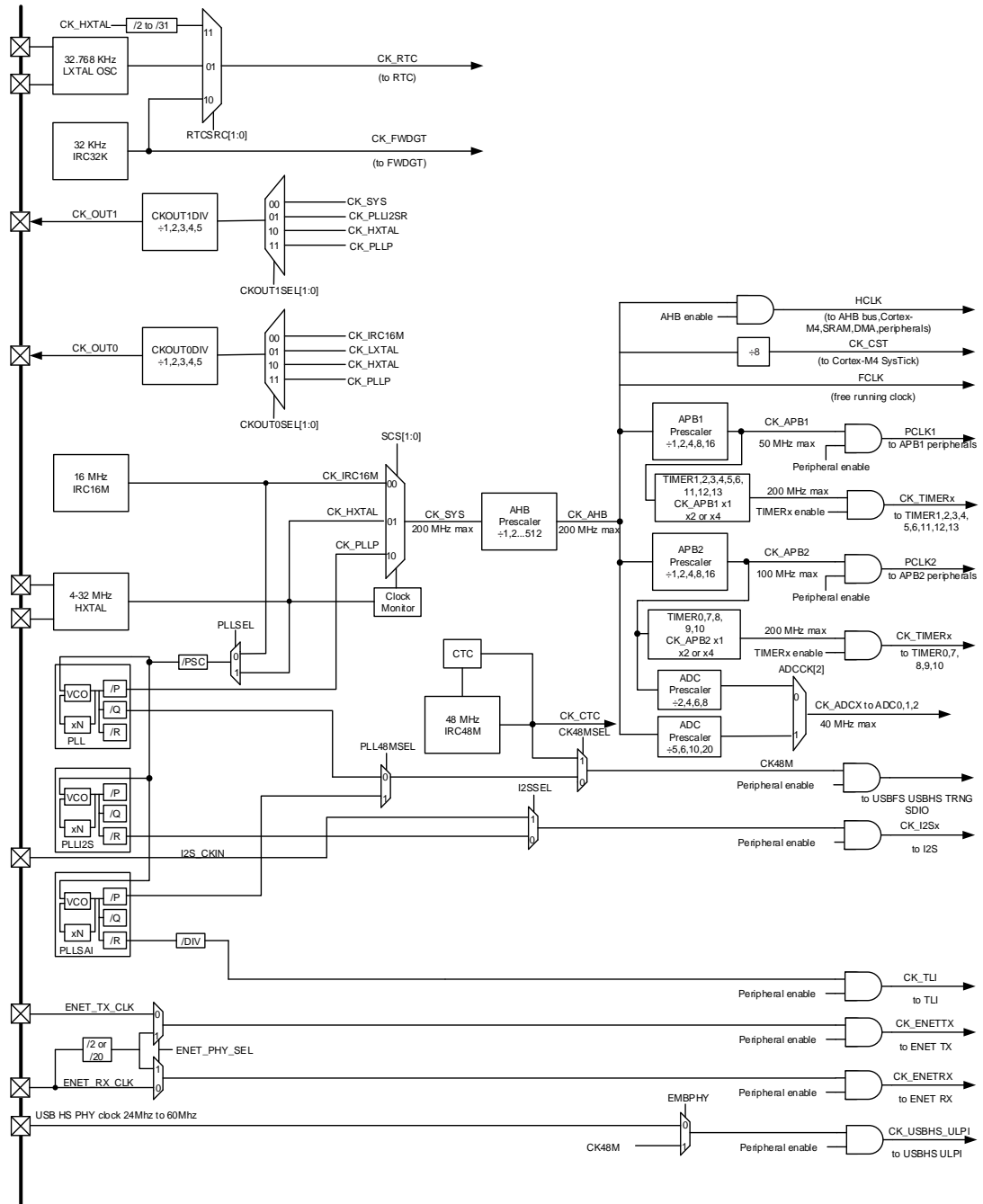

Legend:

- HXTAL: High speed crystal oscillator
- LXTAL: Low speed crystal oscillator
- IRC16M: Internal 16M RC oscillators
- IRC32K: Internal 32K RC oscillator
- IRC48M: Internal 48M RC oscillators

2.6. Pin definitions

2.6.1. GD32F427Ix BGA176 pin definitions

Table 2-4. GD32F427Ix BGA176 pin definitions

GD32F427Ix BGA176				
Pin Name	Pins	Pin Type ⁽¹⁾	I/O Level ⁽²⁾	Functions description
PE2	A2	I/O	5VT	Default: PE2 Alternate: ENET_MII_TXD3, EXMC_A23, EVENTOUT
PE3	A1	I/O	5VT	Default: PE3 Alternate: EXMC_A19, EVENTOUT
PE4	B1	I/O	5VT	Default: PE4 Alternate: EXMC_A20, DCI_D4, EVENTOUT
PE5	B2	I/O	5VT	Default: PE5 Alternate: TIMER8_CH0, EXMC_A21, DCI_D6, EVENTOUT
PE6	B3	I/O	5VT	Default: PE6 Alternate: TIMER8_CH1, EXMC_A22, DCI_D7, EVENTOUT
VBAT	C1	P	-	Default: VBAT
PI8	D2	I/O	5VT	Default: PI8 Alternate: EVENTOUT Additional: RTC_TAMP1, RTC_TAMP0, RTC_TS
PC13- TAMPER- RTC	D1	I/O	5VT	Default: PC13 Alternate: EVENTOUT Additional: RTC_TAMP0, RTC_OUT, RTC_TS
PC14- OSC32IN	E1	I/O	5VT	Default: PC14 Alternate: EVENTOUT Additional: OSC32IN
PC15- OSC32O UT	F1	I/O	5VT	Default: PC15 Alternate: EVENTOUT Additional: OSC32OUT
PI9	D3	I/O	5VT	Default: PI9 Alternate: CAN0_RX, EXMC_D30, EVENTOUT
PI10	E3	I/O	5VT	Default: PI10 Alternate: ENET_MII_RX_ER, EXMC_D31, EVENTOUT
PI11	E4	I/O	5VT	Default: PI11 Alternate: USBHS_ULPI_DIR, EVENTOUT
VSS	F2	P	-	Default: VSS
VDD	F3	P	-	Default: VDD
PF0	E2	I/O	5VT	Default: PF0 Alternate: I2C1_SDA, EXMC_A0, EVENTOUT, CTC_SYNC
PF1	H3	I/O	5VT	Default: PF1

GD32F4271x BGA176				
Pin Name	Pins	Pin Type ⁽¹⁾	I/O Level ⁽²⁾	Functions description
				Alternate: I2C1_SCL, EXMC_A1, EVENTOUT
PF2	H2	I/O	5VT	Default: PF2 Alternate: I2C1_SMBA, EXMC_A2, EVENTOUT
PF3	J2	I/O	5VT	Default: PF3 Alternate: EXMC_A3, EVENTOUT, I2C1_TXFRAME Additional: ADC2_IN9
PF4	J3	I/O	5VT	Default: PF4 Alternate: EXMC_A4, EVENTOUT Additional: ADC2_IN14
PF5	K3	I/O	5VT	Default: PF5 Alternate: EXMC_A5, EVENTOUT Additional: ADC2_IN15
VSS	G2	P	-	Default: VSS
VDD	G3	P	-	Default: VDD
PF6	K2	I/O	5VT	Default: PF6 Alternate: TIMER9_CH0, EXMC_NIORD, EVENTOUT Additional: ADC2_IN4
PF7	K1	I/O	5VT	Default: PF7 Alternate: TIMER10_CH0, EXMC_NREG, EVENTOUT Additional: ADC2_IN5
PF8	L3	I/O	5VT	Default: PF8 Alternate: TIMER12_CH0, EXMC_NIOWR, EVENTOUT Additional: ADC2_IN6
PF9	L2	I/O	5VT	Default: PF9 Alternate: TIMER13_CH0, EXMC_CD, EVENTOUT Additional: ADC2_IN7
PF10	L1	I/O	5VT	Default: PF10 Alternate: EXMC_INTR, DCI_D11, EVENTOUT Additional: ADC2_IN8
PH0/OSCIN	G1	I/O	5VT	Default: PH0, OSCIN Alternate: EVENTOUT Additional: OSCIN
PH1/OSCOUT	H1	I/O	5VT	Default: PH1, OSCOUT Alternate: EVENTOUT Additional: OSCOUT
NRST	J1	-	-	Default: NRST
PC0	M2	I/O	5VT	Default: PC0 Alternate: USBHS_ULPI_STP, EXMC_SDNWE, EVENTOUT Additional: ADC012_IN10
PC1	M3	I/O	5VT	Default: PC1

GD32F4271x BGA176				
Pin Name	Pins	Pin Type ⁽¹⁾	I/O Level ⁽²⁾	Functions description
				Alternate: SPI2_MOSI, I2S2_SD, SPI1_MOSI, I2S1_SD, ENET_MDC, EVENTOUT Additional: ADC012_IN11
PC2	M4	I/O	5VT	Default: PC2 Alternate: SPI1_MISO, I2S1_ADD_SD, USBHS_ULPI_DIR, ENET_MII_TXD2, EXMC_SDNE0, EVENTOUT Additional: ADC012_IN12
PC3	M5	I/O	5VT	Default: PC3 Alternate: SPI1_MOSI, I2S1_SD, USBHS_ULPI_NXT, ENET_MII_TX_CLK, EXMC_SDCKE0, EVENTOUT Additional: ADC012_IN13
VSSA	M1	P	-	Default: VSSA
VREFN	N1	P	-	Default: VREFN
VREFP	P1	P	-	Default: VREFP
VDDA	R1	P	-	Default: VDDA
PA0-WKUP	N3	I/O	5VT	Default: PA0 Alternate: TIMER1_CH0, TIMER1_ETI, TIMER4_CH0, TIMER7_ETI, USART1_CTS, UART3_TX, ENET_MII_CRS, EVENTOUT Additional: ADC012_IN0, WKUP
PA1	N2	I/O	5VT	Default: PA1 Alternate: TIMER1_CH1, TIMER4_CH1, USART1_RTS, UART3_RX, ENET_MII_RX_CLK, ENET_RMII_REF_CLK, EVENTOUT Additional: ADC012_IN1
PA2	P2	I/O	5VT	Default: PA2 Alternate: TIMER1_CH2, TIMER4_CH2, TIMER8_CH0, I2S_CKIN, USART1_TX, ENET_MDIO, EVENTOUT Additional: ADC012_IN2
PH2	F4	I/O	5VT	Default: PH2 Alternate: ENET_MII_CRS, EXMC_SDCKE0, EVENTOUT
PH3	G4	I/O	5VT	Default: PH3 Alternate: ENET_MII_COL, EXMC_SDNE0, EVENTOUT, I2C1_TXFRAME
PH4	H4	I/O	5VT	Default: PH4 Alternate: I2C1_SCL, USBHS_ULPI_NXT, EVENTOUT
PH5	J4	I/O	5VT	Default: PH5 Alternate: I2C1_SDA, EXMC_SDNWE, EVENTOUT
PA3	R2	I/O	5VT	Default: PA3 Alternate: TIMER1_CH3, TIMER4_CH3, TIMER8_CH1,

GD32F4271x BGA176				
Pin Name	Pins	Pin Type ⁽¹⁾	I/O Level ⁽²⁾	Functions description
				I2S1_MCK, USART1_RX, USBHS_ULPI_D0, ENET_MII_COL, EVENTOUT Additional: ADC012_IN3
NC	L4	-	-	-
VDD	K4	P	-	Default: VDD
PA4	N4	I/O		Default: PA4 Alternate: SPI0_NSS, SPI2_NSS, I2S2_WS, USART1_CK, USBHS_SOF, DCI_HSYNC, EVENTOUT Additional: ADC01_IN4, DAC0_OUT0
PA5	P4	I/O		Default: PA5 Alternate: TIMER1_CH0, TIMER1_ETI, TIMER7_CH0_ON, SPI0_SCK, USBHS_ULPI_CK, EVENTOUT Additional: ADC01_IN5, DAC0_OUT1
PA6	P3	I/O	5VT	Default: PA6 Alternate: TIMER0_BRKIN, TIMER2_CH0, TIMER7_BRKIN, SPI0_MISO, I2S1_MCK, TIMER12_CH0, SDIO_CMD, DCI_PIXCLK, EVENTOUT Additional: ADC01_IN6
PA7	R3	I/O	5VT	Default: PA7 Alternate: TIMER0_CH0_ON, TIMER2_CH1, TIMER7_CH0_ON, SPI0_MOSI, TIMER13_CH0, ENET_MII_RX_DV, ENET_RMII_CRS_DV, EXMC_SDNWE, EVENTOUT Additional: ADC01_IN7
PC4	N5	I/O	5VT	Default: PC4 Alternate: ENET_MII_RXD0, ENET_RMII_RXD0, EXMC_SDNE0, EVENTOUT Additional: ADC01_IN14
PC5	P5	I/O	5VT	Default: PC5 Alternate: USART2_RX, ENET_MII_RXD1, ENET_RMII_RXD1, EXMC_SDCKE0, EVENTOUT Additional: ADC01_IN15
PB0	R5	I/O	5VT	Default: PB0 Alternate: TIMER0_CH1_ON, TIMER2_CH2, TIMER7_CH1_ON, SPI2_MOSI, I2S2_SD, USBHS_ULPI_D1, ENET_MII_RXD2, SDIO_D1, EVENTOUT Additional: ADC01_IN8, IREF
PB1	R4	I/O	5VT	Default: PB1 Alternate: TIMER0_CH2_ON, TIMER2_CH3,

GD32F4271x BGA176				
Pin Name	Pins	Pin Type ⁽¹⁾	I/O Level ⁽²⁾	Functions description
				TIMER7_CH2_ON, USBHS_ULPI_D2, ENET_MII_RXD3, SDIO_D2, EVENTOUT Additional: ADC01_IN9
PB2	M6	I/O	5VT	Default: PB2, BOOT1 Alternate: TIMER1_CH3, SPI2_MOSI, I2S2_SD, USBHS_ULPI_D4, SDIO_CK, EVENTOUT
PF11	R6	I/O	5VT	Default: PF11 Alternate: EXMC_SDNRAS, DCI_D12, EVENTOUT
PF12	P6	I/O	5VT	Default: PF12 Alternate: EXMC_A6, EVENTOUT
VSS	M8	P	-	Default: VSS
VDD	N8	P	-	Default: VDD
PF13	N6	I/O	5VT	Default: PF13 Alternate: EXMC_A7, EVENTOUT
PF14	R7	I/O	5VT	Default: PF14 Alternate: EXMC_A8, EVENTOUT
PF15	P7	I/O	5VT	Default: PF15 Alternate: EXMC_A9, EVENTOUT
PG0	N7	I/O	5VT	Default: PG0 Alternate: EXMC_A10, EVENTOUT
PG1	M7	I/O	5VT	Default: PG1 Alternate: EXMC_A11, EVENTOUT
PE7	R8	I/O	5VT	Default: PE7 Alternate: TIMER0_ETI, EXMC_D4, EVENTOUT
PE8	P8	I/O	5VT	Default: PE8 Alternate: TIMER0_CH0_ON, EXMC_D5, EVENTOUT
PE9	P9	I/O	5VT	Default: PE9 Alternate: TIMER0_CH0, EXMC_D6, EVENTOUT
VSS	M9	P	-	Default: VSS
VDD	N9	P	-	Default: VDD
PE10	R9	I/O	5VT	Default: PE10 Alternate: TIMER0_CH1_ON, EXMC_D7, EVENTOUT
PE11	P10	I/O	5VT	Default: PE11 Alternate: TIMER0_CH1, EXMC_D8, EVENTOUT
PE12	R10	I/O	5VT	Default: PE12 Alternate: TIMER0_CH2_ON, EXMC_D9, EVENTOUT
PE13	N11	I/O	5VT	Default: PE13 Alternate: TIMER0_CH2, EXMC_D10, EVENTOUT
PE14	P11	I/O	5VT	Default: PE14 Alternate: TIMER0_CH3, EXMC_D11, EVENTOUT

GD32F4271x BGA176				
Pin Name	Pins	Pin Type ⁽¹⁾	I/O Level ⁽²⁾	Functions description
PE15	R11	I/O	5VT	Default: PE15 Alternate: TIMER0_BRKIN, EXMC_D12, EVENTOUT
PB10	R12	I/O	5VT	Default: PB10 Alternate: TIMER1_CH2, I2C1_SCL, SPI1_SCK, I2S1_CK, I2S2_MCK, USART2_TX, USBHS_ULPI_D3, ENET_MII_RX_ER, SDIO_D7, EVENTOUT
PB11	R13	I/O	5VT	Default: PB11 Alternate: TIMER1_CH3, I2C1_SDA, I2S_CKIN, USART2_RX, USBHS_ULPI_D4, ENET_MII_TX_EN, ENET_RMII_TX_EN, EVENTOUT
NC	M10	-	-	-
VDD	N10	P	-	Default: VDD
PH6	M11	I/O	5VT	Default: PH6 Alternate: I2C1_SMBA, TIMER11_CH0, ENET_MII_RXD2, EXMC_SDNE1, DCI_D8, EVENTOUT
PH7	N12	I/O	5VT	Default: PH7 Alternate: I2C2_SCL, ENET_MII_RXD3, EXMC_SDCKE1, DCI_D9, EVENTOUT
PH8	M12	I/O	5VT	Default: PH8 Alternate: I2C2_SDA, EXMC_D16, DCI_HSYNC, EVENTOUT
PH9	M13	I/O	5VT	Default: PH9 Alternate: I2C2_SMBA, TIMER11_CH1, EXMC_D17, DCI_D0, EVENTOUT
PH10	L13	I/O	5VT	Default: PH10 Alternate: TIMER4_CH0, EXMC_D18, DCI_D1, EVENTOUT, I2C2_TXFRAME
PH11	L12	I/O	5VT	Default: PH11 Alternate: TIMER4_CH1, EXMC_D19, DCI_D2, EVENTOUT
PH12	K12	I/O	5VT	Default: PH12 Alternate: TIMER4_CH2, EXMC_D20, DCI_D3, EVENTOUT
VSS	H12	P	-	Default: VSS
VDD	J12	P	-	Default: VDD
PB12	P12	I/O	5VT	Default: PB12 Alternate: TIMER0_BRKIN, I2C1_SMBA, SPI1_NSS, I2S1_WS, USART2_CK, CAN1_RX, USBHS_ULPI_D5, ENET_MII_TXD0, ENET_RMII_TXD0, USBHS_ID, EVENTOUT
PB13	P13	I/O	5VT	Default: PB13 Alternate: TIMER0_CH0_ON, SPI1_SCK, I2S1_CK,

GD32F427xx BGA176				
Pin Name	Pins	Pin Type ⁽¹⁾	I/O Level ⁽²⁾	Functions description
				USART2_CTS, CAN1_TX, USBHS_ULPI_D6, ENET_MII_TXD1, ENET_RMII_TXD1, EVENTOUT, I2C1_TXFRAME Additional: USBHS_VBUS
PB14	R14	I/O	5VT	Default: PB14 Alternate: TIMER0_CH1_ON, TIMER7_CH1_ON, SPI1_MISO, I2S1_ADD_SD, USART2_RTS, TIMER11_CH0, USBHS_DM, EVENTOUT
PB15	R15	I/O	5VT	Default: PB15 Alternate: RTC_REFIN, TIMER0_CH2_ON, TIMER7_CH2_ON, SPI1_MOSI, I2S1_SD, TIMER11_CH1, USBHS_DP, EVENTOUT
PD8	P15	I/O	5VT	Default: PD8 Alternate: USART2_TX, EXMC_D13, EVENTOUT
PD9	P14	I/O	5VT	Default: PD9 Alternate: USART2_RX, EXMC_D14, EVENTOUT
PD10	N15	I/O	5VT	Default: PD10 Alternate: USART2_CK, EXMC_D15, EVENTOUT
PD11	N14	I/O	5VT	Default: PD11 Alternate: USART2_CTS, EXMC_A16/EXMC_CLE, EVENTOUT
PD12	N13	I/O	5VT	Default: PD12 Alternate: TIMER3_CH0, USART2_RTS, EXMC_A17/EXMC_ALE, EVENTOUT
PD13	M15	I/O	5VT	Default: PD13 Alternate: TIMER3_CH1, EXMC_A18, EVENTOUT
VDD	J13	P	-	Default: VDD
PD14	M14	I/O	5VT	Default: PD14 Alternate: TIMER3_CH2, EXMC_D0, EVENTOUT
PD15	L14	I/O	5VT	Default: PD15 Alternate: TIMER3_CH3, EXMC_D1, EVENTOUT, CTC_SYNC
PG2	L15	I/O	5VT	Default: PG2 Alternate: EXMC_A12, EVENTOUT
PG3	K15	I/O	5VT	Default: PG3 Alternate: EXMC_A13, EVENTOUT
PG4	K14	I/O	5VT	Default: PG4 Alternate: EXMC_A14, EVENTOUT
PG5	K13	I/O	5VT	Default: PG5 Alternate: EXMC_A15, EVENTOUT

GD32F4271x BGA176				
Pin Name	Pins	Pin Type ⁽¹⁾	I/O Level ⁽²⁾	Functions description
PG6	J15	I/O	5VT	Default: PG6 Alternate: EXMC_INT1, DCI_D12, EVENTOUT
PG7	J14	I/O	5VT	Default: PG7 Alternate: USART5_CK, EXMC_INT2, DCI_D13, EVENTOUT
PG8	H14	I/O	5VT	Default: PG8 Alternate: USART5_RTS, ENET_PPS_OUT, EXMC_SDCLK, EVENTOUT
VSS	G12	P	-	Default: VSS
VDD	H13	P	-	Default: VDD
PC6	H15	I/O	5VT	Default: PC6 Alternate: TIMER2_CH0, TIMER7_CH0, I2S1_MCK, USART5_TX, SDIO_D6, DCI_D0, EVENTOUT
PC7	G15	I/O	5VT	Default: PC7 Alternate: TIMER2_CH1, TIMER7_CH1, SPI1_SCK, I2S1_CK, I2S2_MCK, USART5_RX, SDIO_D7, DCI_D1, EVENTOUT
PC8	G14	I/O	5VT	Default: PC8 Alternate: TIMER2_CH2, TIMER7_CH2, USART5_CK, SDIO_D0, DCI_D2, EVENTOUT
PC9	F14	I/O	5VT	Default: PC9 Alternate: CK_OUT1, TIMER2_CH3, TIMER7_CH3, I2C2_SDA, I2S_CKIN, SDIO_D1, DCI_D3, EVENTOUT
PA8	F15	I/O	5VT	Default: PA8 Alternate: CK_OUT0, TIMER0_CH0, I2C2_SCL, USART0_CK, USBFS_SOF, SDIO_D1, EVENTOUT, CTC_SYNC
PA9	E15	I/O	5VT	Default: PA9 Alternate: TIMER0_CH1, I2C2_SMBA, SPI1_SCK, I2S1_CK, USART0_TX, SDIO_D2, DCI_D0, EVENTOUT Additional: USBFS_VBUS
PA10	D15	I/O	5VT	Default: PA10 Alternate: TIMER0_CH2, USART0_RX, USBFS_ID, DCI_D1, EVENTOUT, I2C2_TXFRAME
PA11	C15	I/O	5VT	Default: PA11 Alternate: TIMER0_CH3, USART0_CTS, USART5_TX, CAN0_RX, USBFS_DM, EVENTOUT
PA12	B15	I/O	5VT	Default: PA12 Alternate: TIMER0_ETI, USART0_RTS, USART5_RX, CAN0_TX, USBFS_DP, EVENTOUT

GD32F4271x BGA176				
Pin Name	Pins	Pin Type ⁽¹⁾	I/O Level ⁽²⁾	Functions description
PA13	A15	I/O	5VT	Default: JTMS, SWDIO, PA13 Alternate: EVENTOUT
NC	F13	-	-	-
VSS	F12	P	-	Default: VSS
VDD	G13	P	-	Default: VDD
PH13	E12	I/O	5VT	Default: PH13 Alternate: TIMER7_CH0_ON, CAN0_TX, EXMC_D21, EVENTOUT
PH14	E13	I/O	5VT	Default: PH14 Alternate: TIMER7_CH1_ON, EXMC_D22, DCI_D4, EVENTOUT
PH15	D13	I/O	5VT	Default: PH15 Alternate: TIMER7_CH2_ON, EXMC_D23, DCI_D11, EVENTOUT
PI0	E14	I/O	5VT	Default: PI0 Alternate: TIMER4_CH3, SPI1_NSS, I2S1_WS, EXMC_D24, DCI_D13, EVENTOUT
PI1	D14	I/O	5VT	Default: PI1 Alternate: SPI1_SCK, I2S1_CK, EXMC_D25, DCI_D8, EVENTOUT
PI2	C14	I/O	5VT	Default: PI2 Alternate: TIMER7_CH3, SPI1_MISO, I2S1_ADD_SD, EXMC_D26, DCI_D9, EVENTOUT
PI3	C13	I/O	5VT	Default: PI3 Alternate: TIMER7_ETI, SPI1_MOSI, I2S1_SD, EXMC_D27, DCI_D10, EVENTOUT
VSS	D9	P	-	Default: VSS
VDD	C9	P	-	Default: VDD
PA14	A14	I/O	5VT	Default: JTCK, SWCLK, PA14 Alternate: EVENTOUT
PA15	A13	I/O	5VT	Default: JTDI, PA15 Alternate: TIMER1_CH0, TIMER1_ETI, SPI0_NSS, SPI2_NSS, I2S2_WS, USART0_TX, EVENTOUT
PC10	B14	I/O	5VT	Default: PC10 Alternate: SPI2_SCK, I2S2_CK, USART2_TX, UART3_TX, SDIO_D2, DCI_D8, EVENTOUT
PC11	B13	I/O	5VT	Default: PC11 Alternate: I2S2_ADD_SD, SPI2_MISO, USART2_RX, UART3_RX, SDIO_D3, DCI_D4, EVENTOUT
PC12	A12	I/O	5VT	Default: PC12

GD32F427xx BGA176				
Pin Name	Pins	Pin Type ⁽¹⁾	I/O Level ⁽²⁾	Functions description
				Alternate: I2C1_SDA, SPI2_MOSI, I2S2_SD, USART2_CK, UART4_TX, SDIO_CK, DCI_D9, EVENTOUT
PD0	B12	I/O	5VT	Default: PD0 Alternate: SPI2_MOSI, I2S2_SD, CAN0_RX, EXMC_D2, EVENTOUT
PD1	C12	I/O	5VT	Default: PD1 Alternate: SPI1_NSS, I2S1_WS, CAN0_TX, EXMC_D3, EVENTOUT
PD2	D12	I/O	5VT	Default: PD2 Alternate: TIMER2_ETI, UART4_RX, SDIO_CMD, DCI_D11, EVENTOUT
PD3	D11	I/O	5VT	Default: PD3 Alternate: SPI1_SCK, I2S1_CK, USART1_CTS, EXMC_CLK, DCI_D5, EVENTOUT
PD4	D10	I/O	5VT	Default: PD4 Alternate: USART1_RTS, EXMC_NOE, EVENTOUT
PD5	C11	I/O	5VT	Default: PD5 Alternate: USART1_TX, EXMC_NWE, EVENTOUT
VSS	D8	P	-	Default: VSS
VDD	C8	P	-	Default: VDD
PD6	B11	I/O	5VT	Default: PD6 Alternate: SPI2_MOSI, I2S2_SD, USART1_RX, EXMC_NWAIT, DCI_D10, EVENTOUT
PD7	A11	I/O	5VT	Default: PD7 Alternate: USART1_CK, EXMC_NE0, EXMC_NCE1, EVENTOUT
PG9	C10	I/O	5VT	Default: PG9 Alternate: USART5_RX, EXMC_NE1, EXMC_NCE2, DCI_VSYNC, EVENTOUT
PG10	B10	I/O	5VT	Default: PG10 Alternate: EXMC_NCE3_0, EXMC_NE2, DCI_D2, EVENTOUT
PG11	B9	I/O	5VT	Default: PG11 Alternate: ENET_MII_TX_EN, ENET_RMII_TX_EN, EXMC_NCE3_1, DCI_D3, EVENTOUT
PG12	B8	I/O	5VT	Default: PG12 Alternate: USART5_RTS, EXMC_NE3, EVENTOUT
PG13	A8	I/O	5VT	Default: PG13 Alternate: USART5_CTS, ENET_MII_TXD0, ENET_RMII_TXD0, EXMC_A24, EVENTOUT

GD32F4271x BGA176				
Pin Name	Pins	Pin Type ⁽¹⁾	I/O Level ⁽²⁾	Functions description
PG14	A7	I/O	5VT	Default: PG14 Alternate: USART5_TX, ENET_MII_TXD1, ENET_RMII_TXD1, EXMC_A25, EVENTOUT
VSS	D7	P	-	Default: VSS
VDD	C7	P	-	Default: VDD
PG15	B7	I/O	5VT	Default: PG15 Alternate: USART5_CTS, EXMC_SDNCAS, DCI_D13, EVENTOUT
PB3	A10	I/O	5VT	Default: JTDO, PB3 Alternate: TRACESWO, TIMER1_CH1, SPI0_SCK, SPI2_SCK, I2S2_CK, USART0_RX, I2C1_SDA, EVENTOUT
PB4	A9	I/O	5VT	Default: NJTRST, PB4 Alternate: TIMER2_CH0, SPI0_MISO, SPI2_MISO, I2S2_ADD_SD, I2C2_SDA, SDIO_D0, EVENTOUT, I2C0_TXFRAME
PB5	A6	I/O	5VT	Default: PB5 Alternate: TIMER2_CH1, I2C0_SMBA, SPI0_MOSI, SPI2_MOSI, I2S2_SD, CAN1_RX, USBHS_ULPI_D7, ENET_PPS_OUT, EXMC_SDCKE1, DCI_D10, EVENTOUT
PB6	B6	I/O	5VT	Default: PB6 Alternate: TIMER3_CH0, I2C0_SCL, USART0_TX, CAN1_TX, EXMC_SDNE1, DCI_D5, EVENTOUT
PB7	B5	I/O	5VT	Default: PB7 Alternate: TIMER3_CH1, I2C0_SDA, USART0_RX, EXMC_NL/EXMC_NADV, DCI_VSYNC, EVENTOUT
BOOT0	D6	I/O	5VT	Default: BOOT0
PB8	A5	I/O	5VT	Default: PB8 Alternate: TIMER1_CH0, TIMER1_ETI, TIMER3_CH2, TIMER9_CH0, I2C0_SCL, CAN0_RX, ENET_MII_TXD3, SDIO_D4, DCI_D6, EVENTOUT
PB9	B4	I/O	5VT	Default: PB9 Alternate: TIMER1_CH1, TIMER3_CH3, TIMER10_CH0, I2C0_SDA, SPI1_NSS, I2S1_WS, CAN0_TX, SDIO_D5, DCI_D7, EVENTOUT
PE0	A4	I/O	5VT	Default: PE0 Alternate: TIMER3_ETI, EXMC_NBL0, DCI_D2, EVENTOUT
PE1	A3	I/O	5VT	Default: PE1 Alternate: TIMER0_CH1_ON, EXMC_NBL1, DCI_D3, EVENTOUT
VSS	D5	P	-	Default: VSS

GD32F4271x BGA176				
Pin Name	Pins	Pin Type ⁽¹⁾	I/O Level ⁽²⁾	Functions description
PDR_ON	C6	P	-	Default: PDR_ON
VDD	C5	P	-	Default: VDD
PI4	D4	I/O	5VT	Default: PI4 Alternate: TIMER7_BRKIN, EXMC_NBL2, DCI_D5, EVENTOUT
PI5	C4	I/O	5VT	Default: PI5 Alternate: TIMER7_CH0, EXMC_NBL3, DCI_VSYNC, EVENTOUT
PI6	C3	I/O	5VT	Default: PI6 Alternate: TIMER7_CH1, EXMC_D28, DCI_D6, EVENTOUT
PI7	C2	I/O	5VT	Default: PI7 Alternate: TIMER7_CH2, EXMC_D29, DCI_D7, EVENTOUT

Notes:

(1) Type: I = input, O = output, P = power.

(2) I/O Level: 5VT = 5 V tolerant.

2.6.2. GD32F427Zx LQFP144 pin definitions

Table 2-5. GD32F427Zx LQFP144 pin definitions

GD32F427Zx LQFP144				
Pin Name	Pins	Pin Type ⁽¹⁾	I/O Level ⁽²⁾	Functions description
PE2	1	I/O	5VT	Default: PE2 Alternate: ENET_MII_TXD3, EXMC_A23, EVENTOUT
PE3	2	I/O	5VT	Default: PE3 Alternate: EXMC_A19, EVENTOUT
PE4	3	I/O	5VT	Default: PE4 Alternate: EXMC_A20, DCI_D4, EVENTOUT
PE5	4	I/O	5VT	Default: PE5 Alternate: TIMER8_CH0, EXMC_A21, DCI_D6, EVENTOUT
PE6	5	I/O	5VT	Default: PE6 Alternate: TIMER8_CH1, EXMC_A22, DCI_D7, EVENTOUT
VBAT	6	P	-	Default: VBAT
PC13- TAMPER- RTC	7	I/O	5VT	Default: PC13 Alternate: EVENTOUT Additional: RTC_TAMP0, RTC_OUT, RTC_TS
PC14- OSC32IN	8	I/O	5VT	Default: PC14 Alternate: EVENTOUT Additional: OSC32IN
PC15-	9	I/O	5VT	Default: PC15

GD32F427Zx LQFP144				
Pin Name	Pins	Pin Type ⁽¹⁾	I/O Level ⁽²⁾	Functions description
OSC32OUT				Alternate: EVENTOUT Additional: OSC32OUT
PF0	10	I/O	5VT	Default: PF0 Alternate: I2C1_SDA, EXMC_A0, EVENTOUT, CTC_SYNC
PF1	11	I/O	5VT	Default: PF1 Alternate: I2C1_SCL, EXMC_A1, EVENTOUT
PF2	12	I/O	5VT	Default: PF2 Alternate: I2C1_SMBA, EXMC_A2, EVENTOUT
PF3	13	I/O	5VT	Default: PF3 Alternate: EXMC_A3, EVENTOUT, I2C1_TXFRAME Additional: ADC2_IN9
PF4	14	I/O	5VT	Default: PF4 Alternate: EXMC_A4, EVENTOUT Additional: ADC2_IN14
PF5	15	I/O	5VT	Default: PF5 Alternate: EXMC_A5, EVENTOUT Additional: ADC2_IN15
VSS	16	P	-	Default: VSS
VDD	17	P	-	Default: VDD
PF6	18	I/O	5VT	Default: PF6 Alternate: TIMER9_CH0, EXMC_NIORD, EVENTOUT Additional: ADC2_IN4
PF7	19	I/O	5VT	Default: PF7 Alternate: TIMER10_CH0, EXMC_NREG, EVENTOUT Additional: ADC2_IN5
PF8	20	I/O	5VT	Default: PF8 Alternate: TIMER12_CH0, EXMC_NIOWR, EVENTOUT Additional: ADC2_IN6
PF9	21	I/O	5VT	Default: PF9 Alternate: TIMER13_CH0, EXMC_CD, EVENTOUT Additional: ADC2_IN7
PF10	22	I/O	5VT	Default: PF10 Alternate: EXMC_INTR, DCI_D11, EVENTOUT Additional: ADC2_IN8
PH0/OSCIN	23	I/O	5VT	Default: PH0, OSCIN Alternate: EVENTOUT Additional: OSCIN
PH1/OSCOU	24	I/O	5VT	Default: PH1, OSCOUT Alternate: EVENTOUT Additional: OSCOUT

GD32F427Zx LQFP144				
Pin Name	Pins	Pin Type ⁽¹⁾	I/O Level ⁽²⁾	Functions description
NRST	25	-	-	Default: NRST
PC0	26	I/O	5VT	Default: PC0 Alternate: USBHS_ULPI_STP, EXMC_SDNWE, EVENTOUT Additional: ADC012_IN10
PC1	27	I/O	5VT	Default: PC1 Alternate: SPI2_MOSI, I2S2_SD, SPI1_MOSI, I2S1_SD, ENET_MDC, EVENTOUT Additional: ADC012_IN11
PC2	28	I/O	5VT	Default: PC2 Alternate: SPI1_MISO, I2S1_ADD_SD, USBHS_ULPI_DIR, ENET_MII_TXD2, EXMC_SDNE0, EVENTOUT Additional: ADC012_IN12
PC3	29	I/O	5VT	Default: PC3 Alternate: SPI1_MOSI, I2S1_SD, USBHS_ULPI_NXT, ENET_MII_TX_CLK, EXMC_SDCKE0, EVENTOUT Additional: ADC012_IN13
VDD	30	P	-	Default: VDD
VSSA	31	P	-	Default: VSSA
VREFP	32	P	-	Default: VREFP
VDDA	33	P	-	Default: VDDA
PA0-WKUP	34	I/O	5VT	Default: PA0 Alternate: TIMER1_CH0, TIMER1_ETI, TIMER4_CH0, TIMER7_ETI, USART1_CTS, UART3_TX, ENET_MII_CRS, EVENTOUT Additional: ADC012_IN0, WKUP
PA1	35	I/O	5VT	Default: PA1 Alternate: TIMER1_CH1, TIMER4_CH1, USART1_RTS, UART3_RX, ENET_MII_RX_CLK, ENET_RMII_REF_CLK, EVENTOUT Additional: ADC012_IN1
PA2	36	I/O	5VT	Default: PA2 Alternate: TIMER1_CH2, TIMER4_CH2, TIMER8_CH0, I2S_CKIN, USART1_TX, ENET_MDIO, EVENTOUT Additional: ADC012_IN2
PA3	37	I/O	5VT	Default: PA3 Alternate: TIMER1_CH3, TIMER4_CH3, TIMER8_CH1, I2S1_MCK, USART1_RX, USBHS_ULPI_D0, ENET_MII_COL, EVENTOUT Additional: ADC012_IN3
VSS	38	P	-	Default: VSS

GD32F427Zx LQFP144				
Pin Name	Pins	Pin Type ⁽¹⁾	I/O Level ⁽²⁾	Functions description
VDD	39	P	-	Default: VDD
PA4	40	I/O		Default: PA4 Alternate: SPI0_NSS, SPI2_NSS, I2S2_WS, USART1_CK, USBHS_SOF, DCI_HSYNC, EVENTOUT Additional: ADC01_IN4, DAC0_OUT0
PA5	41	I/O		Default: PA5 Alternate: TIMER1_CH0, TIMER1_ETI, TIMER7_CH0_ON, SPI0_SCK, USBHS_ULPI_CK, EVENTOUT Additional: ADC01_IN5, DAC0_OUT1
PA6	42	I/O	5VT	Default: PA6 Alternate: TIMER0_BRKIN, TIMER2_CH0, TIMER7_BRKIN, SPI0_MISO, I2S1_MCK, TIMER12_CH0, SDIO_CMD, DCI_PIXCLK, EVENTOUT Additional: ADC01_IN6
PA7	43	I/O	5VT	Default: PA7 Alternate: TIMER0_CH0_ON, TIMER2_CH1, TIMER7_CH0_ON, SPI0_MOSI, TIMER13_CH0, ENET_MII_RX_DV, ENET_RMII_CRS_DV, EXMC_SDNWE, EVENTOUT Additional: ADC01_IN7
PC4	44	I/O	5VT	Default: PC4 Alternate: ENET_MII_RXD0, ENET_RMII_RXD0, EXMC_SDNE0, EVENTOUT Additional: ADC01_IN14
PC5	45	I/O	5VT	Default: PC5 Alternate: USART2_RX, ENET_MII_RXD1, ENET_RMII_RXD1, EXMC_SDCKE0, EVENTOUT Additional: ADC01_IN15
PB0	46	I/O	5VT	Default: PB0 Alternate: TIMER0_CH1_ON, TIMER2_CH2, TIMER7_CH1_ON, SPI2_MOSI, I2S2_SD, USBHS_ULPI_D1, ENET_MII_RXD2, SDIO_D1, EVENTOUT Additional: ADC01_IN8, IREF
PB1	47	I/O	5VT	Default: PB1 Alternate: TIMER0_CH2_ON, TIMER2_CH3, TIMER7_CH2_ON, USBHS_ULPI_D2, ENET_MII_RXD3, SDIO_D2, EVENTOUT Additional: ADC01_IN9
PB2	48	I/O	5VT	Default: PB2, BOOT1 Alternate: TIMER1_CH3, SPI2_MOSI, I2S2_SD, USBHS_ULPI_D4, SDIO_CK, EVENTOUT
PF11	49	I/O	5VT	Default: PF11

GD32F427Zx LQFP144				
Pin Name	Pins	Pin Type ⁽¹⁾	I/O Level ⁽²⁾	Functions description
				Alternate: EXMC_SDNRAS, DCI_D12, EVENTOUT
PF12	50	I/O	5VT	Default: PF12 Alternate: EXMC_A6, EVENTOUT
VSS	51	P	-	Default: VSS
VDD	52	P	-	Default: VDD
PF13	53	I/O	5VT	Default: PF13 Alternate: EXMC_A7, EVENTOUT
PF14	54	I/O	5VT	Default: PF14 Alternate: EXMC_A8, EVENTOUT
PF15	55	I/O	5VT	Default: PF15 Alternate: EXMC_A9, EVENTOUT
PG0	56	I/O	5VT	Default: PG0 Alternate: EXMC_A10, EVENTOUT
PG1	57	I/O	5VT	Default: PG1 Alternate: EXMC_A11, EVENTOUT
PE7	58	I/O	5VT	Default: PE7 Alternate: TIMER0_ETI, EXMC_D4, EVENTOUT
PE8	59	I/O	5VT	Default: PE8 Alternate: TIMER0_CH0_ON, EXMC_D5, EVENTOUT
PE9	60	I/O	5VT	Default: PE9 Alternate: TIMER0_CH0, EXMC_D6, EVENTOUT
VSS	61	P	-	Default: VSS
VDD	62	P	-	Default: VDD
PE10	63	I/O	5VT	Default: PE10 Alternate: TIMER0_CH1_ON, EXMC_D7, EVENTOUT
PE11	64	I/O	5VT	Default: PE11 Alternate: TIMER0_CH1, EXMC_D8, EVENTOUT
PE12	65	I/O	5VT	Default: PE12 Alternate: TIMER0_CH2_ON, EXMC_D9, EVENTOUT
PE13	66	I/O	5VT	Default: PE13 Alternate: TIMER0_CH2, EXMC_D10, EVENTOUT
PE14	67	I/O	5VT	Default: PE14 Alternate: TIMER0_CH3, EXMC_D11, EVENTOUT
PE15	68	I/O	5VT	Default: PE15 Alternate: TIMER0_BRKIN, EXMC_D12, EVENTOUT
PB10	69	I/O	5VT	Default: PB10 Alternate: TIMER1_CH2, I2C1_SCL, SPI1_SCK, I2S1_CK, I2S2_MCK, USART2_TX, USBHS_ULPI_D3, ENET_MII_RX_ER, SDIO_D7, EVENTOUT
PB11	70	I/O	5VT	Default: PB11

GD32F427Zx LQFP144				
Pin Name	Pins	Pin Type ⁽¹⁾	I/O Level ⁽²⁾	Functions description
				Alternate: TIMER1_CH3, I2C1_SDA, I2S_CKIN, USART2_RX, USBHS_ULPI_D4, ENET_MII_TX_EN, ENET_RMII_TX_EN, EVENTOUT
NC	71	-	-	-
VDD	72	P	-	Default: VDD
PB12	73	I/O	5VT	Default: PB12 Alternate: TIMER0_BRKIN, I2C1_SMBA, SPI1_NSS, I2S1_WS, USART2_CK, CAN1_RX, USBHS_ULPI_D5, ENET_MII_TXD0, ENET_RMII_TXD0, USBHS_ID, EVENTOUT
PB13	74	I/O	5VT	Default: PB13 Alternate: TIMER0_CH0_ON, SPI1_SCK, I2S1_CK, USART2_CTS, CAN1_TX, USBHS_ULPI_D6, ENET_MII_TXD1, ENET_RMII_TXD1, EVENTOUT, I2C1_TXFRAME Additional: USBHS_VBUS
PB14	75	I/O	5VT	Default: PB14 Alternate: TIMER0_CH1_ON, TIMER7_CH1_ON, SPI1_MISO, I2S1_ADD_SD, USART2_RTS, TIMER11_CH0, USBHS_DM, EVENTOUT
PB15	76	I/O	5VT	Default: PB15 Alternate: RTC_REFIN, TIMER0_CH2_ON, TIMER7_CH2_ON, SPI1_MOSI, I2S1_SD, TIMER11_CH1, USBHS_DP, EVENTOUT
PD8	77	I/O	5VT	Default: PD8 Alternate: USART2_TX, EXMC_D13, EVENTOUT
PD9	78	I/O	5VT	Default: PD9 Alternate: USART2_RX, EXMC_D14, EVENTOUT
PD10	79	I/O	5VT	Default: PD10 Alternate: USART2_CK, EXMC_D15, EVENTOUT
PD11	80	I/O	5VT	Default: PD11 Alternate: USART2_CTS, EXMC_A16/EXMC_CLE, EVENTOUT
PD12	81	I/O	5VT	Default: PD12 Alternate: TIMER3_CH0, USART2_RTS, EXMC_A17/EXMC_ALE, EVENTOUT
PD13	82	I/O	5VT	Default: PD13 Alternate: TIMER3_CH1, EXMC_A18, EVENTOUT
VSS	83	P	-	Default: VSS
VDD	84	P	-	Default: VDD
PD14	85	I/O	5VT	Default: PD14 Alternate: TIMER3_CH2, EXMC_D0, EVENTOUT
PD15	86	I/O	5VT	Default: PD15 Alternate: TIMER3_CH3, EXMC_D1, EVENTOUT, CTC_SYNC

GD32F427Zx LQFP144				
Pin Name	Pins	Pin Type ⁽¹⁾	I/O Level ⁽²⁾	Functions description
PG2	87	I/O	5VT	Default: PG2 Alternate: EXMC_A12, EVENTOUT
PG3	88	I/O	5VT	Default: PG3 Alternate: EXMC_A13, EVENTOUT
PG4	89	I/O	5VT	Default: PG4 Alternate: EXMC_A14, EVENTOUT
PG5	90	I/O	5VT	Default: PG5 Alternate: EXMC_A15, EVENTOUT
PG6	91	I/O	5VT	Default: PG6 Alternate: EXMC_INT1, DCI_D12, EVENTOUT
PG7	92	I/O	5VT	Default: PG7 Alternate: USART5_CK, EXMC_INT2, DCI_D13, EVENTOUT
PG8	93	I/O	5VT	Default: PG8 Alternate: USART5_RTS, ENET_PPS_OUT, EXMC_SDCLK, EVENTOUT
VSS	94	P	-	Default: VSS
VDD	95	P	-	Default: VDD
PC6	96	I/O	5VT	Default: PC6 Alternate: TIMER2_CH0, TIMER7_CH0, I2S1_MCK, USART5_TX, SDIO_D6, DCI_D0, EVENTOUT
PC7	97	I/O	5VT	Default: PC7 Alternate: TIMER2_CH1, TIMER7_CH1, SPI1_SCK, I2S1_CK, I2S2_MCK, USART5_RX, SDIO_D7, DCI_D1, EVENTOUT
PC8	98	I/O	5VT	Default: PC8 Alternate: TIMER2_CH2, TIMER7_CH2, USART5_CK, SDIO_D0, DCI_D2, EVENTOUT
PC9	99	I/O	5VT	Default: PC9 Alternate: CK_OUT1, TIMER2_CH3, TIMER7_CH3, I2C2_SDA, I2S_CKIN, SDIO_D1, DCI_D3, EVENTOUT
PA8	100	I/O	5VT	Default: PA8 Alternate: CK_OUT0, TIMER0_CH0, I2C2_SCL, USART0_CK, USBFS_SOF, SDIO_D1, EVENTOUT, CTC_SYNC
PA9	101	I/O	5VT	Default: PA9 Alternate: TIMER0_CH1, I2C2_SMBA, SPI1_SCK, I2S1_CK, USART0_TX, SDIO_D2, DCI_D0, EVENTOUT Additional: USBFS_VBUS
PA10	102	I/O	5VT	Default: PA10 Alternate: TIMER0_CH2, USART0_RX, USBFS_ID, DCI_D1, EVENTOUT, I2C2_TXFRAME
PA11	103	I/O	5VT	Default: PA11

GD32F427Zx LQFP144				
Pin Name	Pins	Pin Type ⁽¹⁾	I/O Level ⁽²⁾	Functions description
				Alternate: TIMER0_CH3, USART0_CTS, USART5_TX, CAN0_RX, USBFS_DM, EVENTOUT
PA12	104	I/O	5VT	Default: PA12 Alternate: TIMER0_ETI, USART0_RTS, USART5_RX, CAN0_TX, USBFS_DP, EVENTOUT
PA13	105	I/O	5VT	Default: JTMS, SWDIO, PA13 Alternate: EVENTOUT
NC	106	-	-	-
VSS	107	P	-	Default: VSS
VDD	108	P	-	Default: VDD
PA14	109	I/O	5VT	Default: JTCK, SWCLK, PA14 Alternate: EVENTOUT
PA15	110	I/O	5VT	Default: JTDI, PA15 Alternate: TIMER1_CH0, TIMER1_ETI, SPI0_NSS, SPI2_NSS, I2S2_WS, USART0_TX, EVENTOUT
PC10	111	I/O	5VT	Default: PC10 Alternate: SPI2_SCK, I2S2_CK, USART2_TX, UART3_TX, SDIO_D2, DCI_D8, EVENTOUT
PC11	112	I/O	5VT	Default: PC11 Alternate: I2S2_ADD_SD, SPI2_MISO, USART2_RX, UART3_RX, SDIO_D3, DCI_D4, EVENTOUT
PC12	113	I/O	5VT	Default: PC12 Alternate: I2C1_SDA, SPI2_MOSI, I2S2_SD, USART2_CK, UART4_TX, SDIO_CK, DCI_D9, EVENTOUT
PD0	114	I/O	5VT	Default: PD0 Alternate: SPI2_MOSI, I2S2_SD, CAN0_RX, EXMC_D2, EVENTOUT
PD1	115	I/O	5VT	Default: PD1 Alternate: SPI1_NSS, I2S1_WS, CAN0_TX, EXMC_D3, EVENTOUT
PD2	116	I/O	5VT	Default: PD2 Alternate: TIMER2_ETI, UART4_RX, SDIO_CMD, DCI_D11, EVENTOUT
PD3	117	I/O	5VT	Default: PD3 Alternate: SPI1_SCK, I2S1_CK, USART1_CTS, EXMC_CLK, DCI_D5, EVENTOUT
PD4	118	I/O	5VT	Default: PD4 Alternate: USART1_RTS, EXMC_NOE, EVENTOUT
PD5	119	I/O	5VT	Default: PD5 Alternate: USART1_TX, EXMC_NWE, EVENTOUT

GD32F427Zx LQFP144				
Pin Name	Pins	Pin Type ⁽¹⁾	I/O Level ⁽²⁾	Functions description
VSS	120	P	-	Default: VSS
VDD	121	P	-	Default: VDD
PD6	122	I/O	5VT	Default: PD6 Alternate: SPI2_MOSI, I2S2_SD, USART1_RX, EXMC_NWAIT, DCI_D10, EVENTOUT
PD7	123	I/O	5VT	Default: PD7 Alternate: USART1_CK, EXMC_NE0, EXMC_NCE1, EVENTOUT
PG9	124	I/O	5VT	Default: PG9 Alternate: USART5_RX, EXMC_NE1, EXMC_NCE2, DCI_VSYNC, EVENTOUT
PG10	125	I/O	5VT	Default: PG10 Alternate: EXMC_NCE3_0, EXMC_NE2, DCI_D2, EVENTOUT
PG11	126	I/O	5VT	Default: PG11 Alternate: ENET_MII_TX_EN, ENET_RMII_TX_EN, EXMC_NCE3_1, DCI_D3, EVENTOUT
PG12	127	I/O	5VT	Default: PG12 Alternate: USART5_RTS, EXMC_NE3, EVENTOUT
PG13	128	I/O	5VT	Default: PG13 Alternate: USART5_CTS, ENET_MII_TXD0, ENET_RMII_TXD0, EXMC_A24, EVENTOUT
PG14	129	I/O	5VT	Default: PG14 Alternate: USART5_TX, ENET_MII_TXD1, ENET_RMII_TXD1, EXMC_A25, EVENTOUT
VSS	130	P	-	Default: VSS
VDD	131	P	-	Default: VDD
PG15	132	I/O	5VT	Default: PG15 Alternate: USART5_CTS, EXMC_SDNCAS, DCI_D13, EVENTOUT
PB3	133	I/O	5VT	Default: JTDO, PB3 Alternate: TRACESWO, TIMER1_CH1, SPI0_SCK, SPI2_SCK, I2S2_CK, USART0_RX, I2C1_SDA, EVENTOUT
PB4	134	I/O	5VT	Default: NJTRST, PB4 Alternate: TIMER2_CH0, SPI0_MISO, SPI2_MISO, I2S2_ADD_SD, I2C2_SDA, SDIO_D0, EVENTOUT, I2C0_TXFRAME
PB5	135	I/O	5VT	Default: PB5 Alternate: TIMER2_CH1, I2C0_SMBA, SPI0_MOSI, SPI2_MOSI, I2S2_SD, CAN1_RX, USBHS_ULPI_D7, ENET_PPS_OUT, EXMC_SDCKE1, DCI_D10, EVENTOUT

GD32F427Zx LQFP144				
Pin Name	Pins	Pin Type ⁽¹⁾	I/O Level ⁽²⁾	Functions description
PB6	136	I/O	5VT	Default: PB6 Alternate: TIMER3_CH0, I2C0_SCL, USART0_TX, CAN1_TX, EXMC_SDNE1, DCI_D5, EVENTOUT
PB7	137	I/O	5VT	Default: PB7 Alternate: TIMER3_CH1, I2C0_SDA, USART0_RX, EXMC_NL/EXMC_NADV, DCI_VSYNC, EVENTOUT
BOOT0	138	I/O	5VT	Default: BOOT0
PB8	139	I/O	5VT	Default: PB8 Alternate: TIMER1_CH0, TIMER1_ETI, TIMER3_CH2, TIMER9_CH0, I2C0_SCL, CAN0_RX, ENET_MII_TXD3, SDIO_D4, DCI_D6, EVENTOUT
PB9	140	I/O	5VT	Default: PB9 Alternate: TIMER1_CH1, TIMER3_CH3, TIMER10_CH0, I2C0_SDA, SPI1_NSS, I2S1_WS, CAN0_TX, SDIO_D5, DCI_D7, EVENTOUT
PE0	141	I/O	5VT	Default: PE0 Alternate: TIMER3_ETI, EXMC_NBL0, DCI_D2, EVENTOUT
PE1	142	I/O	5VT	Default: PE1 Alternate: TIMER0_CH1_ON, EXMC_NBL1, DCI_D3, EVENTOUT
PDR_ON	143	P	-	Default: PDR_ON
VDD	144	P	-	Default: VDD

Notes:

(1) Type: I = input, O = output, P = power.

(2) I/O Level: 5VT = 5 V tolerant.

2.6.3. GD32F427Vx LQFP100 pin definitions

Table 2-6. GD32F427Vx LQFP100 pin definitions

GD32F427Vx LQFP100				
Pin Name	Pins	Pin Type ⁽¹⁾	I/O Level ⁽²⁾	Functions description
PE2	1	I/O	5VT	Default: PE2 Alternate: ENET_MII_TXD3, EXMC_A23, EVENTOUT
PE3	2	I/O	5VT	Default: PE3 Alternate: EXMC_A19, EVENTOUT
PE4	3	I/O	5VT	Default: PE4 Alternate: EXMC_A20, DCI_D4, EVENTOUT
PE5	4	I/O	5VT	Default: PE5 Alternate: TIMER8_CH0, EXMC_A21, DCI_D6,

GD32F427Vx LQFP100				
Pin Name	Pins	Pin Type ⁽¹⁾	I/O Level ⁽²⁾	Functions description
				EVENTOUT
PE6	5	I/O	5VT	Default: PE6 Alternate: TIMER8_CH1, EXMC_A22, DCI_D7, EVENTOUT
VBAT	6	P	-	Default: VBAT
PC13- TAMPER- RTC	7	I/O	5VT	Default: PC13 Alternate: EVENTOUT Additional: RTC_TAMP0, RTC_OUT, RTC_TS
PC14- OSC32IN	8	I/O	5VT	Default: PC14 Alternate: EVENTOUT Additional: OSC32IN
PC15- OSC32OU T	9	I/O	5VT	Default: PC15 Alternate: EVENTOUT Additional: OSC32OUT
VSS	10	P	-	Default: VSS
VDD	11	P	-	Default: VDD
PH0/OSCI N	12	I/O	5VT	Default: PH0, OSCIN Alternate: EVENTOUT Additional: OSCIN
PH1/OSCO UT	13	I/O	5VT	Default: PH1, OSCOUT Alternate: EVENTOUT Additional: OSCOUT
NRST	14	-	-	Default: NRST
PC0	15	I/O	5VT	Default: PC0 Alternate: USBHS_ULPI_STP, EXMC_SDNWE, EVENTOUT Additional: ADC012_IN10
PC1	16	I/O	5VT	Default: PC1 Alternate: SPI2_MOSI, I2S2_SD, SPI1_MOSI, I2S1_SD, ENET_MDC, EVENTOUT Additional: ADC012_IN11
PC2	17	I/O	5VT	Default: PC2 Alternate: SPI1_MISO, I2S1_ADD_SD, USBHS_ULPI_DIR, ENET_MII_TXD2, EVENTOUT Additional: ADC012_IN12
PC3	18	I/O	5VT	Default: PC3 Alternate: SPI1_MOSI, I2S1_SD, USBHS_ULPI_NXT, ENET_MII_TX_CLK, EVENTOUT Additional: ADC012_IN13
VDD	19	P	-	Default: VDD

GD32F427Vx LQFP100				
Pin Name	Pins	Pin Type ⁽¹⁾	I/O Level ⁽²⁾	Functions description
VSSA	20	P	-	Default: VSSA
VREFP	21	P	-	Default: VREFP
VDDA	22	P	-	Default: VDDA
PA0-WKUP	23	I/O	5VT	Default: PA0 Alternate: TIMER1_CH0, TIMER1_ETI, TIMER4_CH0, TIMER7_ETI, USART1_CTS, UART3_TX, ENET_MII_CRD, EVENTOUT Additional: ADC012_IN0, WKUP
PA1	24	I/O	5VT	Default: PA1 Alternate: TIMER1_CH1, TIMER4_CH1, USART1_RTS, UART3_RX, ENET_MII_RX_CLK, ENET_RMII_REF_CLK, EVENTOUT Additional: ADC012_IN1
PA2	25	I/O	5VT	Default: PA2 Alternate: TIMER1_CH2, TIMER4_CH2, TIMER8_CH0, I2S_CKIN, USART1_TX, ENET_MDIO, EVENTOUT Additional: ADC012_IN2
PA3	26	I/O	5VT	Default: PA3 Alternate: TIMER1_CH3, TIMER4_CH3, TIMER8_CH1, I2S1_MCK, USART1_RX, USBHS_ULPI_D0, ENET_MII_COL, EVENTOUT Additional: ADC012_IN3
VSS	27	P	-	Default: VSS
VDD	28	P	-	Default: VDD
PA4	29	I/O		Default: PA4 Alternate: SPI0_NSS, SPI2_NSS, I2S2_WS, USART1_CK, USBHS_SOF, DCI_HSYNC, EVENTOUT Additional: ADC01_IN4, DAC0_OUT0
PA5	30	I/O		Default: PA5 Alternate: TIMER1_CH0, TIMER1_ETI, TIMER7_CH0_ON, SPI0_SCK, USBHS_ULPI_CK, EVENTOUT Additional: ADC01_IN5, DAC0_OUT1
PA6	31	I/O	5VT	Default: PA6 Alternate: TIMER0_BRKIN, TIMER2_CH0, TIMER7_BRKIN, SPI0_MISO, I2S1_MCK, TIMER12_CH0, SDIO_CMD, DCI_PIXCLK, EVENTOUT Additional: ADC01_IN6
PA7	32	I/O	5VT	Default: PA7 Alternate: TIMER0_CH0_ON, TIMER2_CH1, TIMER7_CH0_ON, SPI0_MOSI, TIMER13_CH0,

GD32F427Vx LQFP100				
Pin Name	Pins	Pin Type ⁽¹⁾	I/O Level ⁽²⁾	Functions description
				ENET_MII_RX_DV, ENET_RMII_CRD_DV, EXMC_SDNWE, EVENTOUT Additional: ADC01_IN7
PC4	33	I/O	5VT	Default: PC4 Alternate: ENET_MII_RXD0, ENET_RMII_RXD0, EVENTOUT Additional: ADC01_IN14
PC5	34	I/O	5VT	Default: PC5 Alternate: USART2_RX, ENET_MII_RXD1, ENET_RMII_RXD1, EVENTOUT Additional: ADC01_IN15
PB0	35	I/O	5VT	Default: PB0 Alternate: TIMER0_CH1_ON, TIMER2_CH2, TIMER7_CH1_ON, SPI2_MOSI, I2S2_SD, USBHS_ULPI_D1, ENET_MII_RXD2, SDIO_D1, EVENTOUT Additional: ADC01_IN8, IREF
PB1	36	I/O	5VT	Default: PB1 Alternate: TIMER0_CH2_ON, TIMER2_CH3, TIMER7_CH2_ON, USBHS_ULPI_D2, ENET_MII_RXD3, SDIO_D2, EVENTOUT Additional: ADC01_IN9
PB2	37	I/O	5VT	Default: PB2, BOOT1 Alternate: TIMER1_CH3, SPI2_MOSI, I2S2_SD, USBHS_ULPI_D4, SDIO_CK, EVENTOUT
PE7	38	I/O	5VT	Default: PE7 Alternate: TIMER0_ETI, EXMC_D4, EVENTOUT
PE8	39	I/O	5VT	Default: PE8 Alternate: TIMER0_CH0_ON, EXMC_D5, EVENTOUT
PE9	40	I/O	5VT	Default: PE9 Alternate: TIMER0_CH0, EXMC_D6, EVENTOUT
PE10	41	I/O	5VT	Default: PE10 Alternate: TIMER0_CH1_ON, EXMC_D7, EVENTOUT
PE11	42	I/O	5VT	Default: PE11 Alternate: TIMER0_CH1, EXMC_D8, EVENTOUT
PE12	43	I/O	5VT	Default: PE12 Alternate: TIMER0_CH2_ON, EXMC_D9, EVENTOUT
PE13	44	I/O	5VT	Default: PE13 Alternate: TIMER0_CH2, EXMC_D10, EVENTOUT
PE14	45	I/O	5VT	Default: PE14

GD32F427Vx LQFP100				
Pin Name	Pins	Pin Type ⁽¹⁾	I/O Level ⁽²⁾	Functions description
				Alternate: TIMER0_CH3, EXMC_D11, EVENTOUT
PE15	46	I/O	5VT	Default: PE15 Alternate: TIMER0_BRKIN, EXMC_D12, EVENTOUT
PB10	47	I/O	5VT	Default: PB10 Alternate: TIMER1_CH2, I2C1_SCL, SPI1_SCK, I2S1_CK, I2S2_MCK, USART2_TX, USBHS_ULPI_D3, ENET_MII_RX_ER, SDIO_D7, EVENTOUT
PB11	48	I/O	5VT	Default: PB11 Alternate: TIMER1_CH3, I2C1_SDA, I2S_CKIN, USART2_RX, USBHS_ULPI_D4, ENET_MII_TX_EN, ENET_RMII_TX_EN, EVENTOUT
NC	49	-	-	-
VDD	50	P	-	Default: VDD
PB12	51	I/O	5VT	Default: PB12 Alternate: TIMER0_BRKIN, I2C1_SMBA, SPI1_NSS, I2S1_WS, USART2_CK, CAN1_RX, USBHS_ULPI_D5, ENET_MII_TXD0, ENET_RMII_TXD0, USBHS_ID, EVENTOUT
PB13	52	I/O	5VT	Default: PB13 Alternate: TIMER0_CH0_ON, SPI1_SCK, I2S1_CK, USART2_CTS, CAN1_TX, USBHS_ULPI_D6, ENET_MII_TXD1, ENET_RMII_TXD1, EVENTOUT, I2C1_TXFRAME Additional: USBHS_VBUS
PB14	53	I/O	5VT	Default: PB14 Alternate: TIMER0_CH1_ON, TIMER7_CH1_ON, SPI1_MISO, I2S1_ADD_SD, USART2_RTS, TIMER11_CH0, USBHS_DM, EVENTOUT
PB15	54	I/O	5VT	Default: PB15 Alternate: RTC_REFIN, TIMER0_CH2_ON, TIMER7_CH2_ON, SPI1_MOSI, I2S1_SD, TIMER11_CH1, USBHS_DP, EVENTOUT
PD8	55	I/O	5VT	Default: PD8 Alternate: USART2_TX, EXMC_D13, EVENTOUT
PD9	56	I/O	5VT	Default: PD9 Alternate: USART2_RX, EXMC_D14, EVENTOUT
PD10	57	I/O	5VT	Default: PD10 Alternate: USART2_CK, EXMC_D15, EVENTOUT
PD11	58	I/O	5VT	Default: PD11 Alternate: USART2_CTS, EXMC_A16/EXMC_CLE,

GD32F427Vx LQFP100				
Pin Name	Pins	Pin Type ⁽¹⁾	I/O Level ⁽²⁾	Functions description
				EVENTOUT
PD12	59	I/O	5VT	Default: PD12 Alternate: TIMER3_CH0, USART2_RTS, EXMC_A17/EXMC_ALE, EVENTOUT
PD13	60	I/O	5VT	Default: PD13 Alternate: TIMER3_CH1, EXMC_A18, EVENTOUT
PD14	61	I/O	5VT	Default: PD14 Alternate: TIMER3_CH2, EXMC_D0, EVENTOUT
PD15	62	I/O	5VT	Default: PD15 Alternate: TIMER3_CH3, EXMC_D1, EVENTOUT, CTC_SYNC
PC6	63	I/O	5VT	Default: PC6 Alternate: TIMER2_CH0, TIMER7_CH0, I2S1_MCK, USART5_TX, SDIO_D6, DCI_D0, EVENTOUT
PC7	64	I/O	5VT	Default: PC7 Alternate: TIMER2_CH1, TIMER7_CH1, SPI1_SCK, I2S1_CK, I2S2_MCK, USART5_RX, SDIO_D7, DCI_D1, EVENTOUT
PC8	65	I/O	5VT	Default: PC8 Alternate: TIMER2_CH2, TIMER7_CH2, USART5_CK, SDIO_D0, DCI_D2, EVENTOUT
PC9	66	I/O	5VT	Default: PC9 Alternate: CK_OUT1, TIMER2_CH3, TIMER7_CH3, I2C2_SDA, I2S_CKIN, SDIO_D1, DCI_D3, EVENTOUT
PA8	67	I/O	5VT	Default: PA8 Alternate: CK_OUT0, TIMER0_CH0, I2C2_SCL, USART0_CK, USBFS_SOF, SDIO_D1, EVENTOUT, CTC_SYNC
PA9	68	I/O	5VT	Default: PA9 Alternate: TIMER0_CH1, I2C2_SMBA, SPI1_SCK, I2S1_CK, USART0_TX, SDIO_D2, DCI_D0, EVENTOUT Additional: USBFS_VBUS
PA10	69	I/O	5VT	Default: PA10 Alternate: TIMER0_CH2, USART0_RX, USBFS_ID, DCI_D1, EVENTOUT, I2C2_TXFRAME
PA11	70	I/O	5VT	Default: PA11 Alternate: TIMER0_CH3, USART0_CTS, USART5_TX, CAN0_RX, USBFS_DM, EVENTOUT
PA12	71	I/O	5VT	Default: PA12 Alternate: TIMER0_ETI, USART0_RTS, USART5_RX,

GD32F427Vx LQFP100				
Pin Name	Pins	Pin Type ⁽¹⁾	I/O Level ⁽²⁾	Functions description
				CAN0_TX, USBFS_DP, EVENTOUT
PA13	72	I/O	5VT	Default: JTMS, SWDIO, PA13 Alternate: EVENTOUT
NC	73	-	-	-
VSS	74	P	-	Default: VSS
VDD	75	P	-	Default: VDD
PA14	76	I/O	5VT	Default: JTCK, SWCLK, PA14 Alternate: EVENTOUT
PA15	77	I/O	5VT	Default: JTDI, PA15 Alternate: TIMER1_CH0, TIMER1_ETI, SPI0_NSS, SPI2_NSS, I2S2_WS, USART0_TX, EVENTOUT
PC10	78	I/O	5VT	Default: PC10 Alternate: SPI2_SCK, I2S2_CK, USART2_TX, UART3_TX, SDIO_D2, DCI_D8, EVENTOUT
PC11	79	I/O	5VT	Default: PC11 Alternate: I2S2_ADD_SD, SPI2_MISO, USART2_RX, UART3_RX, SDIO_D3, DCI_D4, EVENTOUT
PC12	80	I/O	5VT	Default: PC12 Alternate: I2C1_SDA, SPI2_MOSI, I2S2_SD, USART2_CK, UART4_TX, SDIO_CK, DCI_D9, EVENTOUT
PD0	81	I/O	5VT	Default: PD0 Alternate: SPI2_MOSI, I2S2_SD, CAN0_RX, EXMC_D2, EVENTOUT
PD1	82	I/O	5VT	Default: PD1 Alternate: SPI1_NSS, I2S1_WS, CAN0_TX, EXMC_D3, EVENTOUT
PD2	83	I/O	5VT	Default: PD2 Alternate: TIMER2_ETI, UART4_RX, SDIO_CMD, DCI_D11, EVENTOUT
PD3	84	I/O	5VT	Default: PD3 Alternate: SPI1_SCK, I2S1_CK, USART1_CTS, EXMC_CLK, DCI_D5, EVENTOUT
PD4	85	I/O	5VT	Default: PD4 Alternate: USART1_RTS, EXMC_NOE, EVENTOUT
PD5	86	I/O	5VT	Default: PD5 Alternate: USART1_TX, EXMC_NWE, EVENTOUT
PD6	87	I/O	5VT	Default: PD6 Alternate: SPI2_MOSI, I2S2_SD, USART1_RX, EXMC_NWAIT, DCI_D10, EVENTOUT
PD7	88	I/O	5VT	Default: PD7

GD32F427Vx LQFP100				
Pin Name	Pins	Pin Type ⁽¹⁾	I/O Level ⁽²⁾	Functions description
				Alternate: USART1_CK, EXMC_NE0, EXMC_NCE1, EVENTOUT
PB3	89	I/O	5VT	Default: JTDO, PB3 Alternate: TRACESWO, TIMER1_CH1, SPI0_SCK, SPI2_SCK, I2S2_CK, USART0_RX, I2C1_SDA, EVENTOUT
PB4	90	I/O	5VT	Default: NJTRST, PB4 Alternate: TIMER2_CH0, SPI0_MISO, SPI2_MISO, I2S2_ADD_SD, I2C2_SDA, SDIO_D0, EVENTOUT, I2C0_TXFRAME
PB5	91	I/O	5VT	Default: PB5 Alternate: TIMER2_CH1, I2C0_SMBA, SPI0_MOSI, SPI2_MOSI, I2S2_SD, CAN1_RX, USBHS_ULPI_D7, ENET_PPS_OUT, DCI_D10, EVENTOUT
PB6	92	I/O	5VT	Default: PB6 Alternate: TIMER3_CH0, I2C0_SCL, USART0_TX, CAN1_TX, DCI_D5, EVENTOUT
PB7	93	I/O	5VT	Default: PB7 Alternate: TIMER3_CH1, I2C0_SDA, USART0_RX, EXMC_NL/EXMC_NADV, DCI_VSYNC, EVENTOUT
BOOT0	94	I/O	5VT	Default: BOOT0
PB8	95	I/O	5VT	Default: PB8 Alternate: TIMER1_CH0, TIMER1_ETI, TIMER3_CH2, TIMER9_CH0, I2C0_SCL, CAN0_RX, ENET_MII_TXD3, SDIO_D4, DCI_D6, EVENTOUT
PB9	96	I/O	5VT	Default: PB9 Alternate: TIMER1_CH1, TIMER3_CH3, TIMER10_CH0, I2C0_SDA, SPI1_NSS, I2S1_WS, CAN0_TX, SDIO_D5, DCI_D7, EVENTOUT
PE0	97	I/O	5VT	Default: PE0 Alternate: TIMER3_ETI, EXMC_NBL0, DCI_D2, EVENTOUT
PE1	98	I/O	5VT	Default: PE1 Alternate: TIMER0_CH1_ON, EXMC_NBL1, DCI_D3, EVENTOUT
VSS	99	P	-	Default: VSS
VDD	100	P	-	Default: VDD

Notes:

(1) Type: I = input, O = output, P = power.

(2) I/O Level: 5VT = 5 V tolerant.

2.6.4. GD32F427Vx BGA100 pin definitions

Table 2-7. GD32F427Vx BGA100 pin definitions

GD32F427Vx BGA100				
Pin Name	Pins	Pin Type ⁽¹⁾	I/O Level ⁽²⁾	Functions description
PE2	B2	I/O	5VT	Default: PE2 Alternate: ENET_MII_TXD3, EXMC_A23, EVENTOUT
PE3	A1	I/O	5VT	Default: PE3 Alternate: EXMC_A19, EVENTOUT
PE4	B1	I/O	5VT	Default: PE4 Alternate: EXMC_A20, DCI_D4, EVENTOUT
PE5	C2	I/O	5VT	Default: PE5 Alternate: TIMER8_CH0, EXMC_A21, DCI_D6, EVENTOUT
PE6	D2	I/O	5VT	Default: PE6 Alternate: TIMER8_CH1, EXMC_A22, DCI_D7, EVENTOUT
VBAT	E2	P	-	Default: VBAT
PC13- TAMPER- RTC	C1	I/O	5VT	Default: PC13 Alternate: EVENTOUT Additional: RTC_TAMP0, RTC_OUT, RTC_TS
PC14- OSC32IN	D1	I/O	5VT	Default: PC14 Alternate: EVENTOUT Additional: OSC32IN
PC15- OSC32O UT	E1	I/O	5VT	Default: PC15 Alternate: EVENTOUT Additional: OSC32OUT
VSS	F2	P	-	Default: VSS
VDD	G2	P	-	Default: VDD
PH0/OSC IN	F1	I/O	5VT	Default: PH0, OSCIN Alternate: EVENTOUT Additional: OSCIN
PH1/OSC OUT	G1	I/O	5VT	Default: PH1, OSCOUT Alternate: EVENTOUT Additional: OSCOUT
NRST	H2	-	-	Default: NRST
PC0	H1	I/O	5VT	Default: PC0 Alternate: USBHS_ULPI_STP, EVENTOUT Additional: ADC012_IN10
PC1	J2	I/O	5VT	Default: PC1 Alternate: SPI2_MOSI, I2S2_SD, SPI1_MOSI, I2S1_SD, ENET_MDC, EVENTOUT Additional: ADC012_IN11
PC2	J3	I/O	5VT	Default: PC2

GD32F427Vx BGA100				
Pin Name	Pins	Pin Type ⁽¹⁾	I/O Level ⁽²⁾	Functions description
				Alternate: SPI1_MISO, I2S1_ADD_SD, USBHS_ULPI_DIR, ENET_MII_TXD2, EVENTOUT Additional: ADC012_IN12
PC3	K2	I/O	5VT	Default: PC3 Alternate: SPI1_MOSI, I2S1_SD, USBHS_ULPI_NXT, ENET_MII_TX_CLK, EVENTOUT Additional: ADC012_IN13
VSSA	J1	P	-	Default: VSSA
VREFN	K1	P	-	Default: VREFN
VREFP	L1	P	-	Default: VREFP
VDDA	M1	P	-	Default: VDDA
PA0-WKUP	L2	I/O	5VT	Default: PA0 Alternate: TIMER1_CH0, TIMER1_ETI, TIMER4_CH0, TIMER7_ETI, USART1_CTS, UART3_TX, ENET_MII_CRS, EVENTOUT Additional: ADC012_IN0, WKUP
PA1	M2	I/O	5VT	Default: PA1 Alternate: TIMER1_CH1, TIMER4_CH1, USART1_RTS, UART3_RX, ENET_MII_RX_CLK, ENET_RMII_REF_CLK, EVENTOUT Additional: ADC012_IN1
PA2	K3	I/O	5VT	Default: PA2 Alternate: TIMER1_CH2, TIMER4_CH2, TIMER8_CH0, I2S_CKIN, USART1_TX, ENET_MDIO, EVENTOUT Additional: ADC012_IN2
PA3	L3	I/O	5VT	Default: PA3 Alternate: TIMER1_CH3, TIMER4_CH3, TIMER8_CH1, I2S1_MCK, USART1_RX, USBHS_ULPI_D0, ENET_MII_COL, EVENTOUT Additional: ADC012_IN3
NC	E3	-	-	-
PA4	M3	I/O		Default: PA4 Alternate: SPI0_NSS, SPI2_NSS, I2S2_WS, USART1_CK, USBHS_SOF, DCI_HSYNC, EVENTOUT Additional: ADC01_IN4, DAC0_OUT0
PA5	K4	I/O		Default: PA5 Alternate: TIMER1_CH0, TIMER1_ETI, TIMER7_CH0_ON, SPI0_SCK, USBHS_ULPI_CK, EVENTOUT Additional: ADC01_IN5, DAC0_OUT1
PA6	L4	I/O	5VT	Default: PA6

GD32F427Vx BGA100				
Pin Name	Pins	Pin Type ⁽¹⁾	I/O Level ⁽²⁾	Functions description
				Alternate: TIMER0_BRKIN, TIMER2_CH0, TIMER7_BRKIN, SPI0_MISO, I2S1_MCK, TIMER12_CH0, SDIO_CMD, DCI_PIXCLK, EVENTOUT Additional: ADC01_IN6
PA7	M4	I/O	5VT	Default: PA7 Alternate: TIMER0_CH0_ON, TIMER2_CH1, TIMER7_CH0_ON, SPI0_MOSI, TIMER13_CH0, ENET_MII_RX_DV, ENET_RMII_CRS_DV, EVENTOUT Additional: ADC01_IN7
PC4	K5	I/O	5VT	Default: PC4 Alternate: ENET_MII_RXD0, ENET_RMII_RXD0, EVENTOUT Additional: ADC01_IN14
PC5	L5	I/O	5VT	Default: PC5 Alternate: USART2_RX, ENET_MII_RXD1, ENET_RMII_RXD1, EVENTOUT Additional: ADC01_IN15
PB0	M5	I/O	5VT	Default: PB0 Alternate: TIMER0_CH1_ON, TIMER2_CH2, TIMER7_CH1_ON, SPI2_MOSI, I2S2_SD, USBHS_ULPI_D1, ENET_MII_RXD2, SDIO_D1, EVENTOUT Additional: ADC01_IN8, IREF
PB1	M6	I/O	5VT	Default: PB1 Alternate: TIMER0_CH2_ON, TIMER2_CH3, TIMER7_CH2_ON, USBHS_ULPI_D2, ENET_MII_RXD3, SDIO_D2, EVENTOUT Additional: ADC01_IN9
PB2	L6	I/O	5VT	Default: PB2, BOOT1 Alternate: TIMER1_CH3, SPI2_MOSI, I2S2_SD, USBHS_ULPI_D4, SDIO_CK, EVENTOUT
PE7	M7	I/O	5VT	Default: PE7 Alternate: TIMER0_ETI, EXMC_D4, EVENTOUT
PE8	L7	I/O	5VT	Default: PE8 Alternate: TIMER0_CH0_ON, EXMC_D5, EVENTOUT
PE9	M8	I/O	5VT	Default: PE9 Alternate: TIMER0_CH0, EXMC_D6, EVENTOUT
PE10	L8	I/O	5VT	Default: PE10 Alternate: TIMER0_CH1_ON, EXMC_D7, EVENTOUT
PE11	M9	I/O	5VT	Default: PE11 Alternate: TIMER0_CH1, EVENTOUT

GD32F427Vx BGA100				
Pin Name	Pins	Pin Type ⁽¹⁾	I/O Level ⁽²⁾	Functions description
PE12	L9	I/O	5VT	Default: PE12 Alternate: TIMER0_CH2_ON, EVENTOUT
PE13	M10	I/O	5VT	Default: PE13 Alternate: TIMER0_CH2, EVENTOUT
PE14	M11	I/O	5VT	Default: PE14 Alternate: TIMER0_CH3, EVENTOUT
PE15	M12	I/O	5VT	Default: PE15 Alternate: TIMER0_BRKIN, EVENTOUT
PB10	L10	I/O	5VT	Default: PB10 Alternate: TIMER1_CH2, I2C1_SCL, SPI1_SCK, I2S1_CK, I2S2_MCK, USART2_TX, USBHS_ULPI_D3, ENET_MII_RX_ER, SDIO_D7, EVENTOUT
PB11	K9	I/O	5VT	Default: PB11 Alternate: TIMER1_CH3, I2C1_SDA, I2S_CKIN, USART2_RX, USBHS_ULPI_D4, ENET_MII_TX_EN, ENET_RMII_TX_EN, EVENTOUT
NC	L11	-	-	-
VSS	F12	P	-	Default: VSS
VDD	G12	P	-	Default: VDD
PB12	L12	I/O	5VT	Default: PB12 Alternate: TIMER0_BRKIN, I2C1_SMBA, SPI1_NSS, I2S1_WS, USART2_CK, CAN1_RX, USBHS_ULPI_D5, ENET_MII_TXD0, ENET_RMII_TXD0, USBHS_ID, EVENTOUT
PB13	K12	I/O	5VT	Default: PB13 Alternate: TIMER0_CH0_ON, SPI1_SCK, I2S1_CK, USART2_CTS, CAN1_TX, USBHS_ULPI_D6, ENET_MII_TXD1, ENET_RMII_TXD1, EVENTOUT, I2C1_TXFRAME Additional: USBHS_VBUS
PB14	K11	I/O	5VT	Default: PB14 Alternate: TIMER0_CH1_ON, TIMER7_CH1_ON, SPI1_MISO, I2S1_ADD_SD, USART2_RTS, TIMER11_CH0, USBHS_DM, EVENTOUT
PB15	K10	I/O	5VT	Default: PB15 Alternate: RTC_REFIN, TIMER0_CH2_ON, TIMER7_CH2_ON, SPI1_MOSI, I2S1_SD, TIMER11_CH1, USBHS_DP, EVENTOUT
PD9	K8	I/O	5VT	Default: PD9 Alternate: USART2_RX, EVENTOUT

GD32F427Vx BGA100				
Pin Name	Pins	Pin Type ⁽¹⁾	I/O Level ⁽²⁾	Functions description
PD10	J12	I/O	5VT	Default: PD10 Alternate: USART2_CK, EVENTOUT
PD11	J11	I/O	5VT	Default: PD11 Alternate: USART2_CTS, EXMC_A16/EXMC_CLE, EVENTOUT
PD12	J10	I/O	5VT	Default: PD12 Alternate: TIMER3_CH0, USART2_RTS, EXMC_A17/EXMC_ALE, EVENTOUT
PD13	H12	I/O	5VT	Default: PD13 Alternate: TIMER3_CH1, EXMC_A18, EVENTOUT
PD14	H11	I/O	5VT	Default: PD14 Alternate: TIMER3_CH2, EXMC_D0, EVENTOUT
PD15	H10	I/O	5VT	Default: PD15 Alternate: TIMER3_CH3, EXMC_D1, EVENTOUT, CTC_SYNC
PC6	E12	I/O	5VT	Default: PC6 Alternate: TIMER2_CH0, TIMER7_CH0, I2S1_MCK, USART5_TX, SDIO_D6, DCI_D0, EVENTOUT
PC7	E11	I/O	5VT	Default: PC7 Alternate: TIMER2_CH1, TIMER7_CH1, SPI1_SCK, I2S1_CK, I2S2_MCK, USART5_RX, SDIO_D7, DCI_D1, EVENTOUT
PC8	E10	I/O	5VT	Default: PC8 Alternate: TIMER2_CH2, TIMER7_CH2, USART5_CK, SDIO_D0, DCI_D2, EVENTOUT
PC9	D12	I/O	5VT	Default: PC9 Alternate: CK_OUT1, TIMER2_CH3, TIMER7_CH3, I2C2_SDA, I2S_CKIN, SDIO_D1, DCI_D3, EVENTOUT
PA8	D11	I/O	5VT	Default: PA8 Alternate: CK_OUT0, TIMER0_CH0, I2C2_SCL, USART0_CK, USBFS_SOF, SDIO_D1, EVENTOUT, CTC_SYNC
PA9	D10	I/O	5VT	Default: PA9 Alternate: TIMER0_CH1, I2C2_SMBA, SPI1_SCK, I2S1_CK, USART0_TX, SDIO_D2, DCI_D0, EVENTOUT Additional: USBFS_VBUS
PA10	C12	I/O	5VT	Default: PA10 Alternate: TIMER0_CH2, USART0_RX, USBFS_ID, DCI_D1, EVENTOUT, I2C2_TXFRAME
PA11	B12	I/O	5VT	Default: PA11

GD32F427Vx BGA100				
Pin Name	Pins	Pin Type ⁽¹⁾	I/O Level ⁽²⁾	Functions description
				Alternate: TIMER0_CH3, USART0_CTS, USART5_TX, CAN0_RX, USBFS_DM, EVENTOUT
PA12	A12	I/O	5VT	Default: PA12 Alternate: TIMER0_ETI, USART0_RTS, USART5_RX, CAN0_TX, USBFS_DP, EVENTOUT
PA13	A11	I/O	5VT	Default: JTMS, SWDIO, PA13 Alternate: EVENTOUT
NC	C11	-	-	-
VSS	F11	P	-	Default: VSS
VDD	G11	P	-	Default: VDD
PA14	A10	I/O	5VT	Default: JTCK, SWCLK, PA14 Alternate: EVENTOUT
PA15	A9	I/O	5VT	Default: JTDI, PA15 Alternate: TIMER1_CH0, TIMER1_ETI, SPI0_NSS, SPI2_NSS, I2S2_WS, USART0_TX, EVENTOUT
PC10	B11	I/O	5VT	Default: PC10 Alternate: SPI2_SCK, I2S2_CK, USART2_TX, UART3_TX, SDIO_D2, DCI_D8, EVENTOUT
PC11	C10	I/O	5VT	Default: PC11 Alternate: I2S2_ADD_SD, SPI2_MISO, USART2_RX, UART3_RX, SDIO_D3, DCI_D4, EVENTOUT
PC12	B10	I/O	5VT	Default: PC12 Alternate: I2C1_SDA, SPI2_MOSI, I2S2_SD, USART2_CK, UART4_TX, SDIO_CK, DCI_D9, EVENTOUT
PD0	C9	I/O	5VT	Default: PD0 Alternate: SPI2_MOSI, I2S2_SD, CAN0_RX, EXMC_D2, EVENTOUT
PD1	B9	I/O	5VT	Default: PD1 Alternate: SPI1_NSS, I2S1_WS, CAN0_TX, EXMC_D3, EVENTOUT
PD2	C8	I/O	5VT	Default: PD2 Alternate: TIMER2_ETI, UART4_RX, SDIO_CMD, DCI_D11, EVENTOUT
PD3	B8	I/O	5VT	Default: PD3 Alternate: SPI1_SCK, I2S1_CK, USART1_CTS, EXMC_CLK, DCI_D5, EVENTOUT
PD4	B7	I/O	5VT	Default: PD4 Alternate: USART1_RTS, EXMC_NOE, EVENTOUT
PD5	A6	I/O	5VT	Default: PD5 Alternate: USART1_TX, EXMC_NWE, EVENTOUT

GD32F427Vx BGA100				
Pin Name	Pins	Pin Type ⁽¹⁾	I/O Level ⁽²⁾	Functions description
PD6	B6	I/O	5VT	Default: PD6 Alternate: SPI2_MOSI, I2S2_SD, USART1_RX, EXMC_NWAIT, DCI_D10, EVENTOUT
PD7	A5	I/O	5VT	Default: PD7 Alternate: USART1_CK, EXMC_NE0, EXMC_NCE1, EVENTOUT
PB3	A8	I/O	5VT	Default: JTDO, PB3 Alternate: TRACESWO, TIMER1_CH1, SPI0_SCK, SPI2_SCK, I2S2_CK, USART0_RX, I2C1_SDA, EVENTOUT
PB4	A7	I/O	5VT	Default: NJTRST, PB4 Alternate: TIMER2_CH0, SPI0_MISO, SPI2_MISO, I2S2_ADD_SD, I2C2_SDA, SDIO_D0, EVENTOUT, I2C0_TXFRAME
PB5	C5	I/O	5VT	Default: PB5 Alternate: TIMER2_CH1, I2C0_SMBA, SPI0_MOSI, SPI2_MOSI, I2S2_SD, CAN1_RX, USBHS_ULPI_D7, ENET_PPS_OUT, DCI_D10, EVENTOUT
PB6	B5	I/O	5VT	Default: PB6 Alternate: TIMER3_CH0, I2C0_SCL, USART0_TX, CAN1_TX, DCI_D5, EVENTOUT
PB7	B4	I/O	5VT	Default: PB7 Alternate: TIMER3_CH1, I2C0_SDA, USART0_RX, EXMC_NL/EXMC_NADV, DCI_VSYNC, EVENTOUT
BOOT0	A4	I/O	5VT	Default: BOOT0
PB8	A3	I/O	5VT	Default: PB8 Alternate: TIMER1_CH0, TIMER1_ETI, TIMER3_CH2, TIMER9_CH0, I2C0_SCL, CAN0_RX, ENET_MII_TXD3, SDIO_D4, DCI_D6, EVENTOUT
PB9	B3	I/O	5VT	Default: PB9 Alternate: TIMER1_CH1, TIMER3_CH3, TIMER10_CH0, I2C0_SDA, SPI1_NSS, I2S1_WS, CAN0_TX, SDIO_D5, DCI_D7, EVENTOUT
PE0	C3	I/O	5VT	Default: PE0 Alternate: TIMER3_ETI, EXMC_NBL0, DCI_D2, EVENTOUT
PE1	A2	I/O	5VT	Default: PE1 Alternate: TIMER0_CH1_ON, EXMC_NBL1, DCI_D3, EVENTOUT
VSS	D3	P	-	Default: VSS
PDR_ON	H3	P	-	Default: PDR_ON
VDD	C4	P	-	Default: VDD

Notes:

(1) Type: I = input, O = output, P = power.

(2) I/O Level: 5VT = 5 V tolerant.

2.6.5. GD32F427Rx LQFP64 pin definitions
Table 2-8. GD32F427Rx LQFP64 pin definitions

GD32F427Rx LQFP64				
Pin Name	Pins	Pin Type ⁽¹⁾	I/O Level ⁽²⁾	Functions description
VBAT	1	P	-	Default: VBAT
PC13-TAMPER-RTC	2	I/O	5VT	Default: PC13 Alternate: EVENTOUT Additional: RTC_TAMP0, RTC_OUT, RTC_TS
PC14-OSC32IN	3	I/O	5VT	Default: PC14 Alternate: EVENTOUT Additional: OSC32IN
PC15-OSC32OUT	4	I/O	5VT	Default: PC15 Alternate: EVENTOUT Additional: OSC32OUT
PH0/OSCIN	5	I/O	5VT	Default: PH0, OSCIN Alternate: EVENTOUT Additional: OSCIN
PH1/OSCOUT	6	I/O	5VT	Default: PH1, OSCOUT Alternate: EVENTOUT Additional: OSCOUT
NRST	7	-	-	Default: NRST
PC0	8	I/O	5VT	Default: PC0 Alternate: USBHS_ULPI_STP, EVENTOUT Additional: ADC012_IN10
PC1	9	I/O	5VT	Default: PC1 Alternate: SPI2_MOSI, I2S2_SD, SPI1_MOSI, I2S1_SD, ENET_MDC, EVENTOUT Additional: ADC012_IN11
PC2	10	I/O	5VT	Default: PC2 Alternate: SPI1_MISO, I2S1_ADD_SD, USBHS_ULPI_DIR, ENET_MII_TXD2, EVENTOUT Additional: ADC012_IN12
PC3	11	I/O	5VT	Default: PC3 Alternate: SPI1_MOSI, I2S1_SD, USBHS_ULPI_NXT, ENET_MII_TX_CLK, EVENTOUT Additional: ADC012_IN13
VSSA	12	P	-	Default: VSSA

GD32F427Rx LQFP64				
Pin Name	Pins	Pin Type ⁽¹⁾	I/O Level ⁽²⁾	Functions description
VDDA	13	P	-	Default: VDDA
PA0-WKUP	14	I/O	5VT	Default: PA0 Alternate: TIMER1_CH0, TIMER1_ETI, TIMER4_CH0, TIMER7_ETI, USART1_CTS, UART3_TX, ENET_MII_CRCS, EVENTOUT Additional: ADC012_IN0, WKUP
PA1	15	I/O	5VT	Default: PA1 Alternate: TIMER1_CH1, TIMER4_CH1, USART1_RTS, UART3_RX, ENET_MII_RX_CLK, ENET_RMII_REF_CLK, EVENTOUT Additional: ADC012_IN1
PA2	16	I/O	5VT	Default: PA2 Alternate: TIMER1_CH2, TIMER4_CH2, TIMER8_CH0, I2S_CKIN, USART1_TX, ENET_MDIO, EVENTOUT Additional: ADC012_IN2
PA3	17	I/O	5VT	Default: PA3 Alternate: TIMER1_CH3, TIMER4_CH3, TIMER8_CH1, I2S1_MCK, USART1_RX, USBHS_ULPI_D0, ENET_MII_COL, EVENTOUT Additional: ADC012_IN3
VSS	18	P	-	Default: VSS
VDD	19	P	-	Default: VDD
PA4	20	I/O		Default: PA4 Alternate: SPI0_NSS, SPI2_NSS, I2S2_WS, USART1_CK, USBHS_SOF, DCI_HSYNC, EVENTOUT Additional: ADC01_IN4, DAC0_OUT0
PA5	21	I/O		Default: PA5 Alternate: TIMER1_CH0, TIMER1_ETI, TIMER7_CH0_ON, SPI0_SCK, USBHS_ULPI_CK, EVENTOUT Additional: ADC01_IN5, DAC0_OUT1
PA6	22	I/O	5VT	Default: PA6 Alternate: TIMER0_BRKIN, TIMER2_CH0, TIMER7_BRKIN, SPI0_MISO, I2S1_MCK, TIMER12_CH0, SDIO_CMD, DCI_PIXCLK, EVENTOUT Additional: ADC01_IN6
PA7	23	I/O	5VT	Default: PA7 Alternate: TIMER0_CH0_ON, TIMER2_CH1, TIMER7_CH0_ON, SPI0_MOSI, TIMER13_CH0, ENET_MII_RX_DV, ENET_RMII_CRCS_DV, EVENTOUT Additional: ADC01_IN7

GD32F427Rx LQFP64				
Pin Name	Pins	Pin Type ⁽¹⁾	I/O Level ⁽²⁾	Functions description
PC4	24	I/O	5VT	Default: PC4 Alternate: ENET_MII_RXD0, ENET_RMII_RXD0, EVENTOUT Additional: ADC01_IN14
PC5	25	I/O	5VT	Default: PC5 Alternate: USART2_RX, ENET_MII_RXD1, ENET_RMII_RXD1, EVENTOUT Additional: ADC01_IN15
PB0	26	I/O	5VT	Default: PB0 Alternate: TIMER0_CH1_ON, TIMER2_CH2, TIMER7_CH1_ON, SPI2_MOSI, I2S2_SD, USBHS_ULPI_D1, ENET_MII_RXD2, SDIO_D1, EVENTOUT Additional: ADC01_IN8, IREF
PB1	27	I/O	5VT	Default: PB1 Alternate: TIMER0_CH2_ON, TIMER2_CH3, TIMER7_CH2_ON, USBHS_ULPI_D2, ENET_MII_RXD3, SDIO_D2, EVENTOUT Additional: ADC01_IN9
PB2	28	I/O	5VT	Default: PB2, BOOT1 Alternate: TIMER1_CH3, SPI2_MOSI, I2S2_SD, USBHS_ULPI_D4, SDIO_CK, EVENTOUT
PB10	29	I/O	5VT	Default: PB10 Alternate: TIMER1_CH2, I2C1_SCL, SPI1_SCK, I2S1_CK, I2S2_MCK, USART2_TX, USBHS_ULPI_D3, ENET_MII_RX_ER, SDIO_D7, EVENTOUT
PB11	30	I/O	5VT	Default: PB11 Alternate: TIMER1_CH3, I2C1_SDA, I2S_CKIN, USART2_RX, USBHS_ULPI_D4, ENET_MII_TX_EN, ENET_RMII_TX_EN, EVENTOUT
NC	31	-	-	-
VDD	32	P	-	Default: VDD
PB12	33	I/O	5VT	Default: PB12 Alternate: TIMER0_BRKIN, I2C1_SMBA, SPI1_NSS, I2S1_WS, USART2_CK, CAN1_RX, USBHS_ULPI_D5, ENET_MII_TXD0, ENET_RMII_TXD0, USBHS_ID, EVENTOUT
PB13	34	I/O	5VT	Default: PB13 Alternate: TIMER0_CH0_ON, SPI1_SCK, I2S1_CK, USART2_CTS, CAN1_TX, USBHS_ULPI_D6,

GD32F427Rx LQFP64				
Pin Name	Pins	Pin Type ⁽¹⁾	I/O Level ⁽²⁾	Functions description
				ENET_MII_TXD1, ENET_RMII_TXD1, EVENTOUT, I2C1_TXFRAME Additional: USBHS_VBUS
PB14	35	I/O	5VT	Default: PB14 Alternate: TIMER0_CH1_ON, TIMER7_CH1_ON, SPI1_MISO, I2S1_ADD_SD, USART2_RTS, TIMER11_CH0, USBHS_DM, EVENTOUT
PB15	36	I/O	5VT	Default: PB15 Alternate: RTC_REFIN, TIMER0_CH2_ON, TIMER7_CH2_ON, SPI1_MOSI, I2S1_SD, TIMER11_CH1, USBHS_DP, EVENTOUT
PC6	37	I/O	5VT	Default: PC6 Alternate: TIMER2_CH0, TIMER7_CH0, I2S1_MCK, USART5_TX, SDIO_D6, DCI_D0, EVENTOUT
PC7	38	I/O	5VT	Default: PC7 Alternate: TIMER2_CH1, TIMER7_CH1, SPI1_SCK, I2S1_CK, I2S2_MCK, USART5_RX, SDIO_D7, DCI_D1, EVENTOUT
PC8	39	I/O	5VT	Default: PC8 Alternate: TIMER2_CH2, TIMER7_CH2, USART5_CK, SDIO_D0, DCI_D2, EVENTOUT
PC9	40	I/O	5VT	Default: PC9 Alternate: CK_OUT1, TIMER2_CH3, TIMER7_CH3, I2C2_SDA, I2S_CKIN, SDIO_D1, DCI_D3, EVENTOUT
PA8	41	I/O	5VT	Default: PA8 Alternate: CK_OUT0, TIMER0_CH0, I2C2_SCL, USART0_CK, USBFS_SOF, SDIO_D1, EVENTOUT, CTC_SYNC
PA9	42	I/O	5VT	Default: PA9 Alternate: TIMER0_CH1, I2C2_SMBA, SPI1_SCK, I2S1_CK, USART0_TX, SDIO_D2, DCI_D0, EVENTOUT Additional: USBFS_VBUS
PA10	43	I/O	5VT	Default: PA10 Alternate: TIMER0_CH2, USART0_RX, USBFS_ID, DCI_D1, EVENTOUT, I2C2_TXFRAME
PA11	44	I/O	5VT	Default: PA11 Alternate: TIMER0_CH3, USART0_CTS, USART5_TX, CAN0_RX, USBFS_DM, EVENTOUT
PA12	45	I/O	5VT	Default: PA12 Alternate: TIMER0_ETI, USART0_RTS, USART5_RX,

GD32F427Rx LQFP64				
Pin Name	Pins	Pin Type ⁽¹⁾	I/O Level ⁽²⁾	Functions description
				CAN0_TX, USBFS_DP, EVENTOUT
PA13	46	I/O	5VT	Default: JTMS, SWDIO, PA13 Alternate: EVENTOUT
VDD	48	P	-	Default: VDD
PA14	49	I/O	5VT	Default: JTCK, SWCLK, PA14 Alternate: EVENTOUT
PA15	50	I/O	5VT	Default: JTDI, PA15 Alternate: TIMER1_CH0, TIMER1_ETI, SPI0_NSS, SPI2_NSS, I2S2_WS, USART0_TX, EVENTOUT
PC10	51	I/O	5VT	Default: PC10 Alternate: SPI2_SCK, I2S2_CK, USART2_TX, UART3_TX, SDIO_D2, DCI_D8, EVENTOUT
PC11	52	I/O	5VT	Default: PC11 Alternate: I2S2_ADD_SD, SPI2_MISO, USART2_RX, UART3_RX, SDIO_D3, DCI_D4, EVENTOUT
PC12	53	I/O	5VT	Default: PC12 Alternate: I2C1_SDA, SPI2_MOSI, I2S2_SD, USART2_CK, UART4_TX, SDIO_CK, DCI_D9, EVENTOUT
PD2	54	I/O	5VT	Default: PD2 Alternate: TIMER2_ETI, UART4_RX, SDIO_CMD, DCI_D11, EVENTOUT
PB3	55	I/O	5VT	Default: JTDO, PB3 Alternate: TRACESWO, TIMER1_CH1, SPI0_SCK, SPI2_SCK, I2S2_CK, USART0_RX, I2C1_SDA, EVENTOUT
PB4	56	I/O	5VT	Default: NJTRST, PB4 Alternate: TIMER2_CH0, SPI0_MISO, SPI2_MISO, I2S2_ADD_SD, I2C2_SDA, SDIO_D0, EVENTOUT, I2C0_TXFRAME
PB5	57	I/O	5VT	Default: PB5 Alternate: TIMER2_CH1, I2C0_SMBA, SPI0_MOSI, SPI2_MOSI, I2S2_SD, CAN1_RX, USBHS_ULPI_D7, ENET_PPS_OUT, DCI_D10, EVENTOUT
PB6	58	I/O	5VT	Default: PB6 Alternate: TIMER3_CH0, I2C0_SCL, USART0_TX, CAN1_TX, DCI_D5, EVENTOUT
PB7	59	I/O	5VT	Default: PB7 Alternate: TIMER3_CH1, I2C0_SDA, USART0_RX, DCI_VSYNC, EVENTOUT
BOOT0	60	I/O	5VT	Default: BOOT0
PB8	61	I/O	5VT	Default: PB8

GD32F427Rx LQFP64				
Pin Name	Pins	Pin Type ⁽¹⁾	I/O Level ⁽²⁾	Functions description
				Alternate: TIMER1_CH0, TIMER1_ETI, TIMER3_CH2, TIMER9_CH0, I2C0_SCL, CAN0_RX, ENET_MII_TXD3, SDIO_D4, DCI_D6, EVENTOUT
PB9	62	I/O	5VT	Default: PB9 Alternate: TIMER1_CH1, TIMER3_CH3, TIMER10_CH0, I2C0_SDA, SPI1_NSS, I2S1_WS, CAN0_TX, SDIO_D5, DCI_D7, EVENTOUT
VSS	63	P	-	Default: VSS
VDD	64	P	-	Default: VDD

Notes:

(1) Type: I = input, O = output, P = power.

(2) I/O Level: 5VT = 5 V tolerant.

Pin Name	AF0	AF1	AF2	AF3	AF4	AF5	AF6	AF7	AF8	AF9	AF10	AF11	AF12	AF13	AF14	AF15
PA14	JTCK/SW CLK															EVENTOUT
PA15	JTDI	TIMER1_C H0/TIMER1_ETI				SPI0_NSS	SPI2_NSS /I2S2_WS	USART0_TX								EVENTOUT

Table 2-10. Port B alternate functions summary

Pin Name	AF0	AF1	AF2	AF3	AF4	AF5	AF6	AF7	AF8	AF9	AF10	AF11	AF12	AF13	AF14	AF15
PB0		TIMER0_C H1_ON	TIMER2_C H2	TIMER7_C H1_ON				SPI2_MOSI /I2S2_SD			USBHS_U LPI_D1	ENET_MII_RXD2	SDIO_D1			EVENTOUT
PB1		TIMER0_C H2_ON	TIMER2_C H3	TIMER7_C H2_ON							USBHS_U LPI_D2	ENET_MII_RXD3	SDIO_D2			EVENTOUT
PB2		TIMER1_C H3						SPI2_MOSI /I2S2_SD			USBHS_U LPI_D4		SDIO_CK			EVENTOUT
PB3	JTDO/TRACESWO	TIMER1_C H1				SPI0_SCK	SPI2_SCK /I2S2_CK	USART0_RX		I2C1_SDA						EVENTOUT
PB4	NJTRST		TIMER2_C H0		I2C0_TXF RAME	SPI0_MISO	SPI2_MISO	I2S2_ADD_SD		I2C2_SDA			SDIO_D0			EVENTOUT
PB5			TIMER2_C H1		I2C0_SMB A	SPI0_MOSI	SPI2_MOSI /I2S2_SD			CAN1_RX	USBHS_U LPI_D7	ENET_PPS_OUT	EXMC_SDCKE1	DCI_D10		EVENTOUT
PB6			TIMER3_C H0		I2C0_SCL			USART0_TX		CAN1_TX			EXMC_SDNE1	DCI_D5		EVENTOUT
PB7			TIMER3_C H1		I2C0_SDA			USART0_RX					EXMC_NL/EXMC_NADV	DCI_VSYNC		EVENTOUT
PB8		TIMER1_C H0/TIMER1_ETI	TIMER3_C H2	TIMER9_C H0	I2C0_SCL					CAN0_RX		ENET_MII_TXD3	SDIO_D4	DCI_D6		EVENTOUT
PB9		TIMER1_C H1	TIMER3_C H3	TIMER10_CH0	I2C0_SDA	SPI1_NSS /I2S1_WS				CAN0_TX			SDIO_D5	DCI_D7		EVENTOUT
PB10		TIMER1_C H2			I2C1_SCL	SPI1_SCK /I2S1_CK	I2S2_MCK	USART2_TX			USBHS_U LPI_D3	ENET_MII_RX_ER	SDIO_D7			EVENTOUT
PB11		TIMER1_C H3			I2C1_SDA	I2S_CKIN		USART2_RX			USBHS_U LPI_D4	ENET_MII_TX_EN/ENET_RMII_TX_EN				EVENTOUT
PB12		TIMER0_BRKIN			I2C1_SMB A	SPI1_NSS /I2S1_WS		USART2_CK		CAN1_RX	USBHS_U LPI_D5	ENET_MII_TXD0/ENET_RMII_TXD0	USBHS_ID			EVENTOUT

Pin Name	AF0	AF1	AF2	AF3	AF4	AF5	AF6	AF7	AF8	AF9	AF10	AF11	AF12	AF13	AF14	AF15
PB13		TIMER0_C H0_ON			I2C1_TXF RAME	SPI1_SCK /I2S1_CK		USART2_C TS		CAN1_TX	USBHS_U LPI_D6	ENET_MII_ TXD1/ENET _RMII_TXD 1				EVENTOUT
PB14		TIMER0_C H1_ON		TIMER7_C H1_ON		SPI1_MIS O	I2S1_ADD _SD	USART2_R TS		TIMER11_ CH0			USBHS_ DM			EVENTOUT
PB15	RTC_REFI N	TIMER0_C H2_ON		TIMER7_C H2_ON		SPI1_MO SI/I2S1_S D				TIMER11_ CH1			USBHS_ DP			EVENTOUT

Table 2-11. Port C alternate functions summary

Pin Name	AF0	AF1	AF2	AF3	AF4	AF5	AF6	AF7	AF8	AF9	AF10	AF11	AF12	AF13	AF14	AF15
PC0											USBHS_U LPI_STP		EXMC_SD NWE			EVENTOU T
PC1						SPI2_MO SI/I2S2_S D		SPI1_MO SI/I2S1_S D				ENET_MD C				EVENTOU T
PC2						SPI1_MIS O	I2S1_ADD _SD				USBHS_U LPI_DIR	ENET_MII_ TXD2	EXMC_SD NE0			EVENTOU T
PC3						SPI1_MO SI/I2S1_S D					USBHS_U LPI_NXT	ENET_MII_ TX_CLK	EXMC_SD CKE0			EVENTOU T
PC4												ENET_MII_ RXD0/EN ET_RMII_ RXD0	EXMC_SD NE0			EVENTOU T
PC5								USART2_ RX				ENET_MII_ RXD1/EN ET_RMII_ RXD1	EXMC_SD CKE0			EVENTOU T
PC6			TIMER2_C H0	TIMER7_C H0		I2S1_MCK			USART5_ TX				SDIO_D6	DCI_D0		EVENTOU T
PC7			TIMER2_C H1	TIMER7_C H1		SPI1_SCK /I2S1_CK	I2S2_MCK		USART5_ RX				SDIO_D7	DCI_D1		EVENTOU T
PC8			TIMER2_C H2	TIMER7_C H2					USART5_ CK				SDIO_D0	DCI_D2		EVENTOU T
PC9	CK_OUT1		TIMER2_C H3	TIMER7_C H3	I2C2_SDA	I2S_CKIN							SDIO_D1	DCI_D3		EVENTOU T
PC10							SPI2_SCK /I2S2_CK	USART2_ TX	UART3_T X				SDIO_D2	DCI_D8		EVENTOU T

Pin Name	AF0	AF1	AF2	AF3	AF4	AF5	AF6	AF7	AF8	AF9	AF10	AF11	AF12	AF13	AF14	AF15
PC11						I2S2_ADD_SD	SPI2_MISO	USART2_RX	UART3_RX				SDIO_D3	DCI_D4		EVENTOUT
PC12					I2C1_SDA		SPI2_MOSI/I2S2_SD	USART2_CK	UART4_TX				SDIO_CK	DCI_D9		EVENTOUT
PC13																EVENTOUT
PC14																EVENTOUT
PC15																EVENTOUT

Table 2-12. Port D alternate functions summary

Pin Name	AF0	AF1	AF2	AF3	AF4	AF5	AF6	AF7	AF8	AF9	AF10	AF11	AF12	AF13	AF14	AF15
PD0							SPI2_MOSI/I2S2_SD			CAN0_RX			EXMC_D2			EVENTOUT
PD1								SPI1_NSS/I2S1_WS		CAN0_TX			EXMC_D3			EVENTOUT
PD2			TIMER2_ETI						UART4_RX				SDIO_CKD	DCI_D11		EVENTOUT
PD3						SPI1_SCK/I2S1_CK		USART1_CTS					EXMC_CLK	DCI_D5		EVENTOUT
PD4								USART1_RTS					EXMC_NOE			EVENTOUT
PD5								USART1_TX					EXMC_NWE			EVENTOUT
PD6						SPI2_MOSI/I2S2_SD		USART1_RX					EXMC_NWAIT	DCI_D10		EVENTOUT
PD7								USART1_CK					EXMC_NE0/EXMC_NCE1			EVENTOUT
PD8								USART2_TX					EXMC_D13			EVENTOUT
PD9								USART2_RX					EXMC_D14			EVENTOUT

Pin Name	AF0	AF1	AF2	AF3	AF4	AF5	AF6	AF7	AF8	AF9	AF10	AF11	AF12	AF13	AF14	AF15
PD10								USART2_ CK					EXMC_D15			EVENTOUT
PD11								USART2_ CTS					EXMC_A16/EXMC_ CLE			EVENTOUT
PD12			TIMER3_ C H0					USART2_ RTS					EXMC_A17/EXMC_ A LE			EVENTOUT
PD13			TIMER3_ C H1										EXMC_A18			EVENTOUT
PD14			TIMER3_ C H2										EXMC_D0			EVENTOUT
PD15	CTC_ SYN C		TIMER3_ C H3										EXMC_D1			EVENTOUT

Table 2-13. Port E alternate functions summary

Pin Name	AF0	AF1	AF2	AF3	AF4	AF5	AF6	AF7	AF8	AF9	AF10	AF11	AF12	AF13	AF14	AF15
PE0			TIMER3_ E TI										EXMC_ NB L0	DCI_ D2		EVENTOUT
PE1		TIMER0_ C H1_ ON											EXMC_ NB L1	DCI_ D3		EVENTOUT
PE2												ENET_ MII _ TXD3	EXMC_ A23			EVENTOUT
PE3													EXMC_ A19			EVENTOUT
PE4													EXMC_ A20	DCI_ D4		EVENTOUT
PE5				TIMER8_ C H0									EXMC_ A21	DCI_ D6		EVENTOUT
PE6				TIMER8_ C H1									EXMC_ A22	DCI_ D7		EVENTOUT
PE7		TIMER0_ E TI											EXMC_ D4			EVENTOUT
PE8		TIMER0_ C H0_ ON											EXMC_ D5			EVENTOUT
PE9		TIMER0_ C H0											EXMC_ D6			EVENTOUT

Pin Name	AF0	AF1	AF2	AF3	AF4	AF5	AF6	AF7	AF8	AF9	AF10	AF11	AF12	AF13	AF14	AF15
PE10		TIMER0_C H1_ON											EXMC_D7			EVENTOU T
PE11		TIMER0_C H1											EXMC_D8			EVENTOU T
PE12		TIMER0_C H2_ON											EXMC_D9			EVENTOU T
PE13		TIMER0_C H2											EXMC_D1 0			EVENTOU T
PE14		TIMER0_C H3											EXMC_D1 1			EVENTOU T
PE15		TIMER0_B RKIN											EXMC_D1 2			EVENTOU T

Table 2-14. Port F alternate functions summary

Pin Name	AF0	AF1	AF2	AF3	AF4	AF5	AF6	AF7	AF8	AF9	AF10	AF11	AF12	AF13	AF14	AF15
PF0	CTC_SYN C				I2C1_SDA								EXMC_A0			EVENTOU T
PF1					I2C1_SCL								EXMC_A1			EVENTOU T
PF2					I2C1_SMB A								EXMC_A2			EVENTOU T
PF3					I2C1_TXF RAME								EXMC_A3			EVENTOU T
PF4													EXMC_A4			EVENTOU T
PF5													EXMC_A5			EVENTOU T
PF6				TIMER9_C H0									EXMC_NI ORD			EVENTOU T
PF7				TIMER10_ CH0									EXMC_NR EG			EVENTOU T
PF8										TIMER12_ CH0			EXMC_NI OWR			EVENTOU T
PF9										TIMER13_ CH0			EXMC_CD			EVENTOU T
PF10													EXMC_IN TR	DCI_D11		EVENTOU T

Pin Name	AF0	AF1	AF2	AF3	AF4	AF5	AF6	AF7	AF8	AF9	AF10	AF11	AF12	AF13	AF14	AF15
PF11													EXMC_SD NRAS	DCI_D12		EVENTOU T
PF12													EXMC_A6			EVENTOU T
PF13													EXMC_A7			EVENTOU T
PF14													EXMC_A8			EVENTOU T
PF15													EXMC_A9			EVENTOU T

Table 2-15. Port G alternate functions summary

Pin Name	AF0	AF1	AF2	AF3	AF4	AF5	AF6	AF7	AF8	AF9	AF10	AF11	AF12	AF13	AF14	AF15
PG0													EXMC_A1 0			EVENTOU T
PG1													EXMC_A1 1			EVENTOU T
PG2													EXMC_A1 2			EVENTOU T
PG3													EXMC_A1 3			EVENTOU T
PG4													EXMC_A1 4			EVENTOU T
PG5													EXMC_A1 5			EVENTOU T
PG6													EXMC_IN T1	DCI_D12		EVENTOU T
PG7									USART5_ CK				EXMC_IN T2	DCI_D13		EVENTOU T
PG8									USART5_ RTS			ENET_PP S_OUT	EXMC_SD CLK			EVENTOU T
PG9									USART5_ RX				EXMC_NE 1/EXMC_N CE2	DCI_VSYN C		EVENTOU T
PG10													EXMC_NC E3_0/EXM C_NE2	DCI_D2		EVENTOU T

Pin Name	AF0	AF1	AF2	AF3	AF4	AF5	AF6	AF7	AF8	AF9	AF10	AF11	AF12	AF13	AF14	AF15
PG11												ENET_MII_TX_EN/ENET_RMII_TX_EN	EXMC_NCE3_1	DCI_D3		EVENTOUT
PG12									USART5_RTS				EXMC_NE3			EVENTOUT
PG13									USART5_CTS			ENET_MII_TXD0/ENET_RMII_TXD0	EXMC_A24			EVENTOUT
PG14									USART5_TX			ENET_MII_TXD1/ENET_RMII_TXD1	EXMC_A25			EVENTOUT
PG15									USART5_CTS				EXMC_SDNCS	DCI_D13		EVENTOUT

Table 2-16. Port H alternate functions summary

Pin Name	AF0	AF1	AF2	AF3	AF4	AF5	AF6	AF7	AF8	AF9	AF10	AF11	AF12	AF13	AF14	AF15
PH0																EVENTOUT
PH1																EVENTOUT
PH2												ENET_MII_CRS	EXMC_SDCKE0			EVENTOUT
PH3					I2C1_TXFRAME							ENET_MII_COL	EXMC_SDCNE0			EVENTOUT
PH4					I2C1_SCL						USBHS_ULPI_NXT					EVENTOUT
PH5					I2C1_SDA								EXMC_SDNWE			EVENTOUT
PH6					I2C1_SMB_A					TIMER11_CH0		ENET_MII_RXD2	EXMC_SDCNE1	DCI_D8		EVENTOUT
PH7					I2C2_SCL							ENET_MII_RXD3	EXMC_SDCKE1	DCI_D9		EVENTOUT
PH8					I2C2_SDA								EXMC_D16	DCI_HSYNC		EVENTOUT

PH9					I2C2_SMB A					TIMER11_ CH1			EXMC_D1 7	DCI_D0		EVENTOU T
PH10			TIMER4_C H0		I2C2_TXF RAME								EXMC_D1 8	DCI_D1		EVENTOU T
PH11			TIMER4_C H1										EXMC_D1 9	DCI_D2		EVENTOU T
PH12			TIMER4_C H2										EXMC_D2 0	DCI_D3		EVENTOU T
PH13				TIMER7_C H0_ON						CAN0_TX			EXMC_D2 1			EVENTOU T
PH14				TIMER7_C H1_ON									EXMC_D2 2	DCI_D4		EVENTOU T
PH15				TIMER7_C H2_ON									EXMC_D2 3	DCI_D11		EVENTOU T

Table 2-17. Port I alternate functions summary

Pin Name	AF0	AF1	AF2	AF3	AF4	AF5	AF6	AF7	AF8	AF9	AF10	AF11	AF12	AF13	AF14	AF15
PI0			TIMER4_C H3			SPI1_NSS /I2S1_WS							EXMC_D2 4	DCI_D13		EVENTOU T
PI1						SPI1_SCK /I2S1_CK							EXMC_D2 5	DCI_D8		EVENTOU T
PI2				TIMER7_C H3		SPI1_MIS O	I2S1_ADD _SD						EXMC_D2 6	DCI_D9		EVENTOU T
PI3				TIMER7_E TI		SPI1_MOS I/I2S1_SD							EXMC_D2 7	DCI_D10		EVENTOU T
PI4				TIMER7_B RKIN									EXMC_NB L2	DCI_D5		EVENTOU T
PI5				TIMER7_C H0									EXMC_NB L3	DCI_VSYN C		EVENTOU T
PI6				TIMER7_C H1									EXMC_D2 8	DCI_D6		EVENTOU T
PI7				TIMER7_C H2									EXMC_D2 9	DCI_D7		EVENTOU T
PI8																EVENTOU T
PI9										CAN0_RX			EXMC_D3 0			EVENTOU T



Pin Name	AF0	AF1	AF2	AF3	AF4	AF5	AF6	AF7	AF8	AF9	AF10	AF11	AF12	AF13	AF14	AF15
P110												ENET_MII _RX_ER	EXMC_D3 1			EVENTOU T
P111											USBHS_U LPI_DIR					EVENTOU T

3. Functional description

3.1. Arm[®] Cortex[®]-M4 core

The Arm[®] Cortex[®]-M4 processor is a high performance embedded processor with DSP instructions which allow efficient signal processing and complex algorithm execution. It brings an efficient, easy-to-use blend of control and signal processing capabilities to meet the digital signal control markets demand. The processor is highly configurable enabling a wide range of implementations from those requiring floating point operations, memory protection and powerful trace technology to cost sensitive devices requiring minimal area, while delivering outstanding computational performance and an advanced system response to interrupts.

32-bit Arm[®] Cortex[®]-M4 processor core

- Up to 200 MHz operation frequency
- Single-cycle multiplication and hardware divider
- Floating Point Unit (FPU)
- Integrated DSP instructions
- Integrated Nested Vectored Interrupt Controller (NVIC)
- 24-bit SysTick timer

The Cortex[®]-M4 processor is based on the Armv7-M architecture and supports both Thumb and Thumb-2 instruction sets. Some system peripherals listed below are also provided by Cortex[®]-M4:

- Internal Bus Matrix connected with ICode bus, DCode bus, system bus, Private Peripheral Bus (PPB) and debug accesses (AHB-AP)
- Nested Vectored Interrupt Controller (NVIC)
- Flash Patch and Breakpoint (FPB)
- Data Watchpoint and Trace (DWT)
- Instrument Trace Macrocell (ITM)
- Memory Protection Unit (MPU)
- Serial Wire JTAG Debug Port (SWJ-DP)
- Trace Port Interface Unit (TPIU)

3.2. On-chip memory

- Up to 3072 Kbytes of Flash memory, including code Flash and data Flash
- The region of the MCU executing instructions without waiting time is up to 512K bytes (in case that Flash size equal to 512K, all memory is no waiting time). A long delay when CPU fetches the instructions out of the range.
- 256 KB of SRAM

The Arm[®] Cortex[®]-M4 processor is structured in Harvard architecture which can use separate

buses to fetch instructions and load/store data. 3072 Kbytes of inner Flash at most, which includes code Flash and data Flash is available for storing programs and data, and there is no waiting time within code Flash area when CPU executes instructions. Up to 256 Kbytes of inner SRAM is composed of SRAM0 (112KB), SRAM1 (16KB) and SRAM2 (64KB) that can be accessed at same time, and including 64 KB of TCM (tightly-coupled memory) data RAM that can be accessed only by the data bus of the Cortex®-M4 core. The additional 4KB of backup SRAM (BKP SRAM) is implemented in the backup domain, which can keep its content even when the V_{DD} power supply is down. [Table 2-3. GD32F427xx memory map](#) shows the memory map of the GD32F427xx series of devices, including Flash, SRAM, peripheral, and other pre-defined regions.

3.3. Clock, reset and supply management

- Internal 16 MHz factory-trimmed RC and external 4 to 32 MHz crystal oscillator
- Internal 48 MHz RC oscillator
- Internal 32 KHz RC calibrated oscillator and external 32.768 KHz crystal oscillator
- Integrated system clock PLL
- 2.6 to 3.6 V application supply and I/Os
- Supply Supervisor: POR (Power On Reset), PDR (Power Down Reset), and low voltage detector (LVD)

The Clock Control Unit (CCU) provides a range of oscillator and clock functions. These include internal RC oscillator and external crystal oscillator, high speed and low speed two types. Several prescalers allow the frequency configuration of the AHB and two APB domains. The maximum frequency of the two AHB domains are 200 MHz. The maximum frequency of the two APB domains including APB1 is 50 MHz and APB2 is 100 MHz. See [Figure 2-7. GD32F427xx clock tree](#) for details on the clock tree.

The Reset Control Unit (RCU) controls three kinds of reset: system reset resets the processor core and peripheral IP components. Power-on reset (POR) and power-down reset (PDR) are always active, and ensures proper operation starting from 2.4 V and down to 1.8V. The device remains in reset mode when V_{DD} is below a specified threshold. The embedded low voltage detector (LVD) monitors the power supply, compares it to the voltage threshold and generates an interrupt as a warning message for leading the MCU into security.

Power supply schemes:

- V_{DD} range: 2.6 to 3.6 V, external power supply for I/Os and the internal regulator. Provided externally through VDD pins.
- V_{SSA} , V_{DDA} range: 2.6 to 3.6 V, external analog power supplies for ADC, reset blocks, RCs and PLL. V_{DDA} and V_{SSA} must be connected to VDD and VSS, respectively.
- V_{BAT} range: 1.8 to 3.6 V, power supply for RTC, external clock 32 KHz oscillator and backup registers (through power switch) when V_{DD} is not present.

3.4. Boot modes

At startup, boot pins are used to select one of three boot options:

- Boot from main Flash memory (default)
- Boot from system memory
- Boot from on-chip SRAM

The boot loader is located in the internal 30KB of information blocks for the boot ROM memory (system memory). It is used to reprogram the Flash memory by using USART0 (PA9 and PA10), USART2 (PB10 and PB11, or PC10 and PC11), and USBFS (PA9, PA10, PA11 and PA12) in device mode. It also can be used to transfer and update the Flash memory code, the data and the vector table sections. In default condition, boot from bank 0 of Flash memory is selected. It also supports to boot from bank 1 of Flash memory by setting a bit in option bytes.

3.5. Power saving modes

The MCU supports three kinds of power saving modes to achieve even lower power consumption. They are sleep mode, deep-sleep mode, and standby mode. These operating modes reduce the power consumption and allow the application to achieve the best balance between the CPU operating time, speed and power consumption.

- **Sleep mode**

In sleep mode, only the clock of CPU core is off. All peripherals continue to operate and any interrupt/event can wake up the system.

- **Deep-sleep mode**

In deep-sleep mode, all clocks in the 1.2V domain are off, and all of the high speed crystal oscillator (IRC16M, HXTAL) and PLL are disabled. Only the contents of SRAM and registers are retained. Any interrupt or wakeup event from EXTI lines can wake up the system from the deep-sleep mode including the 16 external lines, the RTC alarm, RTC Tamper and TimeStamp event, the LVD output, ENET wakeup, RTC wakeup and USB wakeup. When exiting the deep-sleep mode, the IRC16M is selected as the system clock.

- **Standby mode**

In standby mode, the whole 1.2V domain is power off, the LDO is shut down, and all of IRC16M, HXTAL and PLL are disabled. The contents of SRAM and registers (except backup registers) are lost. There are four wakeup sources for the standby mode, including the external reset from NRST pin, the RTC, the FWDGT reset, and the rising edge on WKUP pin.

3.6. Analog to digital converter (ADC)

- 12-bit SAR ADC's conversion rate is up to 2.6 MSPS

- 12-bit, 10-bit, 8-bit or 6-bit configurable resolution
- Hardware oversampling ratio adjustable from 2x to 256x improves resolution to 16-bit
- Input voltage range: V_{SSA} to V_{DDA} ($2.6\text{ V} \leq V_{DDA} \leq 3.6\text{ V}$)
- Temperature sensor

Up to three 12-bit 2.6 MSPS multi-channel ADCs are integrated in the device. It has a total of 19 multiplexed channels: 16 external channels, 1 channel for internal temperature sensor (V_{SENSE}), 1 channel for internal reference voltage (V_{REFINT}) and 1 channel for external battery power supply (V_{BAT}). The input voltage range is between 2.6 V and 3.6 V. An on-chip hardware oversampling scheme improves performance while off-loading the related computational burden from the CPU. An analog watchdog block can be used to detect the channels, which are required to remain within a specific threshold window. A configurable channel management block can be used to perform conversions in single, continuous, scan or discontinuous mode to support more advanced use.

The ADC can be triggered from the events generated by the general level 0 timers (TIMERx) and the advanced timers (TIMER0 and TIMER7) with internal connection. The temperature sensor can be used to generate a voltage that varies linearly with temperature. It is internally connected to the ADC_IN16 input channel which is used to convert the sensor output voltage in a digital value.

3.7. Digital to analog converter (DAC)

- Two 12-bit DAC converter of independent output channel
- 8-bit or 12-bit mode in conjunction with the DMA controller

The two 12-bit buffered DACs are used to generate variable analog outputs. The DAC channels can be triggered by the timer or EXTI with DMA support. In dual DAC channel operation, conversions could be done independently or simultaneously. The maximum output value of the DAC is VREFP.

3.8. DMA

- 16 channels DMA controller and each channel are configurable (8 for DMA0 and 8 for DMA1)
- Support independent 8, 16, 32-bit memory and peripheral transfer
- Peripherals supported: Timers, ADC, SPIs, I2Cs, USARTs, UARTs, DAC, I2S, SDIO and DCI

The flexible general-purpose DMA controllers provide a hardware method of transferring data between peripherals and/or memory without intervention from the CPU, thereby freeing up bandwidth for other system functions. Three types of access method are supported: peripheral to memory, memory to peripheral, memory to memory.

Each channel is connected to fixed hardware DMA requests. The priorities of DMA channel

requests are determined by software configuration and hardware channel number. Transfer size of source and destination are independent and configurable.

3.9. General-purpose inputs/outputs (GPIOs)

- Up to 140 fast GPIOs, all mappable on 16 external interrupt lines
- Analog input/output configurable
- Alternate function input/output configurable

There are up to 140 general purpose I/O pins (GPIO) in GD32F427xx, named PA0 ~ PA15, PB0 ~ PB15, PC0 ~ PC15, PD0 ~ PD15, PE0 ~ PE15, PF0 ~ PF15, PG0 ~ PG15, PH0 ~ PH15 and PI0 ~ PI11 to implement logic input/output functions. Each of the GPIO ports has related control and configuration registers to satisfy the requirements of specific applications. The external interrupts on the GPIO pins of the device have related control and configuration registers in the Interrupt/event controller (EXTI). The GPIO ports are pin-shared with other alternative functions (AFs) to obtain maximum flexibility on the package pins. Each of the GPIO pins can be configured by software as output (push-pull or open-drain), as input (with or without pull-up or pull-down) or as peripheral alternate function. Most of the GPIO pins are shared with digital or analog alternate functions. All GPIOs are high-current capable except for analog inputs.

3.10. Timers and PWM generation

- Two 16-bit advanced timer (TIMER0 & TIMER7), eight 16-bit general timers (TIMER2, TIMER3, TIMER8 ~ TIMER13), two 32-bit general timers (TIMER1 & TIMER4) and two 16-bit basic timer (TIMER5 & TIMER6)
- Up to 4 independent channels of PWM, output compare or input capture for each general timer and external trigger input
- 16-bit, motor control PWM advanced timer with programmable dead-time generation for output match
- Encoder interface controller with two inputs using quadrature decoder
- 24-bit SysTick timer down counter
- 2 watchdog timers (free watchdog timer and window watchdog timer)

The advanced timer (TIMER0 & TIMER7) can be used as a three-phase PWM multiplexed on 6 channels. It has complementary PWM outputs with programmable dead-time generation. It can also be used as a complete general timer. The 4 independent channels can be used for input capture, output compare, PWM generation (edge-aligned or center-aligned counting modes) and single pulse mode output. If configured as a general 16-bit timer, it has the same functions as the TIMEx timer. It can be synchronized with external signals or to interconnect with other general timers together which have the same architecture and features.

The general timer, can be used for a variety of purposes including general time, input signal pulse width measurement or output waveform generation such as a single pulse generation

or PWM output, up to 4 independent channels for input capture/output compare. TIMER1 & TIMER4 is based on a 32-bit auto-reload up/downcounter and a 16-bit prescaler. TIMER2 & TIMER3 is based on a 16-bit auto-reload up/downcounter and a 16-bit prescaler. TIMER8 ~ TIMER13 is based on a 16-bit auto-reload upcounter and a 16-bit prescaler. The general timer also supports an encoder interface with two inputs using quadrature decoder.

The basic timer, known as TIMER5 & TIMER6, are mainly used for DAC trigger generation. They can also be used as a simple 16-bit time base.

The GD32F427xx have two watchdog peripherals, free watchdog timer and window watchdog timer. They offer a combination of high safety level, flexibility of use and timing accuracy.

The free watchdog timer includes a 12-bit down-counting counter and an 8-bit prescaler. It is clocked from an independent 32 KHz internal RC and as it operates independently of the main clock, it can operate in deep-sleep and standby modes. It can be used either as a watchdog to reset the device when a problem occurs, or as a free-running timer for application timeout management.

The window watchdog timer is based on a 7-bit down counter that can be set as free-running. It can be used as a watchdog to reset the device when a problem occurs. It is clocked from the main clock. It has an early wakeup interrupt capability and the counter can be frozen in debug mode.

The SysTick timer is dedicated for OS, but could also be used as a standard down counter. It features:

- A 24-bit down counter
- Auto reload capability
- Maskable system interrupt generation when the counter reaches 0
- Programmable clock source

3.11. Real time clock (RTC) and backup registers

- Independent binary-coded decimal (BCD) format timer/counter with twenty 32-bit backup registers
- Calendar with sub-second, seconds, minutes, hours, week day, date, year and month automatically correction
- Alarm function with wake up from deep-sleep and standby mode capability
- On-the-fly correction for synchronization with master clock. Digital calibration with 1 ppm resolution for compensation of quartz crystal inaccuracy

The real time clock is an independent timer which provides a set of continuously running counters in backup registers to provide a real calendar function, and provides an alarm interrupt or an expected interrupt. It is not reset by a system or power reset, or when the device wakes up from standby mode. A prescaler is used for the time base clock and is by default configured to generate a time base of 1 second from a clock at 32.768 KHz from external crystal oscillator.

3.12. Inter-integrated circuit (I2C)

- Up to three I2C bus interfaces can support both master and slave mode with a frequency up to 400 KHz (Fast mode)
- Provide arbitration function, optional PEC (packet error checking) generation and checking
- Supports 7-bit and 10-bit addressing mode and general call addressing mode

The I2C interface is an internal circuit allowing communication with an external I2C interface which is an industry standard two line serial interface used for connection to external hardware. These two serial lines are known as a serial data line (SDA) and a serial clock line (SCL). The I2C module provides transfer rate of up to 100 KHz in standard mode and up to 400 KHz in fast mode. The I2C module also has an arbitration detect function to prevent the situation where more than one master attempts to transmit data to the I2C bus at the same time. A CRC-8 calculator is also provided in I2C interface to perform packet error checking for I2C data.

3.13. Serial peripheral interface (SPI)

- Master or slave operation with full-duplex or simplex mode
- Support both master and slave mode
- Hardware CRC calculation and transmit automatic CRC error checking

The SPI interface uses 4 pins, among which are the serial data input and output lines (MISO & MOSI), the clock line (SCK) and the slave select line (NSS). Both SPIs can be served by the DMA controller. The SPI interface may be used for a variety of purposes, including simplex synchronous transfers on two lines with a possible bidirectional data line or reliable communication using CRC checking.

3.14. Universal synchronous/asynchronous receiver transmitter (USART/UART)

- Maximum speed up to 12.5MBit/s for USART0 and USART5
- Maximum speed up to 6.25MBit/s for USART1, USART2, UART3 and UART4
- Supports both asynchronous and clocked synchronous serial communication modes
- IrDA SIR encoder and decoder support
- LIN break generation and detection
- ISO 7816-3 compliant smart card interface

The USART (USART0, USART1, USART2, USART5) and UART (UART3, UART4) are used to transfer data between parallel and serial interfaces, provides a flexible full duplex data exchange using synchronous or asynchronous transfer. It is also commonly used for RS-232

standard communication. The USART/UART includes a programmable baud rate generator which is capable of dividing the system clock to produce a dedicated clock for the USART/UART transmitter and receiver. The USART/UART also supports DMA function for high speed data communication.

3.15. Inter-IC sound (I2S)

- Two I2S bus Interfaces with sampling frequency from 8 KHz to 192 KHz, multiplexed with SPI1 and SPI2
- Support either master or slave mode Audio
- Sampling frequencies from 8 KHz up to 192 KHz are supported

The Inter-IC sound (I2S) bus provides a standard communication interface for digital audio applications by 4-wire serial lines. GD32F427xx contain an I2S-bus interface that can be operated with 16/32 bit resolution in master or slave mode, pin multiplexed with SPI1 and SPI2. The audio sampling frequencies from 8 KHz to 192 KHz is supported.

3.16. Universal serial bus full-speed interface (USBFS)

- One USB device/host/OTG full-speed Interface with frequency up to 12 Mbit/s
- Internal 48 MHz oscillator support crystal-less operation
- Internal main PLL for USB CLK compliantly
- Internal USBFS PHY support

The Universal Serial Bus (USB) is a 4-wire bus with 4 bidirectional endpoints. The device controller enables 12 Mbit/s data exchange with integrated transceivers. Transaction formatting is performed by the hardware, including CRC generation and checking. It supports both host and device modes, as well as OTG mode with Host Negotiation Protocol (HNP) and Session Request Protocol (SRP). The controller contains a full-speed USB PHY internal. For full-speed or low-speed operation, no more external PHY chip is needed. It supports all the four types of transfer (control, bulk, Interrupt and isochronous) defined in USB 2.0 protocol. The required precise 48 MHz clock which can be generated from the internal main PLL (the clock source must use an HXTAL crystal oscillator) or by the internal 48 MHz oscillator in automatic trimming mode that allows crystal-less operation.

3.17. Universal serial bus high-speed interface (USBHS)

- One USB device/host/OTG high-speed Interface with frequency up to 480 Mbit/s
- An external PHY device connected to the ULPI is required when using in HS mode

USBHS supports both host and device modes, as well as OTG mode with Host Negotiation Protocol (HNP) and Session Request Protocol (SRP). The controller provides ULPI interface for external USB PHY integration and it also contains a full-speed USB PHY internal. For full-

speed or low-speed operation, no more external PHY chip is needed. It supports all the four types of transfer (control, bulk, Interrupt and isochronous) defined in USB 2.0 protocol. HUB connection is supported when USBHS operates at high-speed in host mode. There is also a DMA engine operating as an AHB bus master in USBHS to speed up the data transfer between USBHS and system.

3.18. Controller area network (CAN)

- Two CAN2.0B interface with communication frequency up to 1 Mbit/s
- Internal main PLL for CAN CLK compliantly

Controller area network (CAN) is a method for enabling serial communication in field bus. The CAN protocol has been used extensively in industrial automation and automotive applications. It can receive and transmit standard frames with 11-bit identifiers as well as extended frames with 29-bit identifiers. Each CAN has three mailboxes for transmission and two FIFOs of three message deep for reception. It also provides 28 scalable/configurable identifier filter banks for selecting the incoming messages needed and discarding the others.

3.19. Ethernet (ENET)

- IEEE 802.3 compliant media access controller (MAC) for Ethernet LAN
- 10/100 Mbit/s rates with dedicated DMA controller and SRAM
- Support hardware precision time protocol (PTP) with conformity to IEEE 1588

The Ethernet media access controller (MAC) conforms to IEEE 802.3 specifications and fully supports IEEE 1588 standards. The embedded MAC provides the interface to the required external network physical interface (PHY) for LAN bus connection via an internal media independent interface (MII) or a reduced media independent interface (RMII). The number of MII signals provided up to 16 with 25 MHz output and RMII up to 7 with 50 MHz output. The function of 32-bit CRC checking is also available.

3.20. External memory controller (EXMC)

- Supported external memory: SRAM, PSRAM, ROM and NOR-Flash, NAND Flash and CF card, SDRAM with up to 32-bit data bus
- Provide ECC calculating hardware module for NAND Flash memory block
- Two SDRAM banks with independent configuration, up to 13-bits Row Address, 11-bits Column Address, 2-bits internal banks address
- SDRAM Memory size: 4x16Mx32bit (256 MB), 4x16Mx16bit (128 MB), 4x16Mx8bit (64 MB)

External memory controller (EXMC) is an abbreviation of external memory controller. It is divided in to several sub-banks for external device support, each sub-bank has its own chip

selection signal but at one time, only one bank can be accessed. The EXMC supports code execution from external memory except NAND Flash and CF card. The EXMC also can be configured to interface with the most common LCD module of Motorola 6800 and Intel 8080 series and reduce the system cost and complexity.

The EXMC of GD32F427xx in LQFP144 & BGA176 package also supports synchronous dynamic random access memory (SDRAM). It translates AHB transactions into the appropriate SDRAM protocol, and meanwhile, makes sure the access time requirements of the external SDRAM devices are satisfied.

3.21. Secure digital input and output card interface (SDIO)

- Support SD2.0/SDIO2.0/MMC4.2 host interface

The Secure Digital Input and Output Card Interface (SDIO) provides access to external SD memory cards specifications version 2.0, SDIO card specification version 2.0 and multi-media card system specification version 4.2 with DMA supported. In addition, this interface is also compliant with CE-ATA digital protocol rev1.1.

3.22. Digital camera interface (DCI)

- Digital video/picture capture
- 8/10/12/14 data width supported
- High transfer efficiency with DMA interface
- Video/picture crop supported
- Various pixel formats supported including JPEG/YCrCb/RGB
- Hard/embedded synchronous signals supported

DCI is an 8-bit to 14-bit parallel interface that able to capture video or picture from a camera via Digital Camera Interface. It supports 8/10/12/14 bits data width through DMA operation.

3.23. Debug mode

- Serial wire JTAG debug port (SWJ-DP)

The Arm® SWJ-DP Interface is embedded and is a combined JTAG and serial wire debug port that enables either a serial wire debug or a JTAG probe to be connected to the target.

3.24. Package and operation temperature

- BGA176 (GD32F427Ix), BGA100 (GDF427VxH), LQFP144 (GD32F427Zx), LQFP100 (GD32F427Vx) and LQFP64 (GD32F427Rx)
- Operation temperature range: -40°C to +85°C (industrial level)

4. Electrical characteristics

4.1. Absolute maximum ratings

The maximum ratings are the limits to which the device can be subjected without permanently damaging the device. Note that the device is not guaranteed to operate properly at the maximum ratings. Exposure to the absolute maximum rating conditions for extended periods may affect device reliability.

Table 4-1. Absolute maximum ratings⁽¹⁾⁽⁴⁾

Symbol	Parameter	Min	Max	Unit
V_{DD}	External voltage range ⁽²⁾	$V_{SS} - 0.3$	$V_{SS} + 3.6$	V
V_{DDA}	External analog supply voltage	$V_{SSA} - 0.3$	$V_{SSA} + 3.6$	V
V_{BAT}	External battery supply voltage	$V_{SS} - 0.3$	$V_{SS} + 3.6$	V
V_{IN}	Input voltage on 5V tolerant pin ⁽³⁾	$V_{SS} - 0.3$	$V_{DD} + 3.6$	V
	Input voltage on other I/O	$V_{SS} - 0.3$	3.6	V
$ \Delta V_{DDX} $	Variations between different VDD power pins	—	50	mV
$ V_{SSX} - V_{SS} $	Variations between different ground pins	—	50	mV
I_{IO}	Maximum current for GPIO pins	—	25	mA
T_A	Operating temperature range	-40	+85	°C
P_D	Power dissipation at $T_A = 85^\circ\text{C}$ of BGA176	—	888	mW
	Power dissipation at $T_A = 85^\circ\text{C}$ of LQFP144	—	820	
	Power dissipation at $T_A = 85^\circ\text{C}$ of BGA100	—	511	
	Power dissipation at $T_A = 85^\circ\text{C}$ of LQFP100	—	697	
	Power dissipation at $T_A = 85^\circ\text{C}$ of LQFP64	—	772	
T_{STG}	Storage temperature range	-65	+150	°C
T_J	Maximum junction temperature	—	125	°C

(1) Guaranteed by design, not tested in production.

(2) All main power and ground pins should be connected to an external power source within the allowable range.

(3) V_{IN} maximum value cannot exceed 5.5 V.

(4) It is recommended that V_{DD} and V_{DDA} are powered by the same source. The maximum difference between V_{DD} and V_{DDA} does not exceed 300 mV during power-up and operation.

4.2. Operating conditions characteristics

Table 4-2. DC operating conditions

Symbol	Parameter	Conditions	Min ⁽¹⁾	Typ	Max ⁽¹⁾	Unit
V_{DD}	Supply voltage	—	2.6	3.3	3.6	V
V_{DDA}	Analog supply voltage	Same as V_{DD}	2.6	3.3	3.6	V
V_{BAT}	Battery supply voltage	—	1.8 ⁽²⁾	—	3.6	V

(1) Based on characterization, not tested in production.

(2) In the application which V_{BAT} supply the backup domains, if the V_{BAT} voltage drops below the minimum value, when V_{DD} is powered on again, it is necessary to refresh the registers of backup domains and enable LXTAL

again.

Figure 4-1. Recommended power supply decoupling capacitors⁽¹⁾⁽²⁾

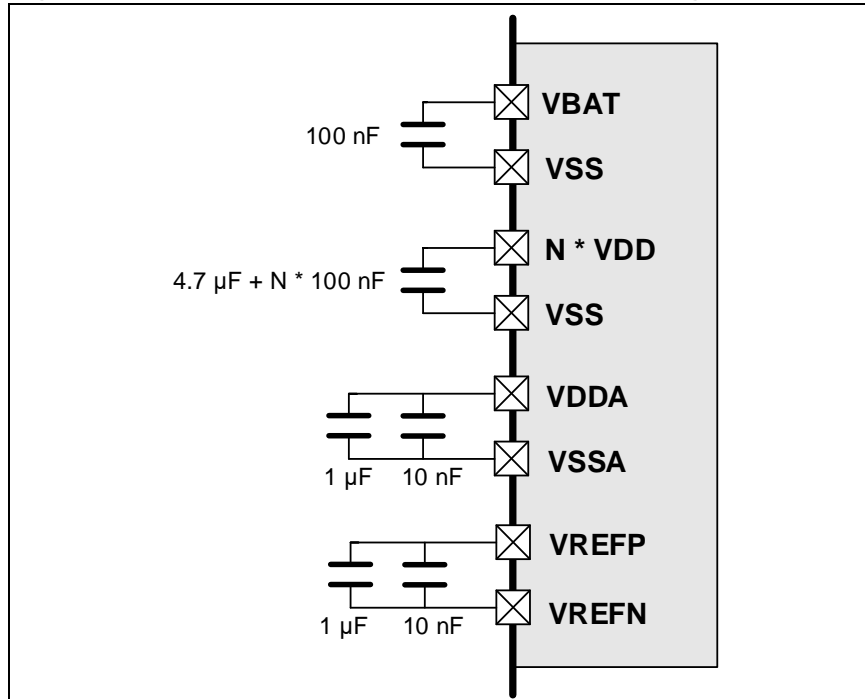

- (1) The VREFP and VREFN pins are only available on no less than 100-pin packages, or else the VREFP and VREFN pins are not available and internally connected to VDDA and VSSA pins. More details refer to **AN056 GD32F4xx Hardware Development Guide**.
- (2) All decoupling capacitors need to be as close as possible to the pins on the PCB board.

Table 4-3. Clock frequency⁽¹⁾

Symbol	Parameter	Conditions	Min	Max	Unit
f _{HCLK}	AHB clock frequency	—	—	200	MHz
f _{APB1}	APB1 clock frequency	—	—	50	MHz
f _{APB2}	APB2 clock frequency	—	—	100	MHz

- (1) Guaranteed by design, not tested in production.

Table 4-4. Operating conditions at Power up / Power down⁽¹⁾

Symbol	Parameter	Conditions	Min	Max	Unit
t _{VDD}	V _{DD} rise time rate	—	0	∞	μs/ V
	V _{DD} fall time rate		20	∞	

- (1) Guaranteed by design, not tested in production.

Table 4-5. Start-up timings of Operating conditions⁽¹⁾⁽²⁾⁽³⁾

Symbol	Parameter	Conditions	Typ	Unit
t _{start-up}	Start-up time	Clock source from HXTAL	140.6	ms
		Clock source from IRC16M	140.2	

- (1) Based on characterization, not tested in production.
- (2) After power-up, the start-up time is the time between the rising edge of NRST high and the main function.
- (3) PLL is off.

Table 4-6. Power saving mode wakeup timings characteristics⁽¹⁾⁽²⁾

Symbol	Parameter	Typ	Unit
t_{Sleep}	Wakeup from Sleep mode	0.623	μs
$t_{\text{Deep-sleep}}$	Wakeup from Deep-sleep mode (LDO On)	1.57	
	Wakeup from Deep-sleep mode (LDO in low power mode)	1.57	
t_{Standby}	Wakeup from Standby mode	140	ms

(1) Based on characterization, not tested in production.

(2) The wakeup time is measured from the wakeup event to the point at which the application code reads the first instruction under the below conditions: $V_{\text{DD}} = V_{\text{DDA}} = 3.3 \text{ V}$, $\text{IRC16M} = \text{System clock} = 16 \text{ MHz}$.

4.3. Power consumption

The power measurements specified in the tables represent that code with data executing from on-chip Flash with the following specifications.

Table 4-7. Power consumption characteristics⁽²⁾⁽³⁾⁽⁴⁾⁽⁵⁾⁽⁶⁾

Symbol	Parameter	Conditions	Min	Typ ⁽¹⁾	Max	Unit
$I_{\text{DD}}+I_{\text{DDA}}$	Supply current (Run mode)	$V_{\text{DD}} = V_{\text{DDA}} = 3.3 \text{ V}$, HXTAL = 25 MHz, System clock = 200 MHz, All peripherals enabled	—	61.5	—	mA
		$V_{\text{DD}} = V_{\text{DDA}} = 3.3 \text{ V}$, HXTAL = 25 MHz, System clock = 200 MHz, All peripherals disabled	—	37.1	—	mA
		$V_{\text{DD}} = V_{\text{DDA}} = 3.3 \text{ V}$, HXTAL = 25 MHz, System clock = 180 MHz, All peripherals enabled	—	55.9	—	mA
		$V_{\text{DD}} = V_{\text{DDA}} = 3.3 \text{ V}$, HXTAL = 25 MHz, System clock = 180 MHz, All peripherals disabled	—	33.9	—	mA
		$V_{\text{DD}} = V_{\text{DDA}} = 3.3 \text{ V}$, HXTAL = 25 MHz, System clock = 168 MHz, All peripherals enabled	—	52.6	—	mA
		$V_{\text{DD}} = V_{\text{DDA}} = 3.3 \text{ V}$, HXTAL = 25 MHz, System clock = 168 MHz, All peripherals disabled	—	32.0	—	mA
		$V_{\text{DD}} = V_{\text{DDA}} = 3.3 \text{ V}$, HXTAL = 25 MHz, System clock = 120 MHz, All peripherals enabled	—	38.6	—	mA
		$V_{\text{DD}} = V_{\text{DDA}} = 3.3 \text{ V}$, HXTAL = 25 MHz, System clock = 120 MHz, All peripherals disabled	—	23.9	—	mA
		$V_{\text{DD}} = V_{\text{DDA}} = 3.3 \text{ V}$, HXTAL = 25 MHz, System clock = 108 MHz, All peripherals enabled	—	35.2	—	mA

Symbol	Parameter	Conditions	Min	Typ ⁽¹⁾	Max	Unit
		V _{DD} = V _{DDA} = 3.3 V, HXTAL = 25 MHz, System clock = 108 MHz, All peripherals disabled	—	22.0	—	mA
		V _{DD} = V _{DDA} = 3.3 V, HXTAL = 25 MHz, System clock = 90 MHz, All peripherals enabled	—	29.9	—	mA
		V _{DD} = V _{DDA} = 3.3 V, HXTAL = 25 MHz, System clock = 90 MHz, All peripherals disabled	—	19.0	—	mA
		V _{DD} = V _{DDA} = 3.3 V, HXTAL = 25 MHz, System clock = 60 MHz, All peripherals enabled	—	21.2	—	mA
		V _{DD} = V _{DDA} = 3.3 V, HXTAL = 25 MHz, System clock = 60 MHz, All peripherals disabled	—	13.9	—	mA
		V _{DD} = V _{DDA} = 3.3 V, HXTAL = 25 MHz, System clock = 30 MHz, All peripherals enabled	—	13.3	—	mA
		V _{DD} = V _{DDA} = 3.3 V, HXTAL = 25 MHz, System clock = 30 MHz, All peripherals disabled	—	9.5	—	mA
		V _{DD} = V _{DDA} = 3.3 V, HXTAL = 25 MHz, System clock = 25 MHz, All peripherals enabled	—	11.7	—	mA
		V _{DD} = V _{DDA} = 3.3 V, HXTAL = 25 MHz, System clock = 25 MHz, All peripherals disabled	—	8.5	—	mA
		V _{DD} = V _{DDA} = 3.3 V, HXTAL = 25 MHz, System clock = 16 MHz, All peripherals enabled	—	8.9	—	mA
		V _{DD} = V _{DDA} = 3.3 V, HXTAL = 25 MHz, System clock = 16 MHz, All peripherals disabled	—	6.9	—	mA
		V _{DD} = V _{DDA} = 3.3 V, HXTAL = 25 MHz, System clock = 8 MHz, All peripherals enabled	—	6.4	—	mA
		V _{DD} = V _{DDA} = 3.3 V, HXTAL = 25 MHz, System clock = 8 MHz, All peripherals disabled	—	5.3	—	mA
		V _{DD} = V _{DDA} = 3.3 V, HXTAL = 25 MHz, System clock = 4 MHz, All peripherals enabled	—	5.0	—	mA

Symbol	Parameter	Conditions	Min	Typ ⁽¹⁾	Max	Unit
		V _{DD} = V _{DDA} = 3.3 V, HXTAL = 25 MHz, System clock = 4 MHz, All peripherals disabled	—	4.5	—	mA
	Supply current (Sleep mode)	V _{DD} = V _{DDA} = 3.3 V, HXTAL = 25 MHz, System clock = 200 MHz, CPU clock off, All peripherals enabled	—	42.2	—	mA
		V _{DD} = V _{DDA} = 3.3 V, HXTAL = 25 MHz, System clock = 200 MHz, CPU clock off, All peripherals disabled	—	18.7	—	mA
		V _{DD} = V _{DDA} = 3.3 V, HXTAL = 25 MHz, System clock = 180 MHz, CPU clock off, All peripherals enabled	—	38.5	—	mA
		V _{DD} = V _{DDA} = 3.3 V, HXTAL = 25 MHz, System clock = 180 MHz, CPU clock off, All peripherals disabled	—	17.2	—	mA
		V _{DD} = V _{DDA} = 3.3 V, HXTAL = 25 MHz, System clock = 168 MHz, CPU clock off, All peripherals enabled	—	36.2	—	mA
		V _{DD} = V _{DDA} = 3.3 V, HXTAL = 25 MHz, System clock = 168 MHz, CPU clock off, All peripherals disabled	—	16.4	—	mA
		V _{DD} = V _{DDA} = 3.3 V, HXTAL = 25 MHz, System clock = 120 MHz, CPU clock off, All peripherals enabled	—	27.0	—	mA
		V _{DD} = V _{DDA} = 3.3 V, HXTAL = 25 MHz, System clock = 120 MHz, CPU clock off, All peripherals disabled	—	12.8	—	mA
		V _{DD} = V _{DDA} = 3.3 V, HXTAL = 25 MHz, System clock = 108 MHz, CPU clock off, All peripherals enabled	—	24.7	—	mA
		V _{DD} = V _{DDA} = 3.3 V, HXTAL = 25 MHz, System clock = 108 MHz, CPU clock off, All peripherals disabled	—	11.9	—	mA
		V _{DD} = V _{DDA} = 3.3 V, HXTAL = 25 MHz, System clock = 90 MHz, CPU clock off, All peripherals enabled	—	21.2	—	mA
		V _{DD} = V _{DDA} = 3.3 V, HXTAL = 25 MHz, System clock = 90 MHz, CPU clock off, All peripherals disabled	—	10.5	—	mA
		V _{DD} = V _{DDA} = 3.3 V, HXTAL = 25 MHz, System clock = 60 MHz, CPU clock off, All peripherals enabled	—	15.5	—	mA

Symbol	Parameter	Conditions	Min	Typ ⁽¹⁾	Max	Unit
		V _{DD} = V _{DDA} = 3.3 V, HXTAL = 25 MHz, System clock = 60 MHz, CPU clock off, All peripherals disabled	—	8.4	—	mA
		V _{DD} = V _{DDA} = 3.3 V, HXTAL = 25 MHz, System clock = 30 MHz, CPU clock off, All peripherals enabled	—	10.5	—	mA
		V _{DD} = V _{DDA} = 3.3 V, HXTAL = 25 MHz, System clock = 30 MHz, CPU clock off, All peripherals disabled	—	6.7	—	mA
		V _{DD} = V _{DDA} = 3.3 V, HXTAL = 25 MHz, System clock = 25 MHz, CPU clock off, All peripherals enabled	—	9.4	—	mA
		V _{DD} = V _{DDA} = 3.3 V, HXTAL = 25 MHz, System clock = 25 MHz, CPU clock off, All peripherals disabled	—	6.2	—	mA
		V _{DD} = V _{DDA} = 3.3 V, HXTAL = 25 MHz, System clock = 16 MHz, CPU clock off, All peripherals enabled	—	7.4	—	mA
		V _{DD} = V _{DDA} = 3.3 V, HXTAL = 25 MHz, System clock = 16 MHz, CPU clock off, All peripherals disabled	—	5.4	—	mA
		V _{DD} = V _{DDA} = 3.3 V, HXTAL = 25 MHz, System clock = 8 MHz, CPU clock off, All peripherals enabled	—	5.7	—	mA
		V _{DD} = V _{DDA} = 3.3 V, HXTAL = 25 MHz, System clock = 8 MHz, CPU clock off, All peripherals disabled	—	4.7	—	mA
		V _{DD} = V _{DDA} = 3.3 V, HXTAL = 25 MHz, System clock = 4 MHz, CPU clock off, All peripherals enabled	—	4.8	—	mA
		V _{DD} = V _{DDA} = 3.3 V, HXTAL = 25 MHz, System clock = 4 MHz, CPU clock off, All peripherals disabled	—	4.3	—	mA
	Supply current (Deep-Sleep mode)	V _{DD} = V _{DDA} = 3.3 V, LDO in run mode and normal driver mode, IRC32K off, RTC off	—	1.39	—	mA
		V _{DD} = V _{DDA} = 3.3 V, LDO in low power mode and normal driver mode, IRC32K off	—	1.36	11	mA
		V _{DD} = V _{DDA} = 3.3 V, LDO in run mode and low driver mode, IRC32K off, RTC off	—	1.33	—	mA
		V _{DD} = V _{DDA} = 3.3 V, LDO in low power mode and low driver mode, IRC32K off	—	1.30	—	mA
	Supply current (Standby mode)	V _{DD} = V _{DDA} = 3.3 V, LXTAL off, IRC32K on, RTC on, backup SRAM LDO ON	—	9.90	17.5	μA

Symbol	Parameter	Conditions	Min	Typ ⁽¹⁾	Max	Unit
		$V_{DD} = V_{DDA} = 3.3\text{ V}$, LXTAL off, IRC32K on, RTC off, backup SRAM LDO ON	—	9.67	17.3	μA
		$V_{DD} = V_{DDA} = 3.3\text{ V}$, LXTAL off, IRC32K off, RTC off, backup SRAM LDO ON	—	9.19	16.8	μA
		$V_{DD} = V_{DDA} = 3.3\text{ V}$, LXTAL off, IRC32K off, RTC off, backup SRAM LDO OFF	—	3.37 9	11	μA
I_{BAT}	Battery supply current (Backup mode)	V_{DD} off, V_{DDA} off, $V_{BAT}=3.6\text{V}$, LXTAL on with external crystal, RTC on, LXTAL High driving, backup SRAM LDO ON	—	9.09	—	μA
		V_{DD} off, V_{DDA} off, $V_{BAT}=3.3\text{V}$, LXTAL on with external crystal, RTC on, LXTAL High driving, backup SRAM LDO ON	—	8.93	—	μA
		V_{DD} off, V_{DDA} off, $V_{BAT}=2.6\text{V}$, LXTAL on with external crystal, RTC on, LXTAL High driving, backup SRAM LDO ON	—	8.74	—	μA
		V_{DD} off, V_{DDA} off, $V_{BAT}=1.8\text{V}$, LXTAL on with external crystal, RTC on, LXTAL High driving, backup SRAM LDO ON	—	7.47	—	μA
		V_{DD} off, V_{DDA} off, $V_{BAT}=3.6\text{V}$, LXTAL on with external crystal, RTC on, LXTAL High driving, backup SRAM LDO OFF	—	2.23	—	μA
		V_{DD} off, V_{DDA} off, $V_{BAT}=3.3\text{V}$, LXTAL on with external crystal, RTC on, LXTAL High driving, backup SRAM LDO OFF	—	2.13	—	μA
		V_{DD} off, V_{DDA} off, $V_{BAT}=2.6\text{V}$, LXTAL on with external crystal, RTC on, LXTAL High driving, backup SRAM LDO OFF	—	2	—	μA
		V_{DD} off, V_{DDA} off, $V_{BAT}=1.8\text{V}$, LXTAL on with external crystal, RTC on, LXTAL High driving, backup SRAM LDO OFF	—	1.89	—	μA
		V_{DD} off, V_{DDA} off, $V_{BAT}=3.6\text{V}$, LXTAL on with external crystal, RTC on, LXTAL Low driving, backup SRAM LDO ON	—	8.16	—	μA
		V_{DD} off, V_{DDA} off, $V_{BAT}=3.3\text{V}$, LXTAL on with external crystal, RTC on, LXTAL Low driving, backup SRAM LDO ON	—	8	—	μA
		V_{DD} off, V_{DDA} off, $V_{BAT}=2.6\text{V}$, LXTAL on with external crystal, RTC on, LXTAL Low driving, backup SRAM LDO ON	—	7.8	—	μA
		V_{DD} off, V_{DDA} off, $V_{BAT}=1.8\text{V}$, LXTAL on with external crystal, RTC on, LXTAL Low driving, backup SRAM LDO ON	—	6.7	—	μA

Symbol	Parameter	Conditions	Min	Typ ⁽¹⁾	Max	Unit
		V _{DD} off, V _{DDA} off, V _{BAT} =3.6V, LXTAL on with external crystal, RTC on, LXTAL Low driving, backup SRAM LDO OFF	—	1.27	—	μA
		V _{DD} off, V _{DDA} off, V _{BAT} =3.3V, LXTAL on with external crystal, RTC on, LXTAL Low driving, backup SRAM LDO OFF	—	1.18	—	μA
		V _{DD} off, V _{DDA} off, V _{BAT} =2.6V, LXTAL on with external crystal, RTC on, LXTAL Low driving, backup SRAM LDO OFF	—	1.06	—	μA
		V _{DD} off, V _{DDA} off, V _{BAT} =1.8V, LXTAL on with external crystal, RTC on, LXTAL Low driving, backup SRAM LDO OFF	—	0.96	—	μA

- (1) Based on characterization, not tested in production.
- (2) Unless otherwise specified, all values given for T_A = 25 °C and test result is mean value.
- (3) When System Clock is less than 4 MHz, an external source is used, and the HXTAL bypass function is needed, no PLL.
- (4) When System Clock is greater than 8 MHz, a crystal 8 MHz is used, and the HXTAL bypass function is closed, using PLL.
- (5) When analog peripheral blocks such as ADCs, DACs, HXTAL, LXTAL, IRC16M, or IRC32K are ON, an additional power consumption should be considered.
- (6) All GPIOs are configured as analog mode except standby mode.

Figure 4-2. Typical supply current consumption in Run mode

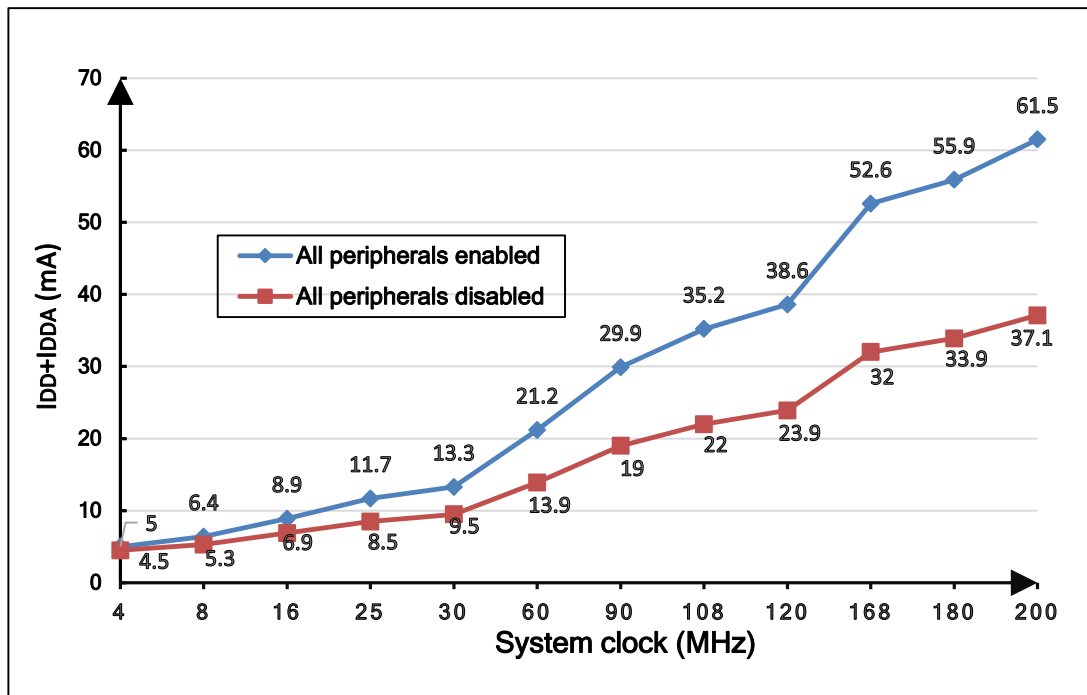
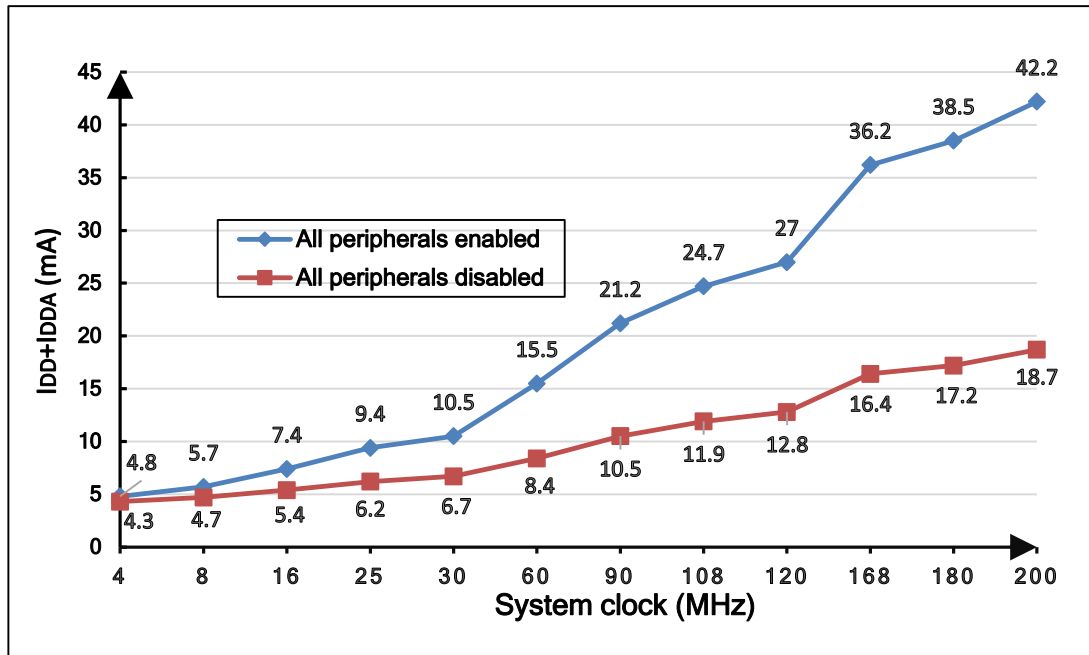

Figure 4-3. Typical supply current consumption in Sleep mode



4.4. EMC characteristics

EMS (electromagnetic susceptibility) includes ESD (Electrostatic discharge, positive and negative) and FTB (Burst of Fast Transient voltage, positive and negative) testing result is given in [Table 4-8. EMS characteristics](#), based on the EMS levels and classes compliant with IEC 61000 series standard.

Table 4-8. EMS characteristics⁽¹⁾

Symbol	Parameter	Conditions	Level/Class
V_{ESD}	Voltage applied to all device pins to induce a functional disturbance	$V_{DD} = 3.3\text{ V}$, $T_A = 25\text{ }^\circ\text{C}$ LQFP144, $f_{HCLK} = 200\text{ MHz}$ conforms to IEC 61000-4-2	3A
V_{FTB}	Fast transient voltage burst applied to induce a functional disturbance through 100 pF on VDD and VSS pins	$V_{DD} = 3.3\text{ V}$, $T_A = 25\text{ }^\circ\text{C}$ LQFP144, $f_{HCLK} = 200\text{ MHz}$ conforms to IEC 61000-4-4	3A

(1) Based on characterization, not tested in production.

EMI (Electromagnetic Interference) emission test result is given in the [Table 4-9. EMI characteristics](#)⁽¹⁾, The electromagnetic field emitted by the device are monitored while an application, executing EEMBC code, is running. The test is compliant with SAE J1752-3:2017 standard which specifies the test board and the pin loading.

Table 4-9. EMI characteristics⁽¹⁾

Symbol	Parameter	Conditions	Tested frequency band	Max vs.	Unit
				[f _{HXTAL} /f _{HCLK}]	
				25/200 MHz	
S _{EMI}	Peak level	V _{DD} = 3.6 V, T _A = +25 °C, LQFP144, f _{HCLK} = 200 MHz, conforms to SAE J1752-3:2017	0.15 MHz to 30 MHz	3.60	dBμV
			30 MHz to 130 MHz	12.09	
			130 MHz to 1 GHz	8.59	

(1) Based on characterization, not tested in production.

4.5. Power supply supervisor characteristics

Table 4-10. Power supply supervisor characteristics

Symbol	Parameter	Conditions	Min	Typ	Max	Unit
V _{LVD} ⁽¹⁾	Low voltage Detector level selection	LVDT<2:0> = 000(rising edge)	—	2.1	—	V
		LVDT<2:0> = 000(falling edge)	—	1.98	—	
		LVDT<2:0> = 001(rising edge)	—	2.23	—	
		LVDT<2:0> = 001(falling edge)	—	2.12	—	
		LVDT<2:0> = 010(rising edge)	—	2.36	—	
		LVDT<2:0> = 010(falling edge)	—	2.25	—	
		LVDT<2:0> = 011(rising edge)	—	2.50	—	
		LVDT<2:0> = 011(falling edge)	—	2.38	—	
		LVDT<2:0> = 100(rising edge)	—	2.62	—	
		LVDT<2:0> = 100(falling edge)	—	2.52	—	
		LVDT<2:0> = 101(rising edge)	—	2.74	—	
		LVDT<2:0> = 101(falling edge)	—	2.66	—	
		LVDT<2:0> = 110(rising edge)	—	2.90	—	
		LVDT<2:0> = 110(falling edge)	—	2.80	—	
LVDT<2:0> = 111(rising edge)	—	3.03	—			
LVDT<2:0> = 111(falling edge)	—	2.93	—			
V _{LVDhyst} ⁽²⁾	LVD hysteresis	—	—	100	—	mV
V _{POR} ⁽¹⁾	Power on reset threshold	—	—	2.45	—	V
V _{PDR} ⁽¹⁾	Power down reset threshold	—	—	1.82	—	V

Symbol	Parameter	Conditions	Min	Typ	Max	Unit
$V_{PDRhyst}^{(2)}$	PDR hysteresis	—	—	600	—	mV
$V_{BOR3}^{(1)}$	Brownout level 3 threshold	Falling edge	—	2.80	—	V
		Rising edge	—	2.89	—	V
$V_{BOR2}^{(1)}$	Brownout level 2 threshold	Falling edge	—	2.51	—	V
		Rising edge	—	2.59	—	V
$V_{BOR1}^{(1)}$	Brownout level 1 threshold	Falling edge	—	2.20	—	V
		Rising edge	—	2.30	—	V
$V_{BORhyst}^{(2)}$	BOR hysteresis	—	—	100	—	mV
$t_{RSTTEMPO}^{(2)}$	Reset temporization	—	—	2	—	ms

- (1) Based on characterization, not tested in production.
 (2) Guaranteed by design, not tested in production.

Figure 4-4. Recommended PDR_ON pin circuit

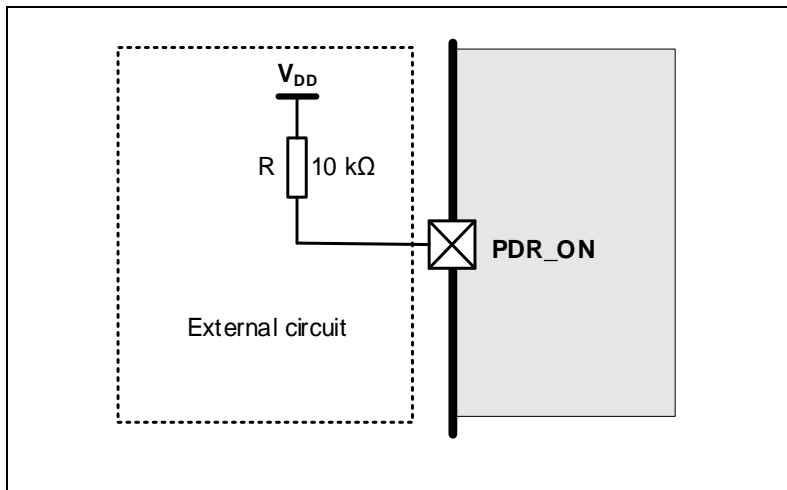

- The PDR supervisor can be enabled/disabled through PDR_ON pin.
- When PDR_ON pin is connected to VSS (Internal Reset OFF), the VBAT functionality is no more available and VBAT pin should be connected to VDD.
- The PDR_ON pin must be kept at high level. The user can flexibly adjust the value of the pull-up resistor R according to the specific scenario for a better performance.

4.6. Electrical sensitivity

The device is strained in order to determine its performance in terms of electrical sensitivity. Electrostatic discharges (ESD) are applied directly to the pins of the sample. Static latch-up (LU) test is based on the two measurement methods.

Table 4-11. ESD characteristics⁽¹⁾

Symbol	Parameter	Conditions	Min	Typ	Max	Unit
$V_{ESD(HBM)}$	Electrostatic discharge voltage (human body model)	$T_A=25\text{ }^\circ\text{C}$; JS-001-2017	—	—	5000	V

Symbol	Parameter	Conditions	Min	Typ	Max	Unit
$V_{ESD(CDM)}$	Electrostatic discharge voltage (charge device model)	$T_A=25\text{ }^\circ\text{C}$; JS-002-2018	—	—	1000	V

(1) Based on characterization, not tested in production.

Table 4-12. Static latch-up characteristics⁽¹⁾

Symbol	Parameter	Conditions	Min	Typ	Max	Unit
LU	I-test	$T_A=105\text{ }^\circ\text{C}$; JESD78	—	—	±200	mA
	V_{supply} over voltage		—	—	5.4	V

(1) Based on characterization, not tested in production.

4.7. External clock characteristics

Table 4-13. High speed external clock (HXTAL) generated from a crystal/ceramic characteristics

Symbol	Parameter	Conditions	Min	Typ	Max	Unit
$f_{HXTAL}^{(1)}$	Crystal or ceramic frequency	$2.6\text{ V} \leq V_{DD} \leq 3.6\text{ V}$	4	25	32	MHz
$R_F^{(2)}$	Feedback resistor	$V_{DD} = 3.3\text{ V}$	—	400	—	kΩ
$C_{HXTAL}^{(2)(3)}$	Recommended matching capacitance on OSCIN and OSCOUT	—	—	20	30	pF
$D_{ucy(HXTAL)}^{(2)}$	Crystal or ceramic duty cycle	—	30	50	70	%
$g_m^{(2)}$	Oscillator transconductance	Startup	—	25	—	mA/V
$I_{DDHXTAL}^{(1)}$	Crystal or ceramic operating current	$V_{DD} = 3.3\text{ V}$	—	1.2	—	mA
$t_{SUHXTAL}^{(1)}$	Crystal or ceramic startup time	$V_{DD} = 3.3\text{ V}$	—	0.42	—	ms

(1) Based on characterization, not tested in production.

(2) Guaranteed by design, not tested in production.

(3) $C_{HXTAL1} = C_{HXTAL2} = 2 * (C_{LOAD} - C_S)$, For C_{HXTAL1} and C_{HXTAL2} , it is recommended matching capacitance on OSCIN and OSCOUT. For C_{LOAD} , it is crystal/ceramic load capacitance, provided by the crystal or ceramic manufacturer. For C_S , it is PCB and MCU pin stray capacitance.

Table 4-14. High speed external clock characteristics (HXTAL in bypass mode)

Symbol	Parameter	Conditions	Min	Typ	Max	Unit
$f_{HXTAL_ext}^{(1)}$	External clock source or oscillator frequency	$2.6\text{ V} \leq V_{DD} \leq 3.6\text{ V}$	1	—	50	MHz
$V_{HXTALH}^{(2)}$	OSCIN input pin high level voltage	$V_{DD} = 3.3\text{ V}$	$0.7 V_{DD}$	—	V_{DD}	V
$V_{HXTALL}^{(2)}$	OSCIN input pin low level voltage		V_{SS}	—	$0.3 V_{DD}$	V
$t_{H/L(HXTAL)}^{(2)}$	OSCIN high or low time	—	5	—	—	ns
$t_{R/F(HXTAL)}^{(2)}$	OSCIN rise or fall time	—	—	—	10	ns
$C_{IN}^{(2)}$	OSCIN input capacitance	—	—	5	—	pF
$D_{ucy(HXTAL)}^{(2)}$	Duty cycle	—	40	—	60	%

- (1) Based on characterization, not tested in production.
 (2) Guaranteed by design, not tested in production.

Table 4-15. Low speed external clock (LXTAL) generated from a crystal/ceramic characteristics

Symbol	Parameter	Conditions	Min	Typ	Max	Unit
$f_{LXTAL}^{(1)}$	Crystal or ceramic frequency	$V_{DD} = 3.3 V$	—	32.768	—	kHz
$C_{LXTAL}^{(2)(3)}$	Recommended matching capacitance on OSC32IN and OSC32OUT	—	—	15	—	pF
$Ducy_{(LXTAL)}^{(2)}$	Crystal or ceramic duty cycle	—	30	—	70	%
$g_m^{(2)}$	Oscillator transconductance	Medium low driving capability	—	6	—	$\mu A/V$
		Higher driving capability	—	18	—	
$I_{DDLXTAL}^{(1)}$	Crystal or ceramic operating current	LXTALDRI= 0	—	0.8	—	μA
		LXTALDRI= 1	—	1.6	—	
$t_{SULXTAL}^{(1)(4)}$	Crystal or ceramic startup time	LXTALDRI= 0	—	369	—	ms
		LXTALDRI= 1	—	175	—	ms

- (1) Based on characterization, not tested in production.
 (2) Guaranteed by design, not tested in production.
 (3) $C_{LXTAL1} = C_{LXTAL2} = 2 * (C_{LOAD} - C_S)$, For C_{LXTAL1} and C_{LXTAL2} , it is recommended matching capacitance on OSC32IN and OSC32OUT. For C_{LOAD} , it is crystal/ceramic load capacitance, provided by the crystal or ceramic manufacturer. For C_S , it is PCB and MCU pin stray capacitance.
 (4) $t_{SULXTAL}$ is the startup time measured from the moment it is enabled (by software) to the 32.768 kHz oscillator stabilization flags is SET. This value varies significantly with the crystal manufacturer.

Table 4-16. Low speed external user clock characteristics (LXTAL in bypass mode)

Symbol	Parameter	Conditions	Min	Typ	Max	Unit
$f_{LXTAL_ext}^{(1)}$	External clock source or oscillator frequency	$V_{DD} = 3.3 V$	—	32.768	1000	kHz
$V_{LXTALH}^{(2)}$	OSC32IN input pin high level voltage	—	$0.7 V_{DD}$	—	V_{DD}	V
$V_{LXTALL}^{(2)}$	OSC32IN input pin low level voltage	—	V_{SS}	—	$0.3 V_{DD}$	
$t_{H/L(LXTAL)}^{(2)}$	OSC32IN high or low time	—	450	—	—	ns
$t_{R/F(LXTAL)}^{(2)}$	OSC32IN rise or fall time	—	—	—	50	
$C_{IN}^{(2)}$	OSC32IN input capacitance	—	—	5	—	pF
$Ducy_{(LXTAL)}^{(2)}$	Duty cycle	—	30	50	70	%

- (1) Based on characterization, not tested in production.
 (2) Guaranteed by design, not tested in production.

4.8. Internal clock characteristics

Table 4-17. High speed internal clock (IRC16M) characteristics

Symbol	Parameter	Conditions	Min	Typ	Max	Unit
f_{IRC16M}	High Speed Internal Oscillator (IRC16M) frequency	$V_{DD} = V_{DDA} = 3.3\text{ V}$	—	16	—	MHz
ACC_{IRC16M}	IRC16M oscillator Frequency accuracy, Factory-trimmed	$V_{DD} = V_{DDA} = 3.3\text{ V}$, $T_A = -40\text{ }^{\circ}\text{C} \sim +85\text{ }^{\circ}\text{C}^{(1)}$	—	-1.73 to +1.1 ⁽¹⁾	—	%
		$V_{DD} = V_{DDA} = 3.3\text{ V}$, $T_A = 25\text{ }^{\circ}\text{C}$	-1.0	—	+1.0	%
	IRC16M oscillator Frequency accuracy, User trimming step	—	—	0.5	—	%
$Ducy_{IRC16M}^{(2)}$	IRC16M oscillator duty cycle	$V_{DD} = V_{DDA} = 3.3\text{ V}$	45	50	55	%
$I_{DDIRC16M}$ $+I_{DDAIRC16M}^{(1)}$	IRC16M oscillator operating current	$V_{DD} = V_{DDA} = 3.3\text{ V}$, $f_{HCLK} = f_{HXTAL} = 25\text{ MHz}$	—	47	—	μA
$t_{SUIRC16M}^{(1)}$	IRC16M oscillator startup time	$V_{DD} = V_{DDA} = 3.3\text{ V}$, $f_{HCLK} = f_{HXTAL_PLL} = 200\text{ MHz}$	—	1.18	—	μs

(1) Based on characterization, not tested in production.

(2) Guaranteed by design, not tested in production.

Table 4-18. High speed internal clock (IRC48M) characteristics

Symbol	Parameter	Conditions	Min	Typ	Max	Unit
f_{IRC48M}	High Speed Internal Oscillator (IRC48M) frequency	$V_{DD} = 3.3\text{ V}$	—	48	—	MHz
ACC_{IRC48M}	IRC48M oscillator Frequency accuracy, Factory-trimmed	$V_{DD} = V_{DDA} = 3.3\text{ V}$, $T_A = -40\text{ }^{\circ}\text{C} \sim +85\text{ }^{\circ}\text{C}^{(1)}$	—	-1.31 to +0.39 ⁽¹⁾	—	%
		$V_{DD} = V_{DDA} = 3.3\text{ V}$, $T_A = 25\text{ }^{\circ}\text{C}$	-2.0	—	+2.0	%
	IRC48M oscillator Frequency accuracy, User trimming step	—	—	0.12	—	%
$Ducy_{IRC48M}^{(2)}$	IRC48M oscillator duty cycle	$V_{DD} = V_{DDA} = 3.3\text{ V}$	45	50	55	%
$I_{DDIRC48M}$ $+I_{DDAIRC48M}^{(1)}$	IRC48M oscillator operating current	$V_{DD} = V_{DDA} = 3.3\text{ V}$, $f_{HCLK} = f_{IRC16M} = 16\text{ MHz}$	—	358	—	μA
$t_{SUIRC48M}^{(1)}$	IRC48M oscillator startup time	$V_{DD} = V_{DDA} = 3.3\text{ V}$, $f_{HCLK} = f_{HXTAL_PLL} = 200\text{ MHz}$	—	1.23	—	μs

(1) Based on characterization, not tested in production.

(2) Guaranteed by design, not tested in production.

Table 4-19. Low speed internal clock (IRC32K) characteristics

Symbol	Parameter	Conditions	Min	Typ	Max	Unit
$f_{IRC32K}^{(1)}$	Low Speed Internal oscillator (IRC32K) frequency	$V_{DD} = V_{DDA} = 3.3\text{ V}$, $T_A = -40\text{ }^{\circ}\text{C} \sim +85\text{ }^{\circ}\text{C}$	—	32	—	kHz
$I_{DDAIRC32K}^{(2)}$	IRC32K oscillator operating current	$V_{DD} = V_{DDA} = 3.3\text{ V}$, $f_{HCLK} = f_{IRC16M} = 16\text{ MHz}$,	—	0.43	—	μA
$t_{SUIRC32K}^{(2)}$	IRC32K oscillator startup time	$V_{DD} = V_{DDA} = 3.3\text{ V}$, $f_{HCLK} =$ $f_{HXTAL_PLL} = 200\text{ MHz}$,	—	22.1	—	μs

(1) Guaranteed by design, not tested in production.

(2) Based on characterization, not tested in production.

4.9. PLL characteristics

Table 4-20. PLL characteristics

Symbol	Parameter	Conditions	Min	Typ	Max	Unit
$f_{PLLIN}^{(1)}$	PLL input clock frequency	—	1	—	4	MHz
$f_{PLLOUT}^{(2)}$	PLL output clock frequency	—	32	—	250	MHz
$f_{VCO}^{(2)}$	PLL VCO output clock frequency	—	64	—	500	MHz
$t_{LOCK}^{(2)}$	PLL lock time	—	—	—	400	μs
$I_{DDA}^{(1)(3)}$	Current consumption on V_{DDA}	VCO freq = 400 MHz	—	797	—	μA
Jitter _{PLL}	Cycle to cycle Jitter(rms)	System clock	—	40	—	ps
	Cycle to cycle Jitter (peak to peak)		—	400	—	

(1) Based on characterization, not tested in production.

(2) Guaranteed by design, not tested in production.

(3) System clock = HXTAL = 25 MHz, PLL clock source = HXTAL/25 = 1 MHz, $f_{PLLOUT} = 100\text{ MHz}$.

(4) Value given with main PLL running.

Table 4-21. PLLI2S characteristics

Symbol	Parameter	Conditions	Min	Typ	Max	Unit
$f_{PLLIN}^{(1)}$	PLLI2S input clock frequency	—	1	—	4	MHz
$f_{PLLOUT}^{(2)}$	PLLI2S output clock frequency	—	32	—	250	MHz
$f_{VCO}^{(2)}$	PLLI2S VCO output clock frequency	—	64	—	500	MHz
$t_{LOCK}^{(2)}$	PLLI2S lock time	—	—	—	400	μs
$I_{DDA}^{(1)(3)}$	Current consumption on V_{DDA}	VCO freq = 400 MHz	—	814	—	μA
Jitter _{PLL}	Cycle to cycle Jitter(rms)	System clock	—	40	—	ps
	Cycle to cycle Jitter (peak to peak)		—	400	—	

- (1) Based on characterization, not tested in production.
- (2) Guaranteed by design, not tested in production.
- (3) System clock = HXTAL = 25 MHz, PLL clock source = HXTAL/25 = 1 MHz, $f_{\text{PPLLOUT}} = 100$ MHz.
- (4) Value given with main PLLI2S running.

Table 4-22. PLLSAI characteristics

Symbol	Parameter	Conditions	Min	Typ	Max	Unit
$f_{\text{PLLIN}}^{(1)}$	PLLSAI input clock frequency	—	1	—	4	MHz
$f_{\text{PPLLOUT}}^{(2)}$	PLLSAI output clock frequency	—	32	—	250	MHz
$f_{\text{VCO}}^{(2)}$	PLLSAI VCO output clock frequency	—	64	—	500	MHz
$t_{\text{LOCK}}^{(2)}$	PLLSAI lock time	—	—	—	400	μs
$I_{\text{DDA}}^{(1)(3)}$	Current consumption on V_{DDA}	VCO freq = 400 MHz	—	796	—	μA
Jitter _{PLL}	Cycle to cycle Jitter(rms)	System clock	—	40	—	ps
	Cycle to cycle Jitter (peak to peak)		—	400	—	

- (1) Based on characterization, not tested in production.
- (2) Guaranteed by design, not tested in production.
- (3) System clock = HXTAL = 25 MHz, PLL clock source = HXTAL/25 = 1 MHz, $f_{\text{PPLLOUT}} = 100$ MHz.
- (4) Value given with main PLLSAI running.

Table 4-23. PLL spread spectrum clock generation (SSCG) characteristics

Symbol	Parameter	Conditions	Min	Typ	Max	Unit
f_{mod}	Modulation frequency	—	—	—	10	KHz
mdamp	Peak modulation amplitude	—	—	—	2	%
MODCNT* MODSTEP	—	—	—	—	$2^{15}-1$	—

- (1) Based on characterization, not tested in production.
- (2) Guaranteed by design, not tested in production.

Equation 1: SSCG configuration equation:

$$\text{MODCNT} = \text{round}(f_{\text{PLLIN}}/4/f_{\text{mod}})$$

$$\text{MODSTEP} = \text{round}(\text{mdamp} * \text{PLL} * 2^{14}/(\text{MODCNT} * 100))$$

The formula above (Equation 1) is SSCG configuration equation.

4.10. Memory characteristics

Table 4-24. Flash memory characteristics⁽¹⁾

Symbol	Parameter	Conditions	Min	Typ	Max	Unit
PE _{CYC}	Number of guaranteed program /erase cycles before failure (Endurance)	T _A = -40 °C ~ +85 °C	100	—	—	kcycles
t _{READ}	Read time at code flash area	T _A = -40 °C ~ +85 °C	—	1	—	hclks
	Read time at data flash area		56	—	4176	
t _{RET}	Data retention time	—	—	20	—	years
t _{PROG}	Word programming time	T _A = -40°C ~ +85 °C	—	37.5	180	μs
t _{ERASE16kB}	Sector(16kB) erase time	T _A = -40°C ~ +85 °C	—	200	2000	ms
t _{ERASE64kB}	Sector(64kB) erase time		—	300	4000	
t _{ERASE128kB}	Sector(128kB) erase time		—	600	8000	
t _{MERASE(512K)}	Mass erase time	T _A = -40°C ~ +85 °C	—	2.4	32	s
t _{MERASE(1MB)}	Mass erase time	T _A = -40°C ~ +85 °C	—	4.8	64	s
t _{MERASE(2MB)}	Mass erase time	T _A = -40°C ~ +85 °C	—	9.6	128	s
t _{MERASE(3MB)}	Mass erase time	T _A = -40°C ~ +85 °C	—	14.4	192	s

(1) Guaranteed by design and/or characterization, not 100% tested in production.

NRST pin characteristics

Table 4-25. NRST pin characteristics

Symbol	Parameter	Conditions	Min	Typ	Max	Unit
V _{IL(NRST)} ⁽¹⁾	NRST Input low level voltage	V _{DD} = V _{DDA} = 2.6 V	-0.3	—	0.3 V _{DD}	V
V _{IH(NRST)} ⁽¹⁾	NRST Input high level voltage		0.7 V _{DD}	—	V _{DD} + 0.3	
V _{hyst} ⁽¹⁾	Schmidt trigger Voltage hysteresis		—	440	—	
V _{IL(NRST)} ⁽¹⁾	NRST Input low level voltage	V _{DD} = V _{DDA} = 3.3 V	-0.3	—	0.3 V _{DD}	V
V _{IH(NRST)} ⁽¹⁾	NRST Input high level voltage		0.7 V _{DD}	—	V _{DD} + 0.3	
V _{hyst} ⁽¹⁾	Schmidt trigger Voltage hysteresis		—	490	—	
V _{IL(NRST)} ⁽¹⁾	NRST Input low level voltage	V _{DD} = V _{DDA} = 3.6 V	-0.3	—	0.3 V _{DD}	V
V _{IH(NRST)} ⁽¹⁾	NRST Input high level voltage		0.7 V _{DD}	—	V _{DD} + 0.3	
V _{hyst} ⁽¹⁾	Schmidt trigger Voltage hysteresis		—	510	—	
R _{pu} ⁽²⁾	Pull-up equivalent resistor	—	—	40	—	kΩ

(1) Based on characterization, not tested in production.

(2) Guaranteed by design, not tested in production.

Figure 4-5. Recommended external NRST pin circuit⁽¹⁾

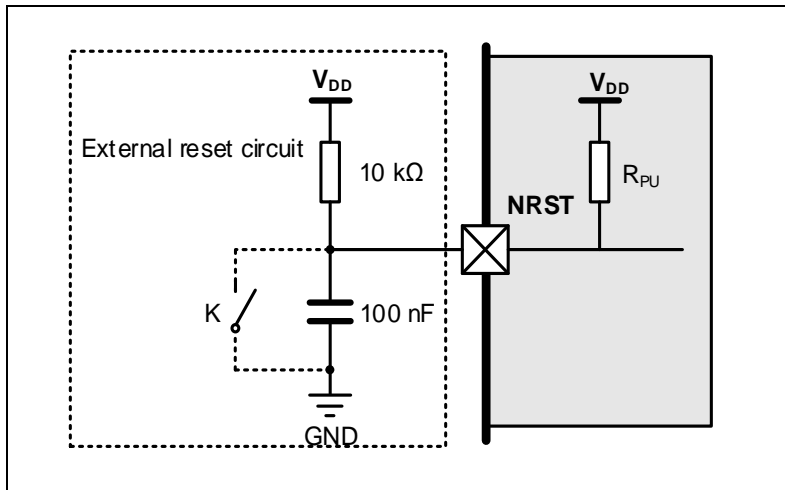

(1) Unless the voltage on NRST pin go below $V_{IL(NRST)}$ level, the device would not generate a reliable reset.

4.11. GPIO characteristics

Table 4-26. I/O port DC characteristics⁽¹⁾⁽³⁾

Symbol	Parameter	Conditions	Min	Typ	Max	Unit	
V_{IL}	Standard IO Low level input voltage	$2.6\text{ V} \leq V_{DD} = V_{DDA} \leq 3.6\text{ V}$	—	—	$0.3 V_{DD}$	V	
	5V-tolerant IO Low level input voltage	$2.6\text{ V} \leq V_{DD} = V_{DDA} \leq 3.6\text{ V}$	—	—	$0.3 V_{DD}$	V	
V_{IH}	Standard IO High level input voltage	$2.6\text{ V} \leq V_{DD} = V_{DDA} \leq 3.6\text{ V}$	$0.7 V_{DD}$	—	—	V	
	5V-tolerant IO High level input voltage	$2.6\text{ V} \leq V_{DD} = V_{DDA} \leq 3.6\text{ V}$	$0.7 V_{DD}$	—	—	V	
$R_{PU}^{(2)}$	Internal pull-up resistor	All pins	$V_{IN} = V_{SS}$	—	40	—	kΩ
		PA10	—	—	10	—	
$R_{PD}^{(2)}$	Internal pull-down resistor	All pins	$V_{IN} = V_{DD}$	—	40	—	kΩ
		PA10	—	—	10	—	
IO_Speed:level 3							
V_{OL}	Low level output voltage for an IO Pin ($I_{IO} = +8\text{ mA}$)	$V_{DD} = 2.6\text{ V}$	—	—	0.2	V	
		$V_{DD} = 3.3\text{ V}$	—	—	0.2		
		$V_{DD} = 3.6\text{ V}$	—	—	0.2		
	Low level output voltage for an IO Pin ($I_{IO} = +20\text{ mA}$)	$V_{DD} = 2.6\text{ V}$	—	—	0.29		
		$V_{DD} = 3.3\text{ V}$	—	—	0.27		
		$V_{DD} = 3.6\text{ V}$	—	—	0.26		
V_{OH}	High level output voltage for an IO Pin ($I_{IO} = +8\text{ mA}$)	$V_{DD} = 2.6\text{ V}$	2.38	—	—		
		$V_{DD} = 3.3\text{ V}$	3.1	—	—		
		$V_{DD} = 3.6\text{ V}$	3.4	—	—		
	High level output voltage for an IO Pin	$V_{DD} = 2.6\text{ V}$	2.22	—	—		
		$V_{DD} = 3.3\text{ V}$	2.98	—	—		

Symbol	Parameter	Conditions	Min	Typ	Max	Unit
	(I _{IO} = +20 mA)	V _{DD} = 3.6 V	3.29	—	—	
IO_Speed:level 2						
V _{OL}	Low level output voltage for an IO Pin (I _{IO} = +8 mA)	V _{DD} = 2.6 V	—	—	0.25	V
		V _{DD} = 3.3 V	—	—	0.24	
		V _{DD} = 3.6 V	—	—	0.24	
	Low level output voltage for an IO Pin (I _{IO} = +20 mA)	V _{DD} = 2.6 V	—	—	0.43	
		V _{DD} = 3.3 V	—	—	0.37	
		V _{DD} = 3.6 V	—	—	0.36	
V _{OH}	High level output voltage for an IO Pin (I _{IO} = +8 mA)	V _{DD} = 2.6 V	2.32	—	—	
		V _{DD} = 3.3 V	3.04	—	—	
		V _{DD} = 3.6 V	3.36	—	—	
	High level output voltage for an IO Pin (I _{IO} = +20 mA)	V _{DD} = 2.6 V	2.05	—	—	
		V _{DD} = 3.3 V	2.84	—	—	
		V _{DD} = 3.6 V	3.17	—	—	
IO_Speed:level 1						
V _{OL}	Low level output voltage for an IO Pin (I _{IO} = +8 mA)	V _{DD} = 2.6 V	—	—	0.37	V
		V _{DD} = 3.3 V	—	—	0.38	
		V _{DD} = 3.6 V	—	—	0.34	
	Low level output voltage for an IO Pin (I _{IO} = +20 mA)	(I _{IO} = +15 mA), V _{DD} = 2.6 V	—	—	0.57	
		V _{DD} = 3.3 V	—	—	0.66	
		V _{DD} = 3.6 V	—	—	0.64	
V _{OH}	High level output voltage for an IO Pin (I _{IO} = +8 mA)	V _{DD} = 2.6 V	2.15	—	—	
		V _{DD} = 3.3 V	2.92	—	—	
		V _{DD} = 3.6 V	3.23	—	—	
	High level output voltage for an IO Pin (I _{IO} = +20 mA)	(I _{IO} = +15 mA), V _{DD} = 2.6 V	1.83	—	—	
		V _{DD} = 3.3 V	2.45	—	—	
		V _{DD} = 3.6 V	2.81	—	—	
IO_Speed:level 0						
V _{OL}	Low level output voltage for an IO Pin (I _{IO} = +1 mA)	V _{DD} = 2.6 V	—	—	0.17	V
		V _{DD} = 3.3 V	—	—	0.15	
		V _{DD} = 3.6 V	—	—	0.15	
	Low level output voltage for an IO Pin (I _{IO} = +4 mA)	V _{DD} = 2.6 V	—	—	0.80	
		V _{DD} = 3.3 V	—	—	0.63	
		V _{DD} = 3.6 V	—	—	0.60	
V _{OH}	High level output voltage for an IO Pin (I _{IO} = +1 mA)	V _{DD} = 2.6 V	2.38	—	—	
		V _{DD} = 3.3 V	3.12	—	—	
		V _{DD} = 3.6 V	3.42	—	—	
	High level output voltage for an IO Pin	V _{DD} = 2.6 V	1.45	—	—	
		V _{DD} = 3.3 V	2.48	—	—	
		V _{DD} = 3.6 V	3.42	—	—	

Symbol	Parameter	Conditions	Min	Typ	Max	Unit
	(I _{IO} = +4 mA)	V _{DD} = 3.6 V	2.83	—	—	

- (1) Based on characterization, not tested in production.
- (2) Guaranteed by design, not tested in production.
- (3) All pins except PC13 / PC14 / PC15 / PI8. Since PC13 to PC15 and PI8 are supplied through the Power Switch, which can only be obtained by a small current(typical source capability:3mA shared between these IOs, but sink capability is same as other IO) , the speed of GPIOs PC13 to PC15 and PI8 should not exceed 2 MHz when they are in output mode(maximum load: 30 pF).

Table 4-27. I/O port AC characteristics⁽¹⁾⁽²⁾⁽⁴⁾

GPIOx_OSPD[1:0] bit value ⁽³⁾	Parameter	Conditions	Max	Unit
GPIOx_OSPD0->OSPDy[1:0] = 00 (IO_Speed:level 0)	T _{Rise} /T _{Fall}	2.6 ≤ V _{DD} ≤ 3.6 V, C _L = 10 pF	51	ns
		2.6 ≤ V _{DD} ≤ 3.6 V, C _L = 30 pF	63.2	
		2.6 ≤ V _{DD} ≤ 3.6 V, C _L = 50 pF	74.2	
GPIOx_OSPD0->OSPDy[1:0] = 01 (IO_Speed:level 1)	T _{Rise} /T _{Fall}	2.6 ≤ V _{DD} ≤ 3.6 V, C _L = 10 pF	3.6	ns
		2.6 ≤ V _{DD} ≤ 3.6 V, C _L = 30 pF	9.6	
		2.6 ≤ V _{DD} ≤ 3.6 V, C _L = 50 pF	12.2	
GPIOx_OSPD0->OSPDy[1:0] = 10 (IO_Speed: level 2)	T _{Rise} /T _{Fall}	2.6 ≤ V _{DD} ≤ 3.6 V, C _L = 10 pF	2.2	ns
		2.6 ≤ V _{DD} ≤ 3.6 V, C _L = 30 pF	3	
		2.6 ≤ V _{DD} ≤ 3.6 V, C _L = 50 pF	3.8	
GPIOx_OSPD0->OSPDy[1:0] = 11 (IO_Speed:level 3)	T _{Rise} /T _{Fall}	2.6 ≤ V _{DD} ≤ 3.6 V, C _L = 10 pF	2	ns
		2.6 ≤ V _{DD} ≤ 3.6 V, C _L = 30 pF	2.8	
		2.6 ≤ V _{DD} ≤ 3.6 V, C _L = 50 pF	3.4	

- (1) Based on characterization, not tested in production.
- (2) Unless otherwise specified, all test results given for T_A = 25 °C.
- (3) The I/O speed is configured using the GPIOx_OSPD -> OSPDy[1:0]bits.
- (4) Only for reference, Depending on user's design.
- (5) Max frequency is defined when the sum of rise time plus the fall time is less than 2/3 cycle.

4.12. ADC characteristics

Table 4-28. ADC characteristics

Symbol	Parameter	Conditions	Min	Typ	Max	Unit
V _{DDA} ⁽¹⁾	Operating voltage	—	2.6	3.3	3.6	V
V _{IN} ⁽¹⁾	ADC input voltage range	—	0	—	V _{REFP}	V
V _{REFP} ⁽²⁾⁽³⁾	Positive Reference Voltage	—	2.6	—	V _{DDA}	V
V _{REFN} ⁽²⁾	Negative Reference Voltage	—	—	V _{SSA}	—	V
f _{ADC} ⁽¹⁾	ADC clock	—	0.1	—	40	MHz
f _s ⁽¹⁾	Sampling rate	12-bit	0.007	—	2.6	MS
		10-bit	0.008	—	3.1	
		8-bit	0.01	—	3.6	PS
		6-bit	0.011	—	4.4	
V _{AIN} ⁽¹⁾	Analog input voltage	16 external;3 internal	0	—	V _{REFP}	V
R _{AIN} ⁽²⁾	External input impedance	See Equation 2	—	—	308.6	kΩ
R _{ADC} ⁽²⁾	Input sampling switch resistance	—	—	—	0.55	kΩ
C _{ADC} ⁽²⁾	Input sampling capacitance	No pin/pad capacitance included	—	—	4.0	pF
t _{CAL} ⁽²⁾	Calibration time	f _{ADC} = 40 MHz	—	3.275	—	μs
t _s ⁽²⁾	Sampling time	f _{ADC} = 40 MHz	0.075	—	12	μs
t _{CONV} ⁽²⁾	Total conversion time (including sampling time)	12-bit	—	15	—	1/ f _{ADC}
		10-bit	—	13	—	
		8-bit	—	11	—	
		6-bit	—	9	—	
t _{SU} ⁽²⁾	Startup time	—	—	—	1	μs

(1) Based on characterization, not tested in production.

(2) Guaranteed by design, not tested in production.

(3) V_{REFP} should always be equal to or less than V_{DDA}, especially during power up.

Equation 2: R_{AIN} max formula
$$R_{AIN} < \frac{T_s}{f_{ADC} \cdot C_{ADC} \cdot \ln(2^{N+2})} - R_{ADC}$$

The formula above (Equation 2) is used to determine the maximum external impedance allowed for an error below 1/4 of LSB. Here N = 12 (from 12-bit resolution).

Table 4-29. ADC RAIN max for f_{ADC} = 40 MHz⁽²⁾

T _s (cycles)	t _s (us)	R _{AIN} max (KΩ)
3	0.075	1.3
15	0.375	9.1
28	0.7	17.4
55	1.375	34.8
84	2.1	53.5
112	2.8	71.5
144	3.6	92.1

T_s (cycles)	t_s (us)	$R_{AIN\ max}$ (K Ω)
480	12	308.6

- (1) Based on characterization, not tested in production.
(2) Guaranteed by design, not tested in production.

Table 4-30. ADC dynamic accuracy at $f_{ADC} = 40$ MHz⁽¹⁾

Symbol	Parameter	Test conditions	Min	Typ	Max	Unit
ENOB	Effective number of bits	$f_{ADC} = 40$ MHz $V_{DDA} = V_{REFP} = 3.3$ V Input Frequency = 110 kHz Temperature = 25 °C	—	10.9	—	bits
SNDR	Signal-to-noise and distortion ratio		—	67.3	—	dB
SNR	Signal-to-noise ratio		—	67.7	—	
THD	Total harmonic distortion		—	-75	—	

- (1) Based on characterization, not tested in production.

Table 4-31. ADC static accuracy at $f_{ADC} = 40$ MHz⁽¹⁾

Symbol	Parameter	Test conditions	Typ	Max	Unit
Offset	Offset error	$f_{ADC} = 40$ MHz $V_{DDA} = V_{REFP} = 3.3$ V	± 1	—	LSB
DNL	Differential linearity error		± 1	—	
INL	Integral linearity error		± 1.5	—	

- (1) Based on characterization, not tested in production.

4.13. Temperature sensor characteristics

Table 4-32. Temperature sensor characteristics⁽¹⁾

Symbol	Parameter	Min	Typ	Max	Unit
T_L	VSENSE linearity with temperature	—	± 1.5	—	°C
Avg_Slope	Average slope	—	4.4	—	mV/°C
V_{25}	Voltage at 25 °C	—	1.4	—	V
$t_{S_temp}^{(2)}$	ADC sampling time when reading the temperature	—	17.1	—	μ s

- (1) Based on characterization, not tested in production.
(2) Shortest sampling time can be determined in the application by multiple iterations.

4.14. DAC characteristics

Table 4-33. DAC characteristics

Symbol	Parameter	Conditions	Min	Typ	Max	Unit
$V_{DDA}^{(1)}$	Operating voltage	—	2.6	3.3	3.6	V
$V_{REFP}^{(2)}$	Positive Reference Voltage	—	2.6	—	V_{DDA}	V
$V_{REFN}^{(2)}$	Negative Reference Voltage	—	—	V_{SSA}	—	V
$R_{LOAD}^{(2)}$	Resistive load	Resistive load with buffer ON	5	—	—	k Ω
$R_o^{(2)}$	Impedance output	Impedance output with buffer OFF	—	—	15	k Ω
$C_{LOAD}^{(2)}$	Capacitive load	Capacitive load with buffer ON	—	—	50	pF

Symbol	Parameter	Conditions	Min	Typ	Max	Unit
DAC_OUT min ⁽²⁾	Lower DAC_OUT voltage	Lower DAC_OUT voltage with buffer ON	0.2	—	—	V
		Lower DAC_OUT voltage with buffer OFF	0.5	—	—	mV
DAC_OUT max ⁽²⁾	Higher DAC_OUT voltage	Higher DAC_OUT voltage with buffer ON	—	—	V _{DDA} - 0.2	V
		Higher DAC_OUT voltage with buffer OFF	—	—	V _{DDA} - 1LSB	V
I _{DDA} ⁽¹⁾	DAC current consumption in quiescent mode	With no load, middle code(0x800) on the input, V _{REFP} = 3.6 V	—	350	—	μA
		With no load, worst code(0xF1C) on the input, V _{REFP} = 3.6 V	—	430	—	
I _{DDVREFP} ⁽¹⁾	DAC current consumption in quiescent mode	With no load, middle code(0x800) on the input, V _{REFP} = 3.6 V	—	115	—	μA
		With no load, worst code(0xF1C) on the input, V _{REFP} = 3.6 V	—	298	—	
DNL ⁽¹⁾	Differential non linearity	10-bit configuration	—	—	±0.75	LSB
		12-bit configuration	—	—	±3	
INL ⁽¹⁾	Integral non linearity	10-bit configuration	—	—	±1.25	LSB
		12-bit configuration	—	—	±5	
Offset ⁽¹⁾	Offset error	DAC in 12-bit mode	—	—	±24	LSB
GE ⁽¹⁾	Gain error	DAC in 12-bit mode	—	—	±1.5	%
T _{setting} ⁽¹⁾	Settling time	C _{LOAD} ≤ 50 pF, R _{LOAD} ≥ 5 kΩ	—	0.5	1	μs
T _{wakeup} ⁽²⁾	Wakeup from off state	—	—	5	10	μs
Update rate ⁽²⁾	Max frequency for a correct DAC_OUT change from code i to i±1LSB	C _{LOAD} ≤ 50 pF, R _{LOAD} ≥ 5 kΩ	—	—	4	MS/s
PSRR ⁽²⁾	Power supply rejection ratio(to V _{DDA})	No R _{Load} , C _{LOAD} =50 pF	—	-90	—	dB

(1) Based on characterization, not tested in production.

(2) Guaranteed by design, not tested in production.

4.15. I2C characteristics

Table 4-34. I2C characteristics⁽¹⁾⁽²⁾

Symbol	Parameter	Conditions	Standard mode		Fast mode		Unit
			Min	Max	Min	Max	
t _{SCL(H)}	SCL clock high time	—	4.0	—	0.6	—	μs

Symbol	Parameter	Conditions	Standard mode		Fast mode		Unit
			Min	Max	Min	Max	
$t_{SCL(L)}$	SCL clock low time	—	4.7	—	1.3	—	μs
$t_{SU(SDA)}$	SDA setup time	—	250	—	100	—	ns
$t_{H(SDA)}$	SDA data hold time	—	0 ⁽³⁾	3450	0	900	ns
$t_{r(SDA/SCL)}$	SDA and SCL rise time	—	—	1000	—	300	ns
$t_{f(SDA/SCL)}$	SDA and SCL fall time	—	—	300	—	300	ns
$t_{H(STA)}$	Start condition hold time	—	4.0	—	0.6	—	μs
$t_{SU(STA)}$	Repeated Start condition setup time	—	4.7	—	0.6	—	μs
$t_{SU(STO)}$	Stop condition setup time	—	4.0	—	0.6	—	μs
t_{buff}	Stop to Start condition time (bus free)	—	4.7	—	1.3	—	μs

- (1) Guaranteed by design, not tested in production.
- (2) To ensure the standard mode I2C frequency, f_{PCLK1} must be at least 2 MHz. To ensure the fast mode I2C frequency, f_{PCLK1} must be at least 4 MHz.
- (3) The device should provide a data hold time of 300 ns at least in order to bridge the undefined region of the falling edge of SCL.

Figure 4-6. I2C bus timing diagram

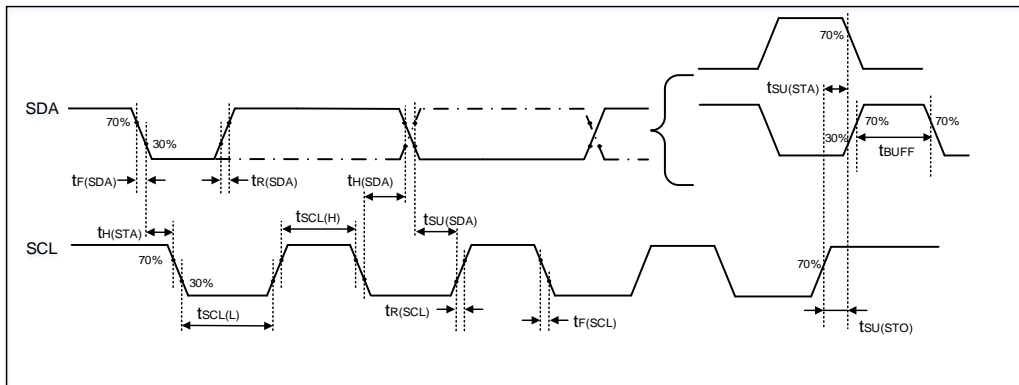

4.16. SPI characteristics

Table 4-35. Standard SPI characteristics⁽¹⁾

Symbol	Parameter	Conditions	Min	Typ	Max	Unit
f_{SCK}	SCK clock frequency	—	—	—	30	MHz
$t_{SCK(H)}$	SCK clock high time	Master mode, $f_{PCLKx} = 120\text{ MHz}$, presc = 4	14.67	16.67	18.67	ns
$t_{SCK(L)}$	SCK clock low time	Master mode, $f_{PCLKx} = 120\text{ MHz}$, presc = 4	14.67	16.67	18.67	ns
SPI master mode						
$t_{V(MO)}$	Data output valid time	—	—	—	8	ns
$t_{SU(MI)}$	Data input setup time	—	6	—	—	ns
$t_{H(MI)}$	Data input hold time	—	0	—	—	ns
SPI slave mode						
$t_{SU(NSS)}$	NSS enable setup time	—	0	—	—	ns
$t_{H(NSS)}$	NSS enable hold time	—	3.3	—	—	ns
$t_{A(SO)}$	Data output access time	—	—	9	—	ns
$t_{DIS(SO)}$	Data output disable time	—	—	10	—	ns
$t_{V(SO)}$	Data output valid time	—	—	11	—	ns
$t_{SU(SI)}$	Data input setup time	—	0	—	—	ns
$t_{H(SI)}$	Data input hold time	—	2.2	—	—	ns

(1) Based on characterization, not tested in production.

Figure 4-7. SPI timing diagram - master mode

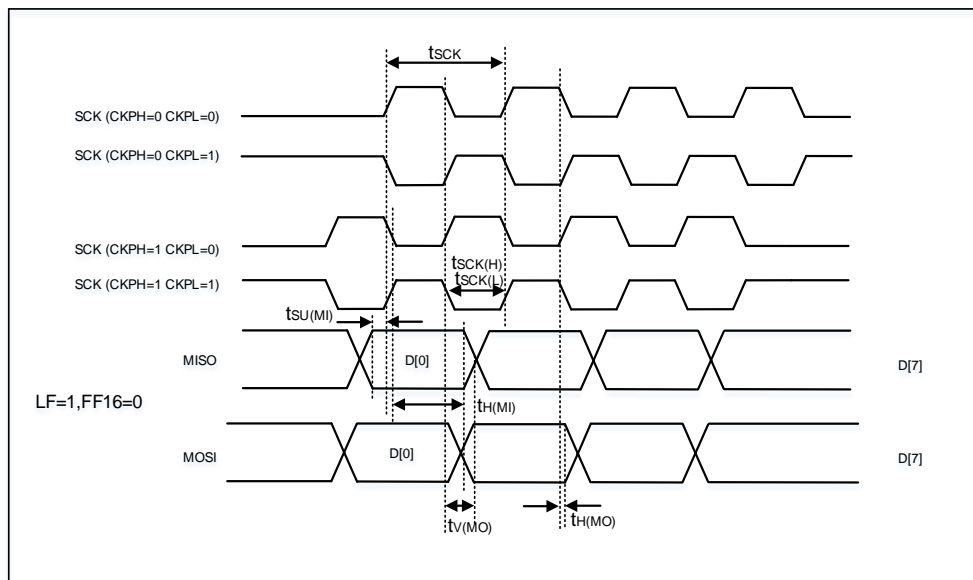
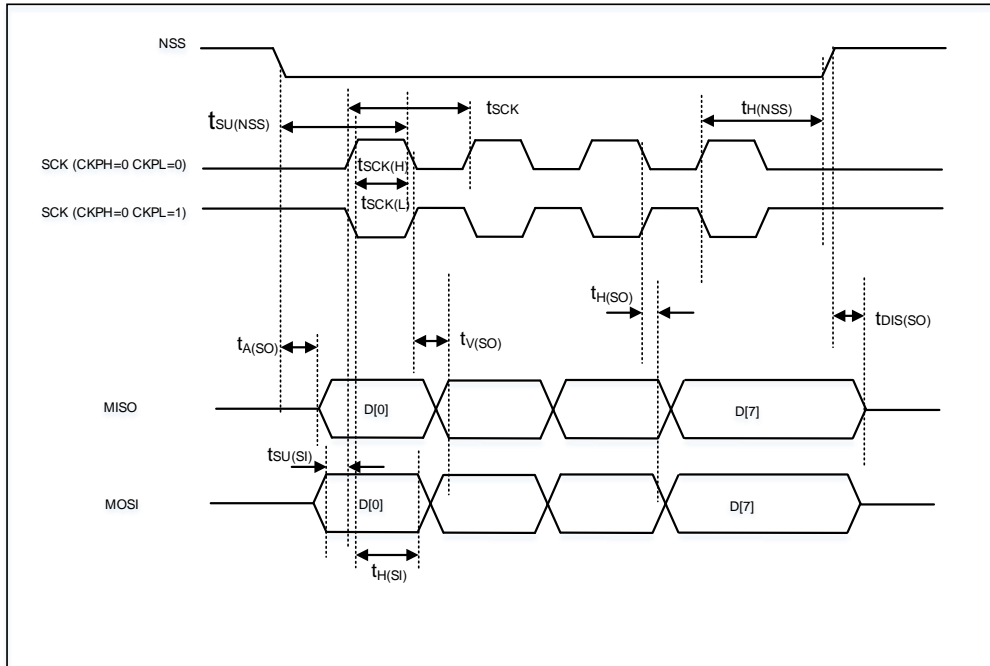

Figure 4-8. SPI timing diagram - slave mode



4.17. I2S characteristics

Table 4-36. I2S characteristics⁽¹⁾⁽²⁾

Symbol	Parameter	Conditions	Min	Typ	Max	Unit
f_{CK}	Clock frequency	Master mode (data: 32 bits, Audio frequency = 96 kHz)	—	6.25	—	MHz
		Slave mode	—	—	12.5	
t_H	Clock high time	—	—	80	—	ns
t_L	Clock low time		—	80	—	ns
$t_{V(WS)}$	WS valid time	Master mode	—	3	—	ns
$t_{H(WS)}$	WS hold time	Master mode	—	3	—	ns
$t_{SU(WS)}$	WS setup time	Slave mode	0	—	—	ns
$t_{H(WS)}$	WS hold time	Slave mode	3	—	—	ns
$D_{CY(SCK)}$	I2S slave input clock duty cycle	Slave mode	—	50	—	%
$t_{SU(SD_MR)}$	Data input setup time	Master mode	0	—	—	ns
$t_{SU(SD_SR)}$	Data input setup time	Slave mode	0	—	—	ns
$t_{H(SD_MR)}$	Data input hold time	Master receiver	1	—	—	ns
$t_{H(SD_SR)}$		Slave receiver	3	—	—	ns
$t_{V(SD_ST)}$	Data output valid time	Slave transmitter (after enable edge)	—	—	9	ns
$t_{H(SD_ST)}$	Data output hold time	Slave transmitter (after enable edge)	6	—	—	ns
$t_{V(SD_MT)}$	Data output valid time	Master transmitter (after enable edge)	—	—	6	ns
$t_{H(SD_MT)}$	Data output hold time	Master transmitter (after enable edge)	0	—	—	ns

(1) Guaranteed by design, not tested in production.

(2) Based on characterization, not tested in production.

Figure 4-9. I2S timing diagram - master mode

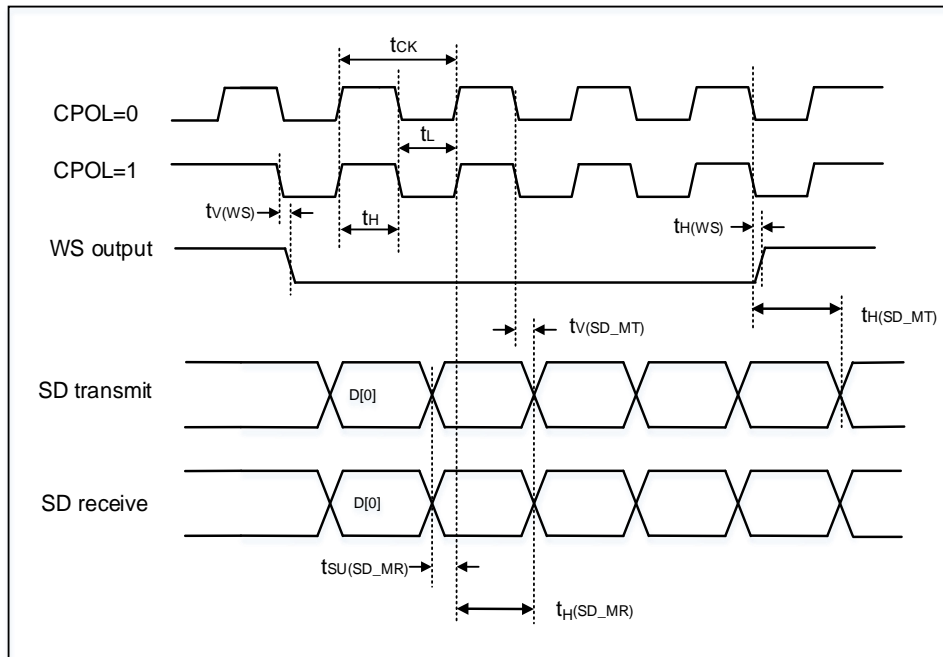
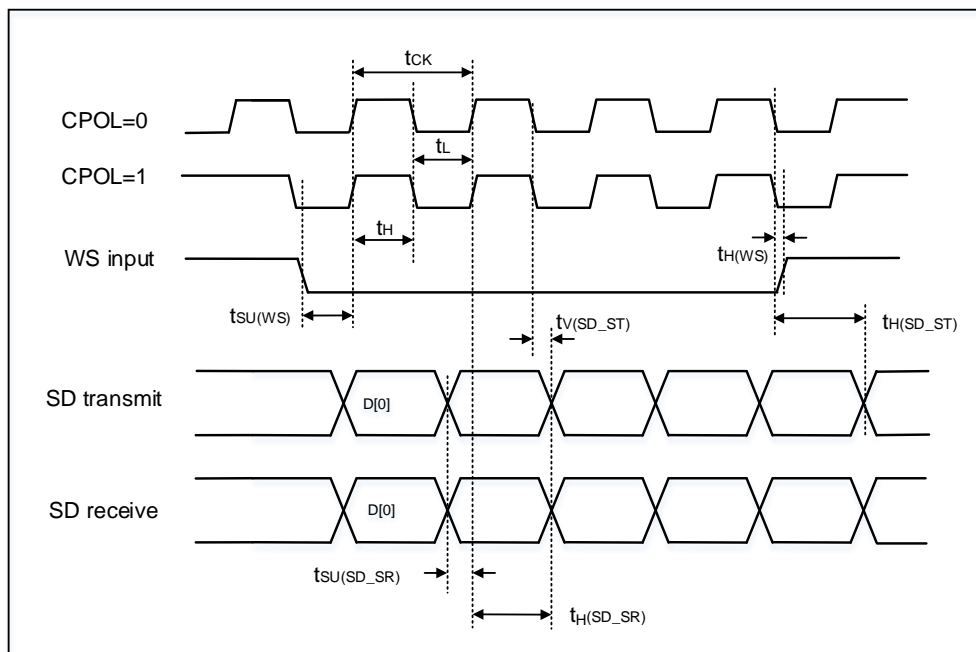

Figure 4-10. I2S timing diagram - slave mode



4.18. USART characteristics

Table 4-37. USART characteristics⁽¹⁾

Symbol	Parameter	Conditions	Min	Typ	Max	Unit
f_{SCK}	SCK clock frequency	$f_{PCLKx} = 100 \text{ MHz}$	—	—	50	MHz
$t_{SCK(H)}$	SCK clock high time	$f_{PCLKx} = 100 \text{ MHz}$	10	—	—	ns
$t_{SCK(L)}$	SCK clock low time	$f_{PCLKx} = 100 \text{ MHz}$	10	—	—	ns

(1) Guaranteed by design, not tested in production.

4.19. SDIO characteristics

Table 4-38. SDIO characteristics⁽¹⁾⁽²⁾

Symbol	Parameter	Conditions	Min	Typ	Max	Unit
$f_{PP}^{(3)}$	Clock frequency in data transfer mode	—	0	—	48	MHz
$t_{W(CKL)}^{(3)}$	Clock low time	$f_{pp} = 48 \text{ MHz}$	9.5	10.5	—	ns
$t_{W(CKH)}^{(3)}$	Clock high time	$f_{pp} = 48 \text{ MHz}$	9.3	10.3	—	ns
CMD, D inputs (referenced to CK) in MMC and SD HS mode						
$t_{ISU}^{(4)}$	Input setup time HS	$f_{pp} = 48 \text{ MHz}$	4	—	—	ns
$t_{IH}^{(4)}$	Input hold time HS	$f_{pp} = 48 \text{ MHz}$	3	—	—	ns
CMD, D outputs (referenced to CK) in MMC and SD HS mode						
$t_{OV}^{(3)}$	Output valid time HS	$f_{pp} = 48 \text{ MHz}$	—	—	13.8	ns
$t_{OH}^{(3)}$	Output hold time HS	$f_{pp} = 48 \text{ MHz}$	12	—	—	ns
CMD, D inputs (referenced to CK) in SD default mode						
$t_{ISUD}^{(4)}$	Input setup time SD	$f_{pp} = 24 \text{ MHz}$	3	—	—	ns
$t_{IHD}^{(4)}$	Input hold time SD	$f_{pp} = 24 \text{ MHz}$	3	—	—	ns
CMD, D outputs (referenced to CK) in SD default mode						
$t_{OVD}^{(3)}$	Output valid default time SD	$f_{pp} = 24 \text{ MHz}$	—	2.4	2.8	ns
$t_{OHD}^{(3)}$	Output hold default time SD	$f_{pp} = 24 \text{ MHz}$	2	—	—	ns

(1) CLK timing is measured at 50% of V_{DD} .

(2) Capacitive load $C_L = 30 \text{ pF}$.

(3) Based on characterization, not tested in production.

(4) Guaranteed by design, not tested in production.

4.20. CAN characteristics

Refer to **Table 4-26. I/O port DC characteristics⁽¹⁾⁽³⁾** for more details on the input/output alternate function characteristics (CANTX and CANRX).

4.21. USBFS characteristics

Table 4-39. USBFS start up time

Symbol	Parameter	Max	Unit
$t_{STARTUP}^{(1)}$	USBFS startup time	1	μs

(1) Guaranteed by design, not tested in production.

Table 4-40. USBFS DC electrical characteristics

Symbol	Parameter	Conditions	Min	Typ	Max	Unit	
Input levels ⁽¹⁾	V_{DD}	USBFS operating voltage	—	3	—	3.6	V
	V_{DI}	Differential input sensitivity	—	0.2	—	—	V
	V_{CM}	Differential common mode range	Includes V_{DI} range	0.8	—	2.5	
	V_{SE}	Single ended receiver threshold	—	1.3	—	2.0	
Output levels ⁽²⁾	V_{OL}	Static output level low	R_L of 1.0 k Ω to 3.6 V	—	0.06	0.3	V
	V_{OH}	Static output level high	R_L of 15 k Ω to V_{SS}	2.8	3.3	3.6	
$R_{PD}^{(2)}$	PA11, PA12(USBFS_DM/DP) PB14, PB15(USBHS_DM/DP)	$V_{IN} = V_{DD}$	17	21	25	k Ω	
	PA9(USBFS_VBUS) PB13(USBHS_VBUS)		0.72	0.9	1.1		
$R_{PU}^{(2)}$	PA11, PA12(USBFS_DM/DP) PB14, PB15(USBHS_DM/DP)	$V_{IN} = V_{SS}$	1.2	1.5	1.8		
	PA9(USBFS_VBUS) PB13(USBHS_VBUS)		0.24	0.3	0.33		

(1) Guaranteed by design, not tested in production.

(2) Based on characterization, not tested in production.

Table 4-41. USBFS full speed-electrical characteristics⁽¹⁾

Symbol	Parameter	Conditions	Min	Typ	Max	Unit
t_R	Rise time	$C_L = 50$ pF	4	—	20	ns
t_F	Fall time	$C_L = 50$ pF	4	—	20	ns
t_{RFM}	Rise/ fall time matching	t_R / t_F	90	—	110	%
V_{CRS}	Output signal crossover voltage	—	1.3	—	2.0	V

(1) Guaranteed by design, not tested in production.

Figure 4-11. USBFS timings: definition of data signal rise and fall time

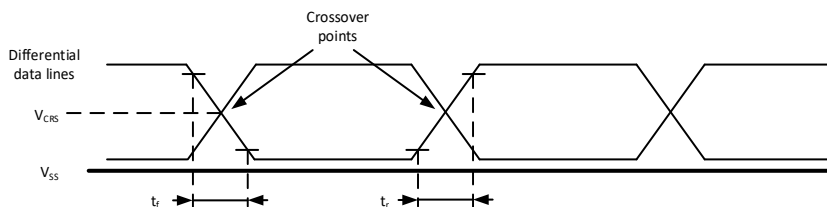

4.22. USBHS characteristics

Table 4-42. USBHS clock timing parameters⁽¹⁾

Symbol	Parameter	Min	Typ	Max	Unit
V _{DD}	USBHS operating voltage	3.0	—	3.6	V
f _{HCLK}	f _{HCLK} value to guarantee proper operation of USBHS interface	30	—	—	MHz
F _{START_8BIT}	Frequency (first transition) 8-bit ± 10%	54	60	66	MHz
F _{STEADY}	Frequency (steady state) ±500 ppm	59.97	60	60.63	MHz
D _{START_8BIT}	Duty cycle (first transition) 8-bit ± 10%	40	50	60	%
D _{STEADY}	Duty cycle (steady state) ±500 ppm	49.975	50	50.025	%

(1) Guaranteed by design, not tested in production.

Table 4-43. USB-ULPI Dynamic characteristics

Symbol	Parameter	Min	Typ	Max	Unit
t _{SC}	Control in (ULPI_DIR, ULPI_NXT) setup time	—	—	2	ns
t _{HC}	Control in (ULPI_DIR, ULPI_NXT) hold time	0.5	—	—	ns
t _{SD}	Data in setup time	—	—	2	ns
t _{HD}	Data in hold time	0	—	—	ns

(1) Guaranteed by design, not tested in production.

4.23. Ethernet (ENET) characteristics

Table 4-44. Dynamics characteristics: Ethernet MAC signals for SMI⁽¹⁾

Symbol	Parameter	Min	Typ	Max	Unit
t _{MDC}	MDC cycle time(2.38 MHz)	411	420	425	ns
T _{D(MDIO)}	Write data valid delay time	1/4 t _{mdc}	1/4 t _{mdc}	1/4 t _{mdc}	
t _{SU(MDIO)}	Read data setup time	12	—	—	
t _{H(SD_MR)}	Read data hold time	0	—	—	

(1) Guaranteed by design, not tested in production.

Figure 4-12. Ethernet SMI timing diagram

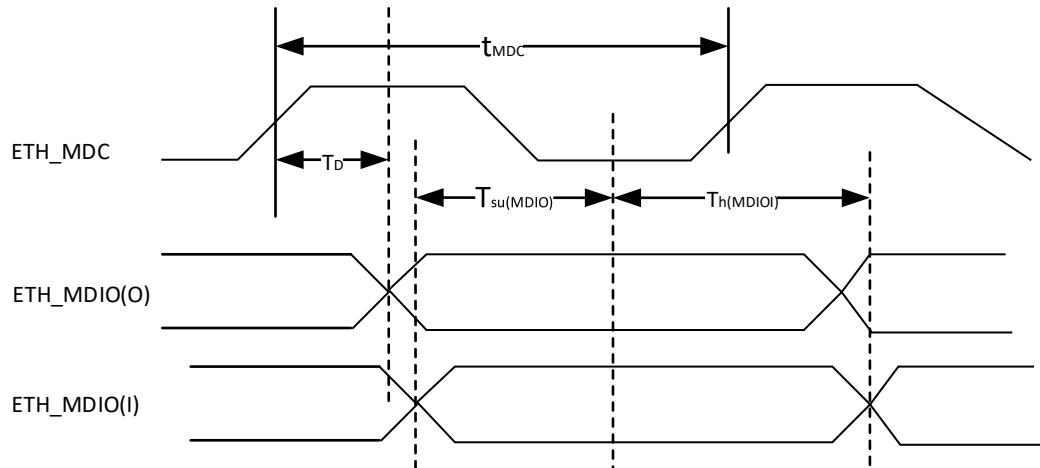

4.24. EXMC characteristics

Table 4-45. Asynchronous non-multiplexed SRAM/PSRAM/NOR read timings⁽¹⁾⁽²⁾⁽³⁾

Symbol	Parameter	Min	Max	Unit
$t_{w(NE)}$	EXMC_NE low time	24	26	ns
$t_{v(NO_NE)}$	EXMC_NEx low to EXMC_NOE low	0	—	ns
$t_{w(NO)}$	EXMC_NOE low time	24	26	ns
$t_{h(NE_NO)}$	EXMC_NOE high to EXMC_NE high hold time	0	—	ns
$t_{v(A_NE)}$	EXMC_NEx low to EXMC_A valid	0	—	ns
$t_{v(BL_NE)}$	EXMC_NEx low to EXMC_BL valid	0	—	ns
$t_{su(DATA_NE)}$	Data to EXMC_NEx high setup time	19	—	ns
$t_{su(DATA_NO)}$	Data to EXMC_NOEx high setup time	19	—	ns
$t_{h(DATA_NO)}$	Data hold time after EXMC_NOE high	0	—	ns
$t_{h(DATA_NE)}$	Data hold time after EXMC_NEx high	0	—	ns
$t_{v(NADV_NE)}$	EXMC_NEx low to EXMC_NADV low	0	—	ns
$t_{w(NADV)}$	EXMC_NADV low time	4	6	ns

(1) $C_L = 30$ pF.

(2) Guaranteed by design, not tested in production.

(3) Based on configure: $f_{HCLK} = 200$ MHz, AddressSetupTime = 0, AddressHoldTime = 1, DataSetupTime = 1.

Table 4-46. Asynchronous non-multiplexed SRAM/PSRAM/NOR write timings⁽¹⁾⁽²⁾⁽³⁾

Symbol	Parameter	Min	Max	Unit
$t_{w(NE)}$	EXMC_NE low time	14	16	ns
$t_{v(NWE_NE)}$	EXMC_NEx low to EXMC_NWE low	4	—	ns
$t_{w(NWE)}$	EXMC_NWE low time	4	6	ns
$t_{h(NE_NWE)}$	EXMC_NWE high to EXMC_NE high hold time	4	6	ns
$t_{v(A_NE)}$	EXMC_NEx low to EXMC_A valid	0	—	ns
$t_{v(NADV_NE)}$	EXMC_NEx low to EXMC_NADV low	0	—	ns
$t_{w(NADV)}$	EXMC_NADV low time	4	6	ns
$t_{h(AD_NADV)}$	EXMC_AD(address) valid hold time after EXMC_NADV high	9	—	ns
$t_{h(A_NWE)}$	Address hold time after EXMC_NWE high	4	—	ns
$t_{h(BL_NWE)}$	EXMC_BL hold time after EXMC_NWE high	4	—	ns
$t_{v(BL_NE)}$	EXMC_NEx low to EXMC_BL valid	0	—	ns
$t_{v(DATA_NADV)}$	EXMC_NADV high to DATA valid	0	—	ns
$t_{h(DATA_NWE)}$	Data hold time after EXMC_NWE high	4	—	ns

(1) $C_L = 30$ pF.

(2) Guaranteed by design, not tested in production.

(3) Based on configure: $f_{HCLK} = 200$ MHz, AddressSetupTime = 0, AddressHoldTime = 1, DataSetupTime = 1.

Table 4-47. Asynchronous multiplexed PSRAM/NOR read timings⁽¹⁾⁽²⁾⁽³⁾

Symbol	Parameter	Min	Max	Unit
$t_{w(NE)}$	EXMC_NE low time	34	35	ns
$t_{v(NOE_NE)}$	EXMC_NEx low to EXMC_NOE low	14	—	ns
$t_{w(NOE)}$	EXMC_NOE low time	19	21	ns
$t_{h(NE_NOE)}$	EXMC_NOE high to EXMC_NE high hold time	0	—	ns
$t_{v(A_NE)}$	EXMC_NEx low to EXMC_A valid	0	—	ns
$t_{v(A_NOE)}$	Address hold time after EXMC_NOE high	0	—	ns
$t_{v(BL_NE)}$	EXMC_NEx low to EXMC_BL valid	0	—	ns
$t_{h(BL_NOE)}$	EXMC_BL hold time after EXMC_NOE high	0	—	ns
$t_{su(DATA_NE)}$	Data to EXMC_NEx high setup time	19	—	ns
$t_{su(DATA_NOE)}$	Data to EXMC_NOEx high setup time	19	—	ns
$t_{h(DATA_NOE)}$	Data hold time after EXMC_NOE high	0	—	ns
$t_{h(DATA_NE)}$	Data hold time after EXMC_NEx high	0	—	ns
$t_{v(NADV_NE)}$	EXMC_NEx low to EXMC_NADV low	0	—	ns
$t_{w(NADV)}$	EXMC_NADV low time	4	6	ns
$T_{h(AD_NADV)}$	EXMC_AD(address) valid hold time after EXMC_NADV high	4	6	ns

(1) $C_L = 30$ pF.

(2) Guaranteed by design, not tested in production.

(3) Based on configure: $f_{HCLK} = 200$ MHz, AddressSetupTime = 0, AddressHoldTime = 1, DataSetupTime = 1.

Table 4-48. Asynchronous multiplexed PSRAM/NOR write timings⁽¹⁾⁽²⁾⁽³⁾

Symbol	Parameter	Min	Max	Unit
$t_{w(NE)}$	EXMC_NE low time	24	26	ns

Symbol	Parameter	Min	Max	Unit
$t_{V(NWE_NE)}$	EXMC_NEx low to EXMC_NWE low	4	—	ns
$t_{w(NWE)}$	EXMC_NWE low time	14	16	ns
$t_{h(NE_NWE)}$	EXMC_NWE high to EXMC_NE high hold time	4	—	ns
$t_{V(A_NE)}$	EXMC_NEx low to EXMC_A valid	0	—	ns
$t_{V(NADV_NE)}$	EXMC_NEx low to EXMC_NADV low	0	—	ns
$t_{w(NADV)}$	EXMC_NADV low time	4	6	ns
$t_{h(AD_NADV)}$	EXMC_AD(address) valid hold time after EXMC_NADV high	4	—	ns
$t_{h(A_NWE)}$	Address hold time after EXMC_NWE high	4	—	ns
$t_{h(BL_NWE)}$	EXMC_BL hold time after EXMC_NWE high	4	—	ns
$t_{v(BL_NE)}$	EXMC_NEx low to EXMC_BL valid	0	—	ns
$t_{v(DATA_NADV)}$	EXMC_NADV high to DATA valid	4	—	ns
$t_{h(DATA_NWE)}$	Data hold time after EXMC_NWE high	4	—	ns

- (1) $C_L = 30$ pF.
(2) Guaranteed by design, not tested in production.
(3) Based on configure: $f_{HCLK} = 200$ MHz, AddressSetupTime = 0, AddressHoldTime = 1, DataSetupTime = 1.

Table 4-49. Synchronous multiplexed PSRAM/NOR read timings⁽¹⁾⁽²⁾⁽³⁾

Symbol	Parameter	Min	Max	Unit
$t_{w(CLK)}$	EXMC_CLK period	20	—	ns
$t_{d(CLKL-NExL)}$	EXMC_CLK low to EXMC_NEx low	0	—	ns
$t_{d(CLKH-NExH)}$	EXMC_CLK high to EXMC_NEx high	9	—	ns
$t_{d(CLKL-NADV L)}$	EXMC_CLK low to EXMC_NADV low	0	—	ns
$t_{d(CLKL-NADV H)}$	EXMC_CLK low to EXMC_NADV high	0	—	ns
$t_{d(CLKL-AV)}$	EXMC_CLK low to EXMC_Ax valid	0	—	ns
$t_{d(CLKH-AIV)}$	EXMC_CLK high to EXMC_Ax invalid	9	—	ns
$t_{d(CLKL-NOEL)}$	EXMC_CLK low to EXMC_NOE low	0	—	ns
$t_{d(CLKH-NOEH)}$	EXMC_CLK high to EXMC_NOE high	9	—	ns
$t_{d(CLKL-ADV)}$	EXMC_CLK low to EXMC_AD valid	0	—	ns
$t_{d(CLKL-ADIV)}$	EXMC_CLK low to EXMC_AD invalid	0	—	ns

- (1) $C_L = 30$ pF.
(2) Guaranteed by design, not tested in production.
(3) Based on configure: $f_{HCLK} = 200$ MHz, BurstAccessMode = Enable; Memory Type = PSRAM; WriteBurst = Enable; CLKDivision = 3 (EXMC_CLK is 4 divided by HCLK); Data Latency = 1.

Table 4-50. Synchronous multiplexed PSRAM write timings⁽¹⁾⁽²⁾⁽³⁾

Symbol	Parameter	Min	Max	Unit
$t_{w(CLK)}$	EXMC_CLK period	20	—	ns
$t_{d(CLKL-NExL)}$	EXMC_CLK low to EXMC_NEx low	0	—	ns
$t_{d(CLKH-NExH)}$	EXMC_CLK high to EXMC_NEx high	9	—	ns
$t_{d(CLKL-NADV L)}$	EXMC_CLK low to EXMC_NADV low	0	—	ns
$t_{d(CLKL-NADV H)}$	EXMC_CLK low to EXMC_NADV high	0	—	ns
$t_{d(CLKL-AV)}$	EXMC_CLK low to EXMC_Ax valid	0	—	ns
$t_{d(CLKH-AIV)}$	EXMC_CLK high to EXMC_Ax invalid	9	—	ns

Symbol	Parameter	Min	Max	Unit
$t_{d(CLKL-NWEL)}$	EXMC_CLK low to EXMC_NWE low	0	—	ns
$t_{d(CLKH-NWEH)}$	EXMC_CLK high to EXMC_NWE high	9	—	ns
$t_{d(CLKL-ADIV)}$	EXMC_CLK low to EXMC_AD invalid	0	—	ns
$t_{d(CLKL-DATA)}$	EXMC_A/D valid data after EXMC_CLK low	0	—	ns
$t_{h(CLKL-NBLH)}$	EXMC_CLK low to EXMC_NBL high	0	—	ns

- (1) $C_L = 30$ pF.
- (2) Guaranteed by design, not tested in production.
- (3) Based on configure: $f_{HCLK} = 200$ MHz, BurstAccessMode = Enable; MemoryType = PSRAM; WriteBurst = Enable; CLKDivision = 3 (EXMC_CLK is 4 divided by HCLK); DataLatency = 1.

Table 4-51. Synchronous non-multiplexed PSRAM/NOR read timings⁽¹⁾⁽²⁾⁽³⁾

Symbol	Parameter	Min	Max	Unit
$t_{w(CLK)}$	EXMC_CLK period	20	—	ns
$t_{d(CLKL-NEXL)}$	EXMC_CLK low to EXMC_NEx low	0	—	ns
$t_{d(CLKH-NExH)}$	EXMC_CLK high to EXMC_NEx high	9	—	ns
$t_{d(CLKL-NADV L)}$	EXMC_CLK low to EXMC_NADV low	0	—	ns
$t_{d(CLKL-NADV H)}$	EXMC_CLK low to EXMC_NADV high	0	—	ns
$t_{d(CLKL-AV)}$	EXMC_CLK low to EXMC_Ax valid	0	—	ns
$t_{d(CLKH-AIV)}$	EXMC_CLK high to EXMC_Ax invalid	9	—	ns
$t_{d(CLKL-NOEL)}$	EXMC_CLK low to EXMC_NOE low	0	—	ns
$t_{d(CLKH-NOEH)}$	EXMC_CLK high to EXMC_NOE high	9	—	ns

- (1) $C_L = 30$ pF.
- (2) Guaranteed by design, not tested in production.
- (3) Based on configure: $f_{HCLK} = 200$ MHz, BurstAccessMode = Enable; MemoryType = PSRAM; WriteBurst = Enable; CLKDivision = 3 (EXMC_CLK is 4 divided by HCLK); DataLatency = 1.

Table 4-52. Synchronous non-multiplexed PSRAM write timings⁽¹⁾⁽²⁾⁽³⁾

Symbol	Parameter	Min	Max	Unit
$t_{w(CLK)}$	EXMC_CLK period	20	—	ns
$t_{d(CLKL-NEXL)}$	EXMC_CLK low to EXMC_NEx low	0	—	ns
$t_{d(CLKH-NExH)}$	EXMC_CLK high to EXMC_NEx high	9	—	ns
$t_{d(CLKL-NADV L)}$	EXMC_CLK low to EXMC_NADV low	0	—	ns
$t_{d(CLKL-NADV H)}$	EXMC_CLK low to EXMC_NADV high	0	—	ns
$t_{d(CLKL-AV)}$	EXMC_CLK low to EXMC_Ax valid	0	—	ns
$t_{d(CLKH-AIV)}$	EXMC_CLK high to EXMC_Ax invalid	9	—	ns
$t_{d(CLKL-NWEL)}$	EXMC_CLK low to EXMC_NWE low	0	—	ns
$t_{d(CLKH-NWEH)}$	EXMC_CLK high to EXMC_NWE high	9	—	ns
$t_{d(CLKL-DATA)}$	EXMC_A/D valid data after EXMC_CLK low	0	—	ns
$t_{h(CLKL-NBLH)}$	EXMC_CLK low to EXMC_NBL high	0	—	ns

- (1) $C_L = 30$ pF.
- (2) Guaranteed by design, not tested in production.
- (3) Based on configure: $f_{HCLK} = 200$ MHz, BurstAccessMode = Enable; MemoryType = PSRAM; WriteBurst = Enable; CLKDivision = 3 (EXMC_CLK is 4 divided by HCLK); DataLatency = 1.

4.25. TIMER characteristics

Table 4-53. TIMER characteristics⁽¹⁾

Symbol	Parameter	Conditions	Min	Max	Unit
t _{res}	Timer resolution time	—	1	—	t _{TIMERxCLK}
		f _{TIMERxCLK} = 200 MHz	5	—	ns
f _{EXT}	Timer external clock frequency	—	0	f _{TIMERxCLK} /2	MHz
		f _{TIMERxCLK} = 200 MHz	0	100	MHz
RES	Timer resolution	TIMERx (except TIMER1 & TIMER4)	—	16	bit
		TIMER1 & TIMER4	—	32	bit
t _{COUNTER}	16-bit counter clock period when internal clock is selected	—	1	65536	t _{TIMERxCLK}
		f _{TIMERxCLK} = 200 MHz	0.005	327.68	µs
t _{MAX_COUNT}	Maximum possible count	—	—	65536x65536	t _{TIMERxCLK}
		f _{TIMERxCLK} = 200 MHz	—	21.47	s

(1) Guaranteed by design, not tested in production.

4.26. DCI characteristics

Table 4-54. DCI characteristics⁽¹⁾

Symbol	Parameter	Min	Max	Unit
Frequency ratio	DCI_PIXCLK /fHCLK	—	0.4	
DCI_PIXCLK	Pixel clock input	—	80	MHz
D _{Pixel}	Pixel clock input duty cycle	30	70	%
t _{su} (DATA)	Data input setup time	2.5	—	ns
t _h (DATA)	Data input hold time	1	—	ns
t _{su} (HS)	DCI_HS input setup time	2	—	ns
t _{su} (VS)	DCI_VS input setup time	2	—	ns
t _h (HS)	DCI_HS input hold time	0.5	—	ns
t _h (VS)	DCI_VS input hold time	0.5	—	ns

(1) Guaranteed by design, not tested in production.

4.27. WDGT characteristics

Table 4-55. FWDGT min/max timeout period at 32 kHz (IRC32K)⁽¹⁾

Prescaler divider	PSC[2:0] bits	Min timeout RLD[11:0] = 0x000	Max timeout RLD[11:0] = 0xFF	Unit
1/4	000	0.03125	511.90625	ms
1/8	001	0.03125	1023.7812	
1/16	010	0.03125	2047.53125	
1/32	011	0.03125	4095.03125	
1/64	100	0.03125	8190.03125	
1/128	101	0.03125	16380.03125	
1/256	110 or 111	0.03125	32760.03125	

(1) Guaranteed by design, not tested in production.

Table 4-56. WWDGT min-max timeout value at 50 MHz (f_{PCLK1})⁽¹⁾

Prescaler divider	PSC[1:0]	Min timeout value CNT[6:0] = 0x40	Unit	Max timeout value CNT[6:0] = 0x7F	Unit
1/1	00	81.92	μs	5.24	ms
1/2	01	163.84		10.48	
1/4	10	327.68		20.96	
1/8	11	655.36		41.92	

(1) Guaranteed by design, not tested in production.

4.28. Parameter conditions

Unless otherwise specified, all values given for $V_{DD} = V_{DDA} = 3.3\text{ V}$, $T_A = 25\text{ °C}$.

5. Package information

5.1 BGA176 package outline dimensions

Figure 5-1. BGA176 package outline

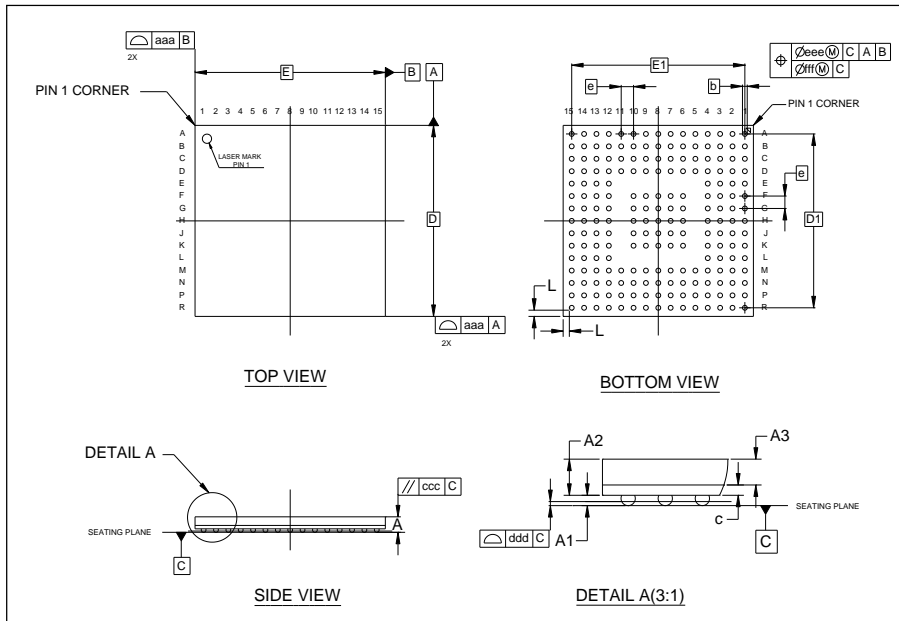
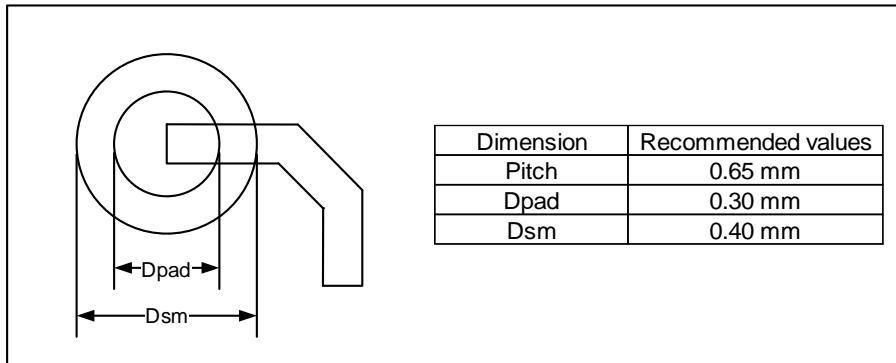

Table 5-1. BGA176 package dimensions

Symbol	Min	Typ	Max
A	—	—	0.89
A1	0.13	0.18	0.23
A2	0.58	0.63	0.68
A3	—	0.45	—
b	0.20	0.25	0.30
c	0.15	0.18	0.21
D	9.90	10.00	10.10
D1	—	9.10	—
E	9.90	10.00	10.10
E1	—	9.10	—
e	—	0.65	—
L	—	0.325	—
aaa	—	0.10	—
ccc	—	0.20	—
ddd	—	0.08	—
eee	—	0.15	—
fff	—	0.08	—

(Original dimensions are in millimeters)

Figure 5-2. BGA176 recommended footprint



(Original dimensions are in millimeters)

5.2 LQFP144 package outline dimensions

Figure 5-3. LQFP144 package outline

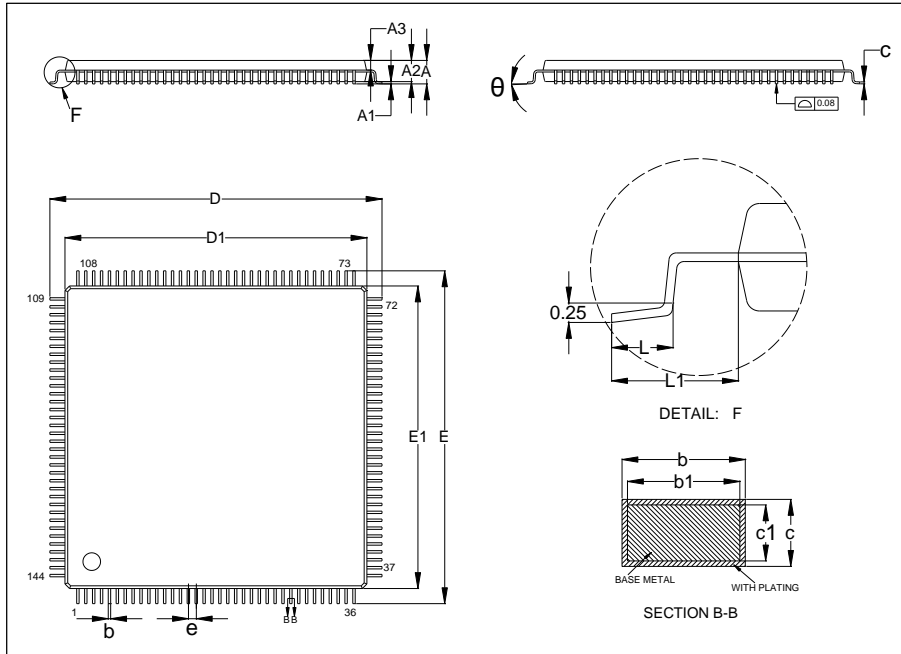
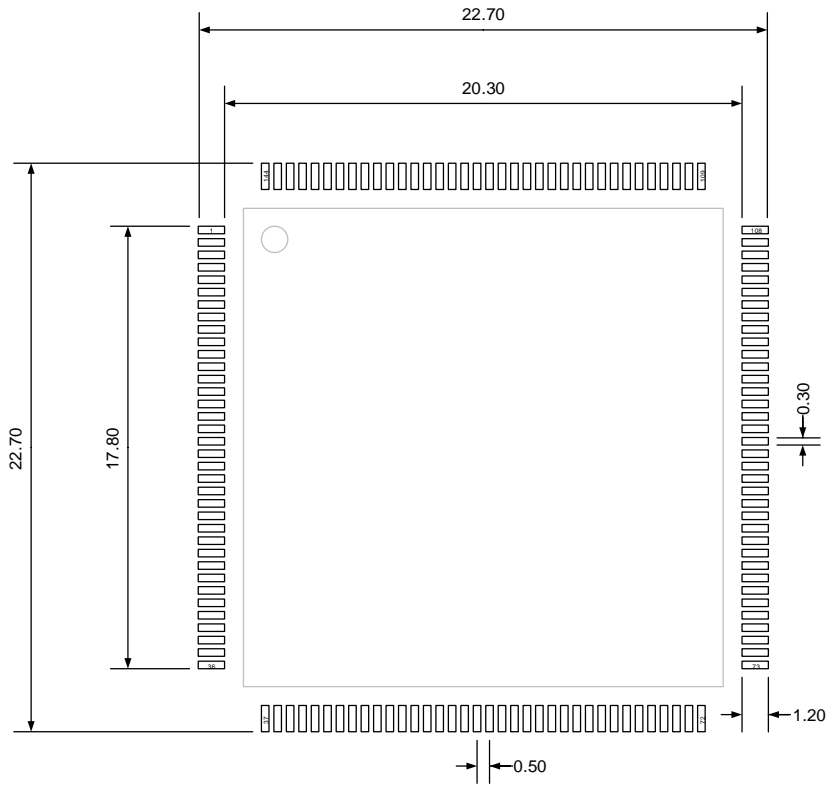

Table 5-2. LQFP144 package dimensions

Symbol	Min	Typ	Max
A	—	—	1.60
A1	0.05	—	0.15
A2	1.35	1.40	1.45
A3	0.59	0.64	0.69
b	0.18	—	0.26
b1	0.17	0.20	0.23
c	0.13	—	0.17
c1	0.12	0.13	0.14
D	21.80	22.00	22.20
D1	19.90	20.00	20.10
E	21.80	22.00	22.20
E1	19.90	20.00	20.10
e	—	0.50	—
L	0.45	—	0.75
L1	—	1.00	—
θ	0°	—	7°

(Original dimensions are in millimeters)

Figure 5-4. LQFP144 recommended footprint



(Original dimensions are in millimeters)

5.3 BGA100 package outline dimensions

Figure 5-5. BGA100 package outline

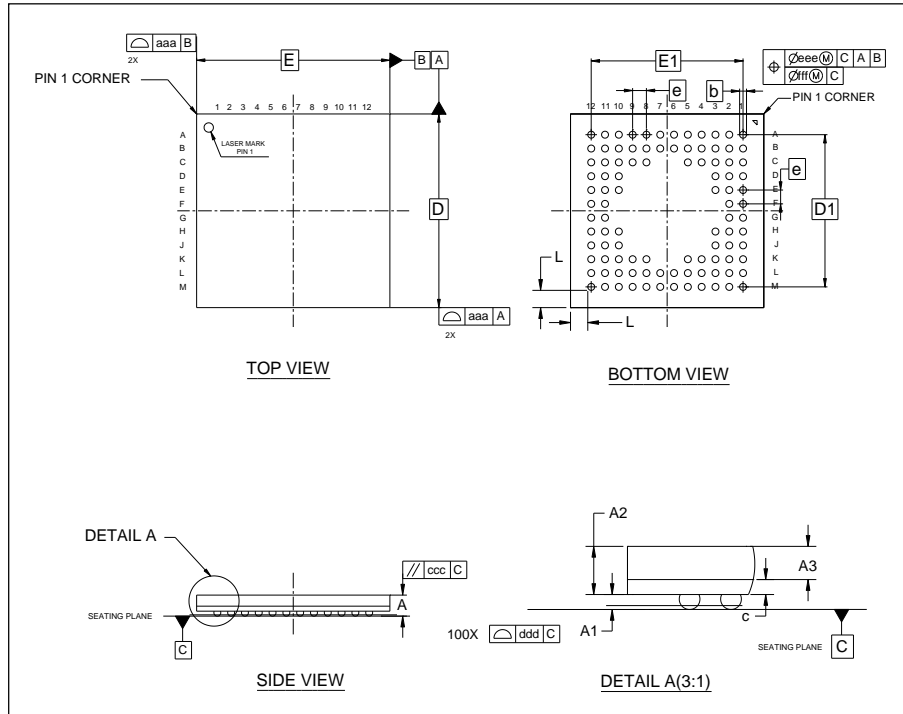
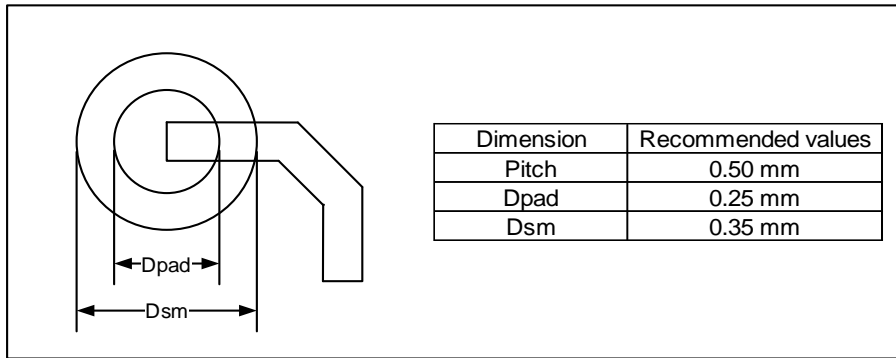

Table 5-3. BGA100 package dimensions

Symbol	Min	Typ	Max
A	—	—	0.84
A1	0.13	0.18	0.23
A2	0.53	0.58	0.63
A3	—	0.40	—
b	0.20	0.25	0.30
c	0.15	0.18	0.21
D	6.90	7.00	7.10
D1	—	5.50	—
E	6.90	7.00	7.10
E1	—	5.50	—
e	—	0.50	—
L	—	0.625	—
aaa	—	0.10	—
ccc	—	0.20	—
ddd	—	0.08	—
eee	—	0.15	—
fff	—	0.08	—

(Original dimensions are in millimeters)

Figure 5-6. BGA100 recommended footprint



(Original dimensions are in millimeters)

5.4 LQFP100 package outline dimensions

Figure 5-7. LQFP100 package outline

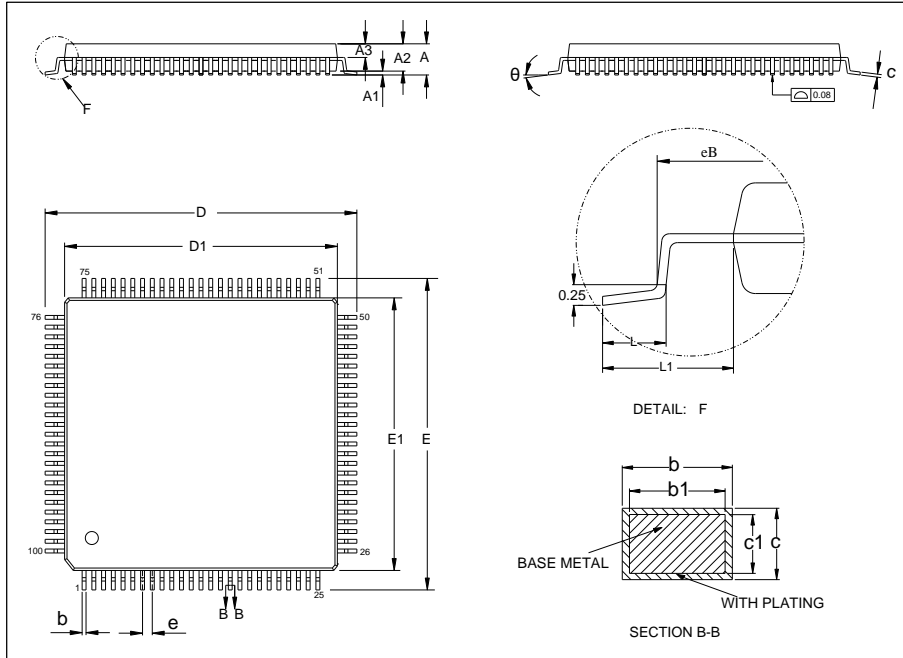
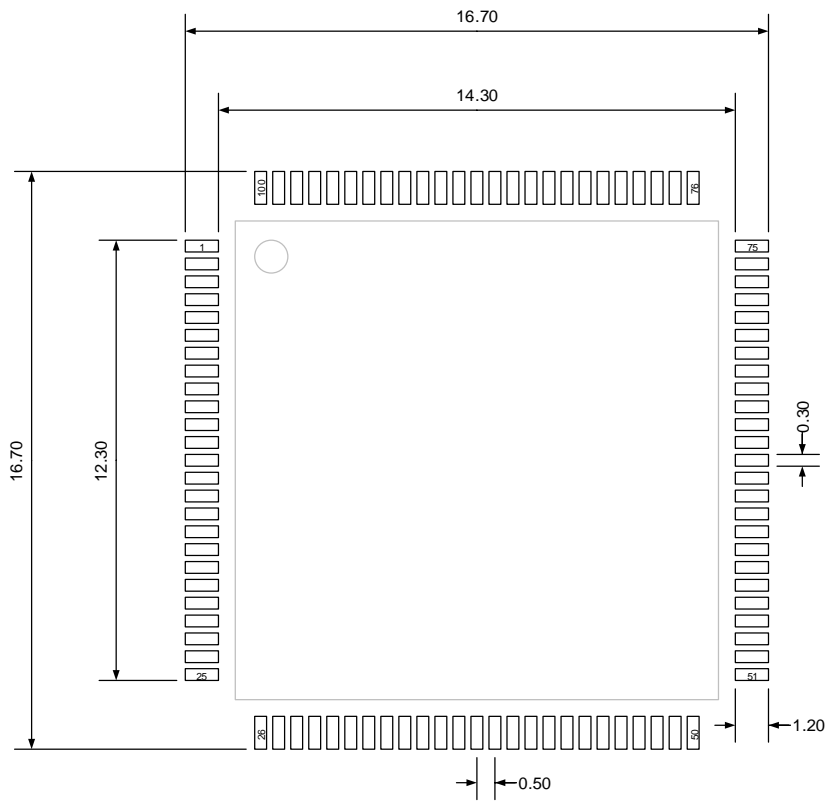

Table 5-4. LQFP100 package dimensions

Symbol	Min	Typ	Max
A	—	—	1.60
A1	0.05	—	0.15
A2	1.35	1.40	1.45
A3	0.59	0.64	0.69
b	0.18	—	0.26
b1	0.17	0.20	0.23
c	0.13	—	0.17
c1	0.12	0.13	0.14
D	15.80	16.00	16.20
D1	13.90	14.00	14.10
E	15.80	16.00	16.20
E1	13.90	14.00	14.10
e	—	0.50	—
eB	15.05	—	15.35
L	0.45	—	0.75
L1	—	1.00	—
θ	0°	—	7°

(Original dimensions are in millimeters)

Figure 5-8. LQFP100 recommended footprint



(Original dimensions are in millimeters)

5.5 LQFP64 package outline dimensions

Figure 5-9. LQFP64 package outline

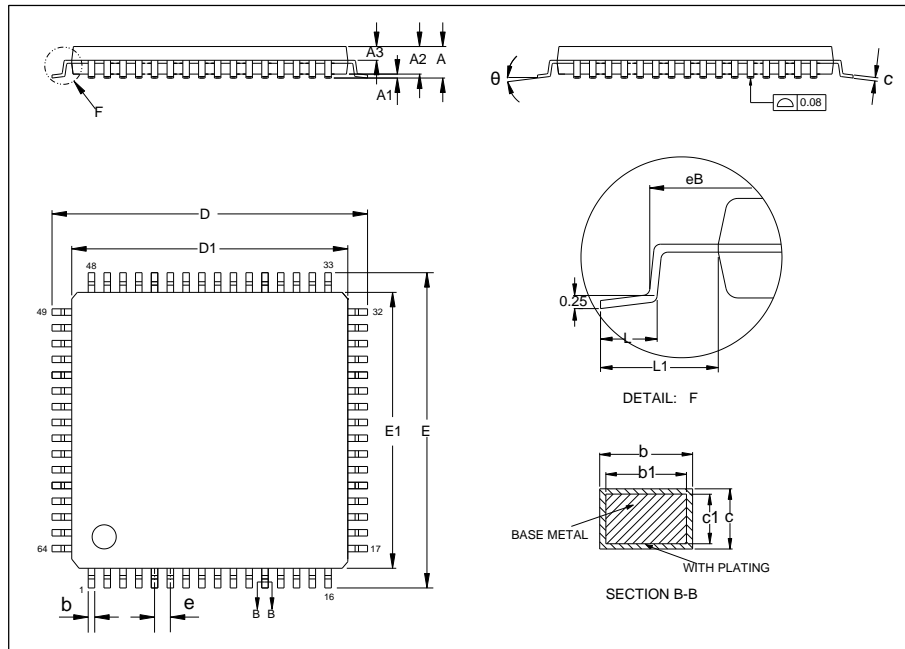
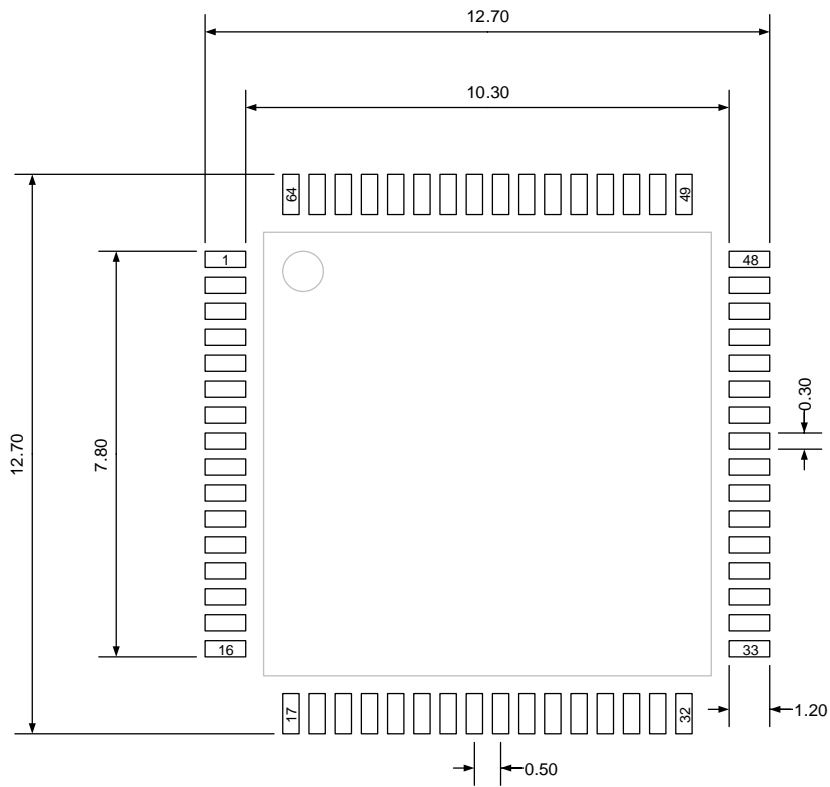

Table 5-5. LQFP64 package dimensions

Symbol	Min	Typ	Max
A	—	—	1.60
A1	0.05	—	0.15
A2	1.35	1.40	1.45
A3	0.59	0.64	0.69
b	0.18	—	0.26
b1	0.17	0.20	0.23
c	0.13	—	0.17
c1	0.12	0.13	0.14
D	11.80	12.00	12.20
D1	9.90	10.00	10.10
E	11.80	12.00	12.20
E1	9.90	10.00	10.10
e	—	0.50	—
eB	11.25	—	11.45
L	0.45	—	0.75
L1	—	1.00	—
θ	0°	—	7°

(Original dimensions are in millimeters)

Figure 5-10. LQFP64 recommended footprint



(Original dimensions are in millimeters)

5.6 Thermal characteristics

Thermal resistance is used to characterize the thermal performance of the package device, which is represented by the Greek letter “ θ ”. For semiconductor devices, thermal resistance represents the steady-state temperature rise of the chip junction due to the heat dissipated on the chip surface.

θ_{JA} : Thermal resistance, junction-to-ambient.

θ_{JB} : Thermal resistance, junction-to-board.

θ_{JC} : Thermal resistance, junction-to-case.

Ψ_{JB} : Thermal characterization parameter, junction-to-board.

Ψ_{JT} : Thermal characterization parameter, junction-to-top center.

$$\theta_{JA}=(T_J-T_A)/P_D \quad (5-1)$$

$$\theta_{JB}=(T_J-T_B)/P_D \quad (5-2)$$

$$\theta_{JC}=(T_J-T_C)/P_D \quad (5-3)$$

Where, T_J = Junction temperature.

T_A = Ambient temperature

T_B = Board temperature

T_C = Case temperature which is monitoring on package surface

P_D = Total power dissipation

θ_{JA} represents the resistance of the heat flows from the heating junction to ambient air. It is an indicator of package heat dissipation capability. Lower θ_{JA} can be considerate as better overall thermal performance. θ_{JA} is generally used to estimate junction temperature.

θ_{JB} is used to measure the heat flow resistance between the chip surface and the PCB board.

θ_{JC} represents the thermal resistance between the chip surface and the package top case. θ_{JC} is mainly used to estimate the heat dissipation of the system (using heat sink or other heat dissipation methods outside the device package).

Table 5-6. Package thermal characteristics⁽¹⁾

Symbol	Condition	Package	Value	Unit
θ_{JA}	Natural convection, 2S2P PCB	BGA176	45.02	°C/W
		LQFP144	48.76	
		BGA100	78.32	
		LQFP100	57.42	
		LQFP64	51.81	
θ_{JB}	Cold plate, 2S2P PCB	BGA176	26.55	°C/W
		LQFP144	35.00	

Symbol	Condition	Package	Value	Unit
		BGA100	55.27	
		LQFP100	31.68	
		LQFP64	33.36	
θ_{JC}	Cold plate, 2S2P PCB	BGA176	9.93	°C/W
		LQFP144	12.03	
		BGA100	20.15	
		LQFP100	13.85	
		LQFP64	11.25	
Ψ_{JB}	Natural convection, 2S2P PCB	BGA176	28.31	°C/W
		LQFP144	35.32	
		BGA100	55.74	
		LQFP100	41.28	
		LQFP64	33.53	
Ψ_{JT}	Natural convection, 2S2P PCB	BGA176	0.69	°C/W
		LQFP144	1.86	
		BGA100	1.74	
		LQFP100	0.75	
		LQFP64	0.49	

(1) Thermal characteristics are based on simulation, and meet JEDEC specification.

6. Ordering information

Table 6-1. Part ordering code for GD32F427xx devices

Ordering code	Flash (KB)	Package	Package type	Temperature operating range
GD32F427IKH6	3072	BGA176	Green	Industrial -40°C to +85°C
GD32F427IGH6	1024	BGA176	Green	Industrial -40°C to +85°C
GD32F427IEH6	512	BGA176	Green	Industrial -40°C to +85°C
GD32F427ZKT6	3072	LQFP144	Green	Industrial -40°C to +85°C
GD32F427ZGT6	1024	LQFP144	Green	Industrial -40°C to +85°C
GD32F427ZET6	512	LQFP144	Green	Industrial -40°C to +85°C
GD32F427VKH6	3072	BGA100	Green	Industrial -40°C to +85°C
GD32F427VGH6	1024	BGA100	Green	Industrial -40°C to +85°C
GD32F427VEH6	512	BGA100	Green	Industrial -40°C to +85°C
GD32F427VKT6	3072	LQFP100	Green	Industrial -40°C to +85°C
GD32F427VGT6	1024	LQFP100	Green	Industrial -40°C to +85°C
GD32F427VET6	512	LQFP100	Green	Industrial -40°C to +85°C
GD32F427RKT6	3072	LQFP64	Green	Industrial -40°C to +85°C
GD32F427RGT6	1024	LQFP64	Green	Industrial -40°C to +85°C
GD32F427RET6	512	LQFP64	Green	Industrial -40°C to +85°C

7. Revision history

Table 7-1. Revision history

Revision No.	Description	Date
1.0	Initial Release	Feb.22, 2022
1.1	<ol style="list-style-type: none"> 1. Add <u>Figure 4-4. Recommended PDR ON pin circuit</u> in chapter <u>4.5. Power supply supervisor characteristics</u>. 2. Add description of EMI in chapter <u>4.4. EMC characteristics</u>. 3. Modify the BGA100 and BGA64 footprint parameters in chapter <u>5. Package information</u>. 4. Modify the I2C timing parameters in <u>4.16. I2C characteristics</u>. 5. Modify f_{sck} maximum value in <u>Table 4 37. USART characteristics⁽¹⁾</u>. 6. Modify <u>Table 4 7. Power consumption characteristics⁽²⁾⁽³⁾⁽⁴⁾⁽⁵⁾</u>. 7. Modify the erase cycles in <u>Table 4 24. Flash memory characteristics</u>. 8. Modify the value of $V_{\text{ESD(HBM)}}$ and $V_{\text{ESD(CDM)}}$ in <u>Table 4 11. ESD characteristics⁽¹⁾</u>. 	May.24, 2022
1.2	<ol style="list-style-type: none"> 1. Update <u>Table 4-24. Flash memory characteristics</u>, <u>Table 4-34. I2C characteristics⁽¹⁾⁽²⁾</u>, <u>Table 4-37. USART characteristics⁽¹⁾</u>. 2. Update <u>Table 4-11. ESD characteristics⁽¹⁾</u> and <u>Figure 4-5. Recommended external NRST pin circuit⁽¹⁾</u>. 3. Update <u>Table 4-35. Standard SPI characteristics⁽¹⁾</u>. 	Jul.12, 2022
1.3	<ol style="list-style-type: none"> 1. Add notes for <u>Table 4-2. DC operating conditions</u> and <u>Table 4-7. Power consumption characteristics⁽²⁾⁽³⁾⁽⁴⁾⁽⁵⁾⁽⁶⁾</u>, and update <u>Table 4-7. Power consumption characteristics⁽²⁾⁽³⁾⁽⁴⁾⁽⁵⁾⁽⁶⁾</u>. 2. Update <u>Table 4-25. Flash memory characteristics⁽¹⁾</u>. 3. Add description of EMI and <u>Table 4-10. EMI characteristics⁽¹⁾</u>. 4. Update <u>Figure 4-7. I2C bus timing diagram</u>. 5. Update <u>Figure 4-26. I/O port DC characteristics⁽¹⁾⁽³⁾</u>. 	Jan.4, 2023

1.4	1. Add the <u>Table 4-44. Dynamics characteristics: Ethernet MAC signals for SMI⁽¹⁾</u> and <u>Figure 4-12. Ethernet SMI timing diagram</u> .	Mar.14, 2023
1.5	1. Updated <u>Table 2-4. GD32F4271x BGA176 pin definitions</u> , <u>Table 2-5. GD32F427Zx LQFP144 pin definitions</u> , <u>Table 2-6. GD32F427Vx LQFP100 pin definitions</u> , <u>Table 2-7. GD32F427Vx BGA100 pin definitions</u> , <u>Table 2-8. GD32F427Rx LQFP64 pin definitions</u> .	Jul.8, 2023
1.6	1. Modify the PE _{CYC} to 100 kcycles in <u>Table 4-24. Flash memory characteristics⁽¹⁾</u> . 2. Modify description note(3) of <u>Table 4-26. I/O port DC characteristics⁽¹⁾⁽³⁾</u> .	Dec.5, 2023
1.7	1. Add SRAM2 in <u>Figure 2-1. GD32F427xx block diagram</u> . 2. Delete EXMC SDRAM pin in GD32F427Vx. 3. Modify <u>Table 4-27. I/O port DC characteristics⁽¹⁾⁽³⁾</u> . 4. Modify <u>Figure 5-1. LQFP144 package outline</u> , <u>Figure 5-5. LQFP100 package outline</u> and <u>Figure 5-7. LQFP64 package outline</u> .	Jul.15, 2024
1.8	1. Update the note on VREFP power up timing in <u>Table 4-28. ADC characteristic</u> . 2. Modify DAC to DAC0 in chapter <u>2. Device-overview</u> . 3. Update the parameters f _{PLLOUT} and f _{VCO} in <u>Table 4-20. PLL characteristic</u> , <u>Table 4-21. PLLI2S characteristic</u> and <u>Table 4-22. PLLSAI characteristic</u> . 4. Update <u>Figure 4-4. Recommended PDR ON pin circuit</u> and note. 5. Update description in chapter <u>3.13. Serial peripheral interface</u> and <u>3.14 Universal synchronous/asynchronous receiver transmitter (USART/UART)</u> . 6. Update the description of t _h (DATA) in <u>Table 4-54. DCI characteristics⁽¹⁾</u> .	Dec.25, 2024

Important Notice

This document is the property of GigaDevice Semiconductor Inc. and its subsidiaries (the "Company"). This document, including any product of the Company described in this document (the "Product"), is owned by the Company under the intellectual property laws and treaties of the People's Republic of China and other jurisdictions worldwide. The Company reserves all rights under such laws and treaties and does not grant any license under its patents, copyrights, trademarks, or other intellectual property rights. The names and brands of third party referred thereto (if any) are the property of their respective owner and referred to for identification purposes only.

The Company makes no warranty of any kind, express or implied, with regard to this document or any Product, including, but not limited to, the implied warranties of merchantability and fitness for a particular purpose. The Company does not assume any liability arising out of the application or use of any Product described in this document. Any information provided in this document is provided only for reference purposes. It is the responsibility of the user of this document to properly design, program, and test the functionality and safety of any application made of this information and any resulting product. Except for customized products which has been expressly identified in the applicable agreement, the Products are designed, developed, and/or manufactured for ordinary business, industrial, personal, and/or household applications only. The Products are not designed, intended, or authorized for use as components in systems designed or intended for the operation of weapons, weapons systems, nuclear installations, atomic energy control instruments, combustion control instruments, airplane or spaceship instruments, transportation instruments, traffic signal instruments, life-support devices or systems, other medical devices or systems (including resuscitation equipment and surgical implants), pollution control or hazardous substances management, or other uses where the failure of the device or Product could cause personal injury, death, property or environmental damage ("Unintended Uses"). Customers shall take any and all actions to ensure using and selling the Products in accordance with the applicable laws and regulations. The Company is not liable, in whole or in part, and customers shall and hereby do release the Company as well as its suppliers and/or distributors from any claim, damage, or other liability arising from or related to all Unintended Uses of the Products. Customers shall indemnify and hold the Company as well as its suppliers and/or distributors harmless from and against all claims, costs, damages, and other liabilities, including claims for personal injury or death, arising from or related to any Unintended Uses of the Products.

Information in this document is provided solely in connection with the Products. The Company reserves the right to make changes, corrections, modifications or improvements to this document and Products and services described herein at any time, without notice.