

GigaDevice Semiconductor Inc.

**GD32 MCU Power Consumption
Testing Process**

**Application Note
AN105**

Table of Contents

Table of Contents	1
List of Figures	2
List of Tables	3
1. Introduction.....	4
2. Power consumption testing process.....	5
2.1. Preparation of test tools	5
2.2. Power consumption testing setting	5
2.3. Testing process	6
2.4. General Problems.....	7
2.5. Case description	8
3. Summary	9
4. Revision history.....	10

List of Figures

Figure 2-1. Schematic diagram of hardware connection for test.....	6
Figure 2-2. Hardware cable connections for Battery supply test	7
Figure 2-3. Power consumption characteristic.....	8

List of Tables

Table 4-1. Revision history 10

1. Introduction

This article is designed for GD32 MCU, mainly introduces the power testing process, including the selection and use of test instrument specifications, hardware circuit design, software code use, test data recording, so as to achieve accurate power data.

2. Power consumption testing process

2.1. Preparation of test tools

MCU power consumption testing generally requires the following tools:

1. MCU chip to be tested. In general, at least three samples of the same batch and process of MCU should be taken as the tested objects. After getting the chip, check whether the silk screen is clear on the surface of the chip package, and the pin is clean and has no sign of bending damage.
2. Minimum system board, only the power supply, crystal input pin, reset, download port, BOOT pin, to avoid the influence of external excess circuit current consumption.
3. Multimeter used to measure the input current of the MCU under test. A multimeter with at least four and a half digits should be used. If possible, a multimeter with a higher digit should be used to ensure accurate and reliable test data. During the test, connect the pen of the multimeter in the way of current measurement and set the gear to DC current.
4. Signal source used to provide an external active clock for the MCU under test under some test requirements. The recommended signal source is an instrument with a frequency of 30MHz, a resolution of 16 bits, and a sampling rate of 250MSa / s or higher.
5. Dc digital power supply, according to test requirements to adjust the output use.
6. J-Link, use to test code download.

2.2. Power consumption testing setting

Hardware configuration

According to the comprehensive consideration of user performance and power consumption, refer to the chapter of clock tree in user manual and power consumption with datasheet, select the appropriate power supply voltage and crystal oscillator input, and configure the clock source as the required master frequency by operating the frequency divider and frequency multiplier to set the clock source to the desired primary frequency.

Select an appropriate stabilizing voltage source according to the specific product, and adjust the voltage value to 3.3V / 5V. Most of the products use 3.3V power supply, some of the car gauge chips use 5V power supply compatible with 3.3V. The crystal oscillator input supports passive crystal oscillator and active crystal oscillator. Select the appropriate crystal oscillator by referring to the crystal oscillator input range specified in the clock tree of the user manual of the chip. When the external crystal does not meet the test conditions, the signal source can be used as the HXTAL input to facilitate the test, and the MCU enables BYPASS MODE. Signal source output requirements: high resistance output, square wave, duty cycle 50%,

frequency 4MHz / 2MHz, VPP=3.3V, OFFSET=1.65V.

Software configuration

Peripheral enabled / disabled. The software developer turns on / off the relevant peripheral clock by manipulating library functions in the code according to the user manual.

I / O port configuration. Before entering low power mode, all spare I / O pins need to be configured as analog inputs. It should be noted that the minimum package is configured as the maximum package pins, even if these pins are not drawn in the package. Before configuring pins, you are advised to add a wait time to the code to prevent the debugging port from being disabled.

Low power mode selection. Select the required low power mode according to the configuration code in the power consumption section of the datasheet. After entering the low power mode, the power consumption is close to that of the datasheet.

2.3. Testing process

The hardware and software test conditions of each mode are different. After understanding the basic requirements of each mode, you can perform the test in the following sequence to simplify the process, save time and cost, and reduce the loss of hardware insertion and removal.

Build hardware framework

Select appropriate power supply, external crystal / signal source, and configure BOOT pins to form the MCU minimum system. The actual power consumption of "I_{VDD}+I_{VDDA}" under different power consumption modes can be tested by connecting the ammeter in series in the minimum system of power supply and MCU according to the power consumption section of the datasheet, as shown in [Figure 2-1. Schematic diagram of hardware connection for test.](#)

Figure 2-1. Schematic diagram of hardware connection for test

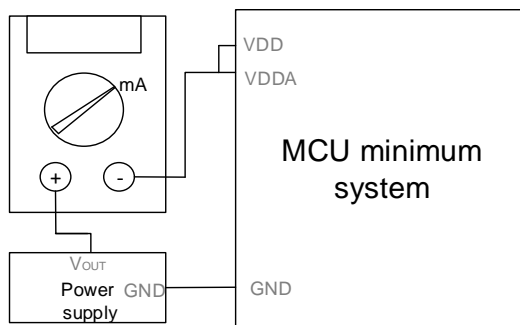

As shown in [Figure 2-2. Hardware cable connections for Battery supply test](#), when MCU VDD is disconnected, its VBAT pin can be connected to backup source power supply such as battery or other power supply. MCU Battery supply has four modes: LXTAL High driving, LXTAL Medium High driving, LXTAL Medium Low driving, LXTAL Low driving. The test is to

GD32 MCU Power Consumption Testing Process

separately test the input current of the VBAT pin in each mode of Battery supply when the MCU VDD is disconnected. Generally, the common VBAT supply voltage is 3.6V, 3.3V, 2.6V, 1.8V. According to the four modes, it is divided into four codes. Each code is directly compiled and downloaded, and tested and recorded by changing different power supply voltages.

Figure 2-2. Hardware cable connections for Battery supply test

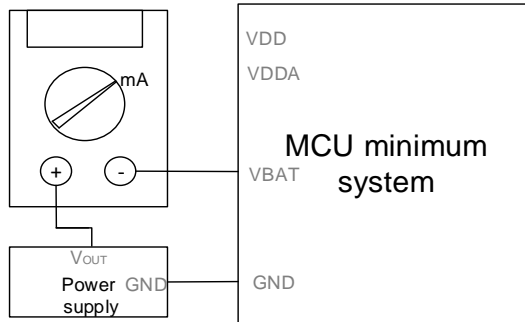

Download code

The test is generally configured by the software writer, and the code is written according to the requirements of the corresponding power mode in the data manual. If there are special values of clock frequency and power supply voltage, the test conditions need to be set separately. Download the code into MCU.

Power consumption reading

Separate the minimum system board from the debugging tool. Turn off and restart the power supply to generate a power-on reset and disable the internal debug circuit. Test the corresponding power consumption and wait for the ammeter to stabilize before recording data.

2.4. General Problems

Code download exception

"No Cortex-M SW Device Found" is displayed. Check whether all the connections are correct and whether there is bad contact; Check that the download port is configured to Analog input. If the first download is normal and the second download is abnormal, check whether the system clock Settings and waiting time are correct. If the Settings are not correct, the download port will be configured as an analog input mode after the program is downloaded for the first time, making the MCU no longer recognized and unable to perform subsequent downloads. At this point, we need to put MCU into ISP mode and erase flash. Reset the code and download.

The message "Cannot Load Flash Device Description" is displayed. Check whether the Options for Target of Keil has installed the PACK package and whether the MCU model is selected; All wiring is correct, there is no forget jumper, poor contact and other situations.

The message "Cannot Load Flash Programing Algorithm" is displayed. Whether the correct

Flash Size is added to Programming Algorithm in the Debug-Flash Download and whether the RAM for Algorithm is set correctly.

Data deviation

Each test will have a reference value. When the measurement contrast deviation is large, the following checks can be done: Check whether the hardware test system is connected to other wire paths, resulting in system leakage; It is necessary to identify the source of reference values to determine whether power consumption differences are caused by power consumption reduction or function adjustment and improvement. Determine if the code is written to meet the power test requirements, such as whether the GPIO is configured to analog input state, whether all peripherals are enabled or disabled, whether the register is configured successfully, and whether the system clock is configured correctly; Check whether the system clock is set correctly. You can first check whether the code parameters are correctly configured, and then use PA8 to output the system clock and use oscilloscope to observe the running clock frequency.

2.5. Case description

Take GD32F303 series as an example, as shown in [Figure 2-3. Power consumption characteristic](#). power consumption characteristics are configured according to the test conditions in the datasheet. Under DeepSleep mode, MCU is selected to supply 3.3V power, external crystal oscillator is selected as 8MHz passive crystal oscillator, system clock is set as 120MHz, and LDO is set in lower power mode. Turn off IRC40K, turn off RTC, and configure all GPIOs in analog input mode. At 25°C, the DeepSleep mode power range of the minimum system on the chip should be between 159.8uA and 1100uA.

Figure 2-3. Power consumption characteristic

Symbol	Parameter	Conditions	Typ ⁽¹⁾		Max	Unit
			T _A = 25°C	T _A = 85°C	T _A = 25°C	
		V _{DD} = V _{DDA} = 3.3 V, HXTAL = 8 MHz, System Clock = 8 MHz, CPU clock off, All peripherals disabled	2.2	3.4	—	mA
	Supply current (Deep-Sleep mode)	V _{DD} = V _{DDA} = 3.3 V, LDO in run mode, IRC40K off, RTC off, All GPIOs analog mode	189.5	1159.3	1100	μA
		V _{DD} = V _{DDA} = 3.3 V, LDO in low power mode, IRC40K off, RTC off, All GPIOs analog mode	159.8	1124.0	1100	μA
		V _{DD} = V _{DDA} = 3.3 V, Main LDO in under drive mode, IRC40K off, RTC off, All GPIOs analog mode	162.8	944.0	1100	μA
		V _{DD} = V _{DDA} = 3.3 V, Low Power LDO in under drive mode, IRC40K off, RTC off, All GPIOs analog mode	133.0	910.3	1100	μA

3. Summary

According to the measured application time and current consumption of each MCU mode, the average current consumption can be estimated in the actual application program, so that users can calculate the sustainable working time of MCU under the condition of battery power. In general, the test result under the standard testing process is close to the value of the datasheet, but considering the individual difference of the chip and the update of the chip version, the actual data may be inconsistent with the datasheet.

4. Revision history

Table 4-1. Revision history

Revision No.	Description	Date
1.0	Initial Release	Apr.7, 2023

Important Notice

This document is the property of GigaDevice Semiconductor Inc. and its subsidiaries (the "Company"). This document, including any product of the Company described in this document (the "Product"), is owned by the Company under the intellectual property laws and treaties of the People's Republic of China and other jurisdictions worldwide. The Company reserves all rights under such laws and treaties and does not grant any license under its patents, copyrights, trademarks, or other intellectual property rights. The names and brands of third party referred thereto (if any) are the property of their respective owner and referred to for identification purposes only.

The Company makes no warranty of any kind, express or implied, with regard to this document or any Product, including, but not limited to, the implied warranties of merchantability and fitness for a particular purpose. The Company does not assume any liability arising out of the application or use of any Product described in this document. Any information provided in this document is provided only for reference purposes. It is the responsibility of the user of this document to properly design, program, and test the functionality and safety of any application made of this information and any resulting product. Except for customized products which has been expressly identified in the applicable agreement, the Products are designed, developed, and/or manufactured for ordinary business, industrial, personal, and/or household applications only. The Products are not designed, intended, or authorized for use as components in systems designed or intended for the operation of weapons, weapons systems, nuclear installations, atomic energy control instruments, combustion control instruments, airplane or spaceship instruments, transportation instruments, traffic signal instruments, life-support devices or systems, other medical devices or systems (including resuscitation equipment and surgical implants), pollution control or hazardous substances management, or other uses where the failure of the device or Product could cause personal injury, death, property or environmental damage ("Unintended Uses"). Customers shall take any and all actions to ensure using and selling the Products in accordance with the applicable laws and regulations. The Company is not liable, in whole or in part, and customers shall and hereby do release the Company as well as its suppliers and/or distributors from any claim, damage, or other liability arising from or related to all Unintended Uses of the Products. Customers shall indemnify and hold the Company as well as its suppliers and/or distributors harmless from and against all claims, costs, damages, and other liabilities, including claims for personal injury or death, arising from or related to any Unintended Uses of the Products.

Information in this document is provided solely in connection with the Products. The Company reserves the right to make changes, corrections, modifications or improvements to this document and Products and services described herein at any time, without notice.