

GigaDevice Semiconductor Inc.

**Testing Guidelines for RF Performance and
Transceiver Power Consumption of
GD32VW553**

Application Note

AN149

Revision 1.2

(Jul.2024)



Table of Contents

Table of Contents	1
List of Figures	3
List of Tables	4
1. Introduction	5
2. Test preparation	6
2.1. System building	6
2.2. Hardware configuration	6
2.3. Software configuration	8
3. RF Test - use RF tool	10
3.1. Introduction to tools	10
3.2. Test mode setting	11
3.3. WiFi discontinuous packet sending test	11
3.4. WiFi continuous packet sending test	12
3.5. WiFi single carrier transmitting test	13
3.6. WiFi receiving test	14
3.7. BLE discontinuous packet sending test	15
3.8. BLE continuous packet sending test	16
3.9. BLE single carrier transmitting test	17
3.10. BLE Receiving test	17
3.11. Temperature display	18
4. RF Test - use serial port commands	19
4.1. Serial port connection	19
4.2. Test Mode setting	20
4.3. WiFi discontinuous packet sending test	20
4.4. WiFi continuous packet sending test	22
4.5. WiFi single carrier transmitting test	22
4.6. WiFi receiving test	23
4.7. BLE discontinuous packet sending test	24
4.8. BLE continuous packet sending test	25



4.9. BLE single carrier transmitting test	25
4.10. BLE Receiving test	26
4.11. Temperature display	26
5. Power consumption test	27
5.1. Test preparation	27
5.2. Transmitting power consumption test	28
5.3. Receiving power consumption test	29
6. FAQ	30
7. Revision history	31



List of Figures

Figure 2-1. RF test system.....	6
Figure 2-2. Reference connection of GD development board	8
Figure 2-3. Installation of serial port drive.....	9
Figure 2-4. GDLINK folder	9
Figure 3-1. Description of tool functions	10
Figure 3-2. Packet TX Tool setting	12
Figure 3-3. Continuous TX Tool setting	13
Figure 3-4. LO TX Tool setting	14
Figure 3-5. Packet RX Tool setting	15
Figure 3-6. BLE TX Tool setting	16
Figure 3-7. BLE Test TX Infinite Tool setting	16
Figure 3-8. BLE LO TX TOOL setting.....	17
Figure 3-9. Description of BLE receiving test commands	18
Figure 3-10. Temperature display	18
Figure 4-1. GD serial port tool.....	19
Figure 4-2. Serial port boot information.....	20
Figure 4-3. Description of Packet Tx test commands	21
Figure 4-4. Description of frequency offset correction commands	22
Figure 4-5. Description of Continuous Tx test commands	22
Figure 4-6. Description of LO Tx test commands	23
Figure 4-7. Description of Packet Rx test commands	24
Figure 4-8. Description of commands for BLE discontinuous packet sending test	24
Figure 4-9. Description of commands for BLE continuous packet sending test	25
Figure 4-10. Description of commands for BLE LO Tx test	25
Figure 4-11. Description of BLE receiving test commands	26
Figure 4-12. Description of temperature display commands	26
Figure 5-1. Power consumption test system.....	28
Figure 5-2. Tx power consumption test	28
Figure 5-3. Rx power consumption test.....	29



List of Tables

Table 3-1. Test modes	11
Table 4-1. Correspondence between rate and index	20
Table 4-2. CMD ble_test_tx parameter description	24
Table 4-3. CMD ble_test_rx parameter description	26
Table 7-1. Revision history	31



1. Introduction

This document is mainly used to give instructions to clients to test various RF parameters and corresponding power consumption of transmitting and receiving of the WiFi and BLE development board corresponding to the chips of GD32VW553 series in non-signaling mode. Chapter 2 introduces configuration of test systems, software and hardware of the development board. Chapter 3 introduces test methods of RF parameters with GD RF test tool. Chapter 4 introduces test methods of RF parameters with serial port commands. Chapter 5 introduces test methods of RF transmitting and receiving power consumption in non-signaling mode. Chapter 6 is about frequently-asked questions and corresponding solutions. Chapter 7 is version history.

2. Test preparation

This chapter introduces the preparations for RF test, including the building of the test system and software and hardware platforms, and the hardware configuration section includes the instructions for configuration of the GD development board (module).

2.1. System building

The RF (radio frequency) test system mainly includes three parts: PC, device under test (DUT), and RF test instrument [Figure 2-1. RF test system](#):

1. The RF port of the wireless test instrument (such as itenest WT328) is connected to the DUT RF test socket by using an RF cable.
2. PC controls DUT and the instrument through UART (USB to UART) and Ethernet respectively, and tests transmitted (Tx) and received (Rx) RF parameters of DUT.

Figure 2-1. RF test system

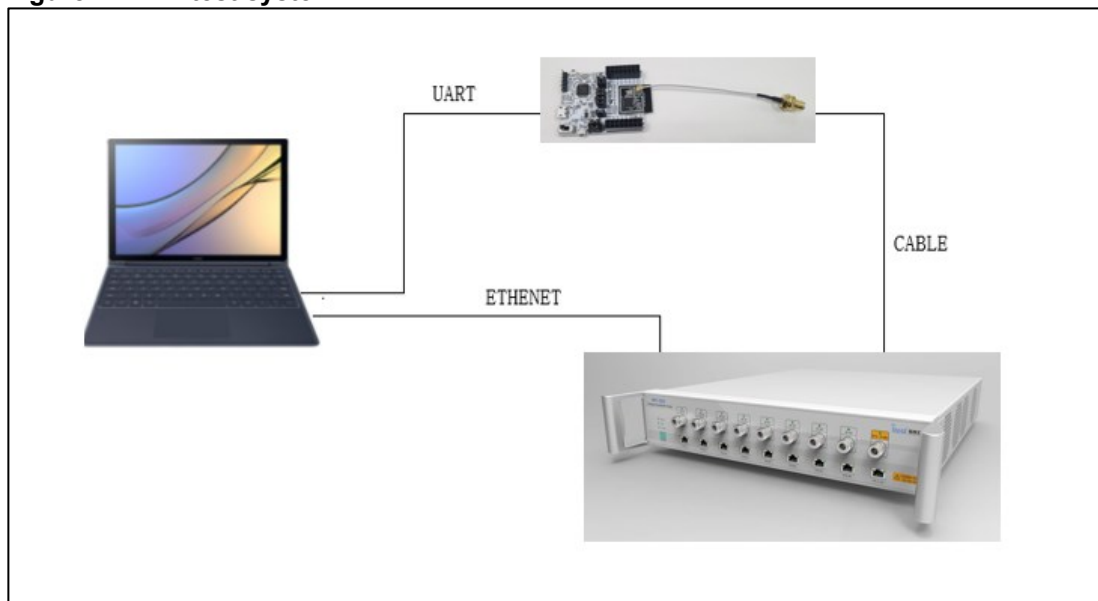

2.2. Hardware configuration

For GD “Start” development board ([Figure 2-2. Reference connection of GD development board](#), mother board + module), Version 1.0 Start board use DAPLINK circuit as the communication circuit while Version 3.0 use GDLINK circuit. Below description is mainly based on Version 3.0 Start board.

1. UART & JLINK functions: The communication function of USB to UART and the firmware burning function of USB to JLINK are realized through the GDLINK circuit on the development board, and PC is connected to the USB port of the mother board through a USB cable;

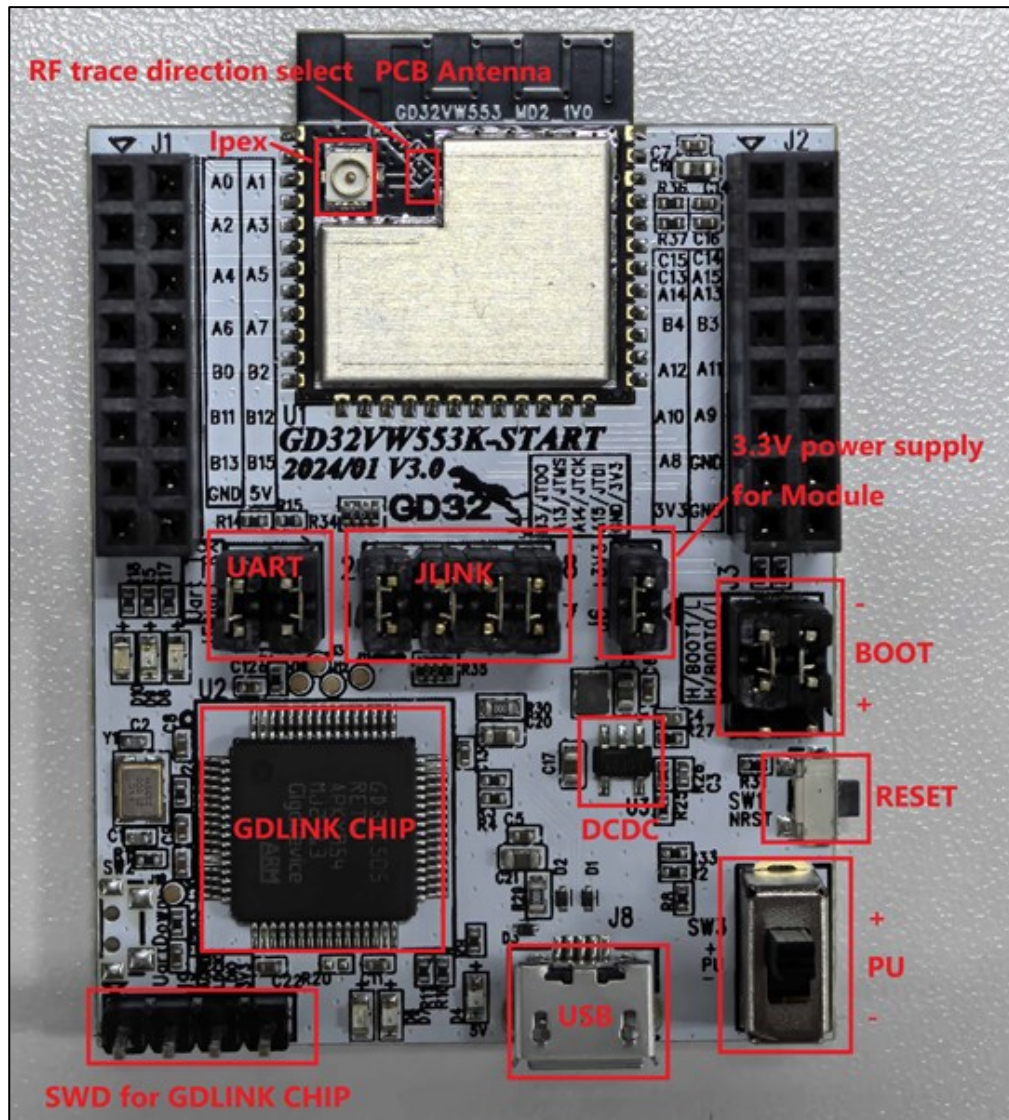

2. Serial port connection: Serial ports are connected to the mother board J5.2/4 (main chip UART PIN) and J5.1/3 (GDLINK UART PIN)) respectively with jumpers.
3. JLINK connection: JLINK are connected to the mother board J4.2/4/6/8 (main chip JLINK PIN) and J4.1/3/5/7 (GDLINK JLINK PIN)) respectively with jumpers.
4. Configuration of the main chip mode:
 - "BOOT0" of PIN should be at low level (boot from flash), which is realized through connection to mother board J3.3 and J3.5.
 - "PU" of PIN should be at high level, which is realized by "lifting" the switch "SW3" on the mother board.
5. Module antenna switching:
 - Switch the position of the resistor by welding [Figure 2-2. Reference connection of GD development board](#) to select the RF signal path of DUT: When the left side of the resistor faces upward, the RF path leads to the PCB antenna and can only be used for radiation test; when the left side of the resistor faces downward, the RF path leads to the RF (Iplex) connector and is used for conduction test or radiation test of external antenna. This document mainly targets on **conduction test**.
 - Connect the RF test socket of DUT and the RF port of the instrument with the Iplex to SMA cable.
6. Module power supply: The DCDC circuit on the mother board converts the 5V power input from the USB port into a 3V3 output, and the 3V3 output is connected to the 3V3 pad of the module through the jumper cap "J6". Disconnect this jumper (from external 3V3 output to J6.2) to test power consumption of the module.

GigaDevice **Figure 2-2. Reference connection of GD development board**

2.3. Software configuration

1. Drive installation: After the development board hardware and the test system are built, connect the two ends of the USB cable to the development board and PC respectively. For GDLINK, no driver is needed for WIN10 system but a corresponding driver should be installed for WIN7 system. For DAPLINK, Firstly install the DAPLINK drive "mbedWinSerial_16466.rar" on PC: After decompression, double-click the .exe file to start automatic installation. After installation, the serial port device and COM number [Figure 2-3. Installation of serial port driver](#) are displayed in the "Device Manager" on PC. It is recommended to install Windows 10/Windows 7 system on PC.

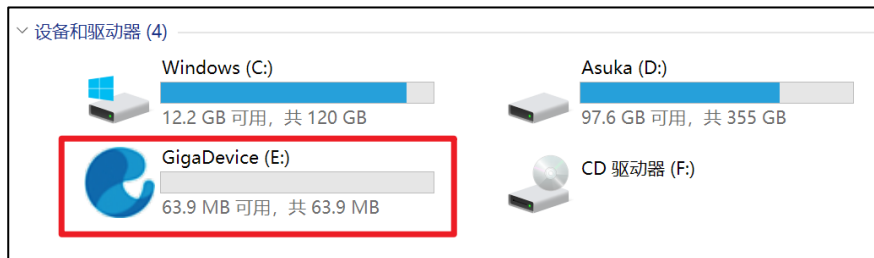

Figure 2-3. Installation of serial port driver



2. Firmware download: After the GDLINK drive is installed, a new diskette named "GigaDevice" [Figure 2-4. GDLINK folder](#) is displayed in the path of PC-"Explorer". Directly "drag and drop" (or copy and paste) the test firmware named "rf_test" to this drive letter, wait for a while to achieve firmware burning, and click **Reset** to restart the chip.

Figure 2-4. GDLINK folder





3. RF Test - use RF tool

This chapter introduces how to test transmitted and received RF parameters in non-signaling mode with the GD RF test tools.

3.1. Introduction to tools

[Figure 3-1. Description of tool functions](#) shows the interface and functions of the first opened RF test tool "GD RF Test Tool" provided by GD (serial port not connected and chip not initialized).

Figure 3-1. Description of tool functions

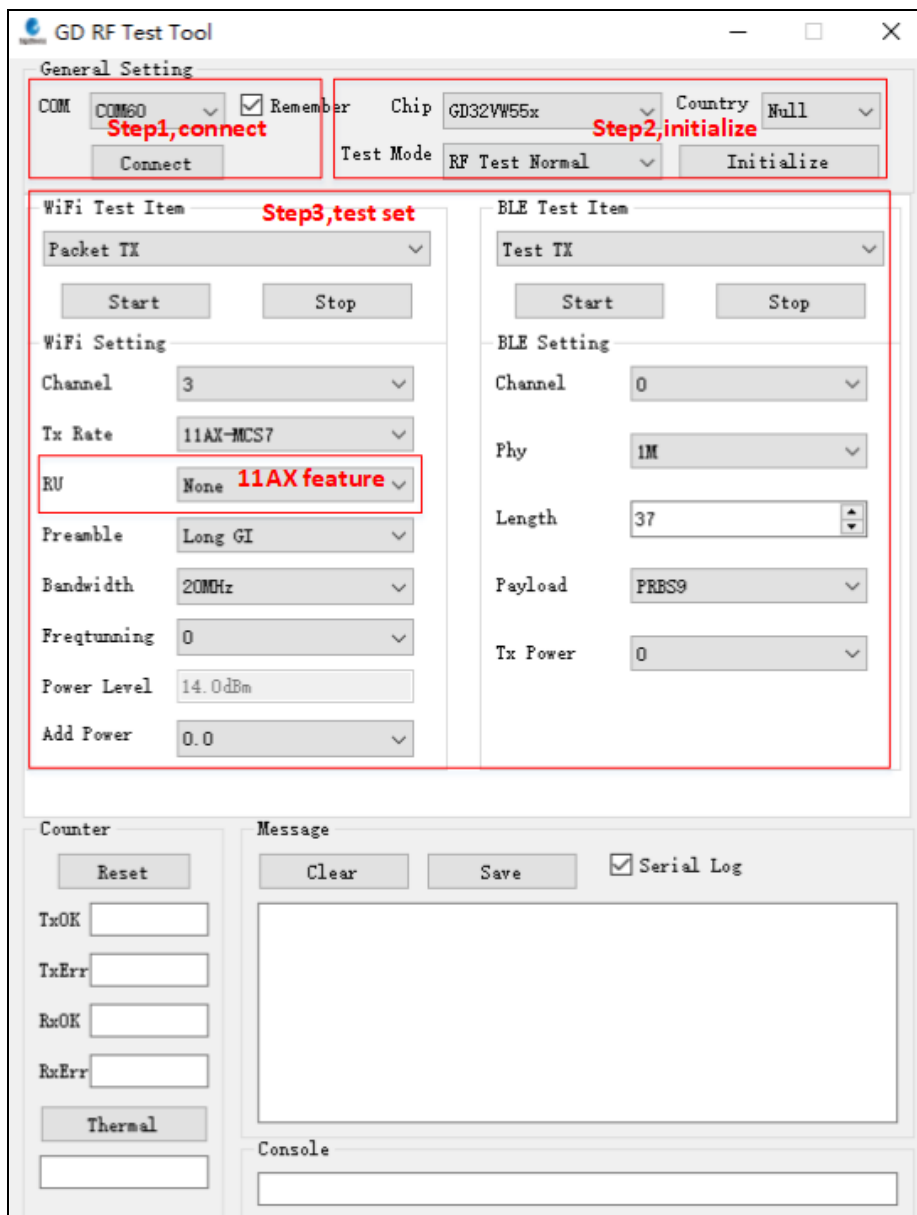



3.2. Test mode setting

1. Serial port connection: Select the serial port number of DUT in the drop-down menu of **COM** on the tool interface, click **Connect**, and the text displayed on the button changes to **Disconnect**, which indicates that the serial port is successfully connected, and the **Freq-tuning** bar displays the calibrated value. If the serial port connection fails, the log window will report the error.
2. Mode setting: There are three test modes according to [Table 3-1. Test modes](#), and the default mode is **RF Test Normal**. Click **Initialize**, and the text displayed on the button changes to **De-initialize**, which indicates that you enter the RF Test Normal mode.
3. If the development board is restarted or replaced with another development board for test, repeat the step 1 and 2. If "**Disconnect**" and "**De-initialize**" are displayed, click the buttons twice in succession to connect the serial port and initialize the chip mode again.

Table 3-1. Test modes

Test mode	Description	RF calibration compensation value	Temperature compensation mechanism
MP mode	For RF calibration test (for PCBs whose RF is un-calibrated/needs to be recalibrated)	Disabled	Disabled
RF Test Normal	For RF test at normal temperature (for PCBs whose RF is calibrated)	Enabled	Disabled
RF Test Temp	For RF test at high and low temperatures (for PCBs whose RF is calibrated)	Enabled	Enabled

3.3. WiFi discontinuous packet sending test

This test item is defined as the modulated signal Tx with 10% duty, which is used to test protocol parameters, such as Tx power, EVM, and frequency offset.

1. DUT terminal setting: On the tool interface, set **WiFi Test Item** to **Packet TX**, set **Channel**, and **Tx Rate**, click **Start**, and the chip starts to transmit the Tx RF signal.
2. Demodulation setting on the instrument: Refer to Point 1 to set **Channel**, **Test Mode**, and **Power Level** on the instrument, and start the test.
3. Tx adjustment: To modify the power, first click "**Stop**" to stop Tx, modify the value in "**Add Power**" in a step unit of 0.25 db, and click "**Start**". At this time, refer to the following formula for the expected power:

Expected power = default power ("**power level**" value) + power adjustment value ("**Add Power**" value)

To modify the frequency offset, you can adjust **Freqtuning** at the same time. If the frequency offset is a positive value, this value needs to be increased; otherwise, this value



needs to be decreased. The value can be adjusted during the Tx process.

4. Temperature test (if necessary): Select **RF Test Temp** and reinitialize, and repeat Steps 1-3. Please note that the temperature compensation mechanism can take effect only after the Tx is stopped and restarted at different environment temperatures.

As shown in [Figure 3-2. Packet TX Tool setting](#), set **Channel** to 3 (2,422 MHz), **Tx Rate** to 11AX MCS7, and **Power Level** to 14 dBm, and start **Packet TX**.

Figure 3-2. Packet TX Tool setting

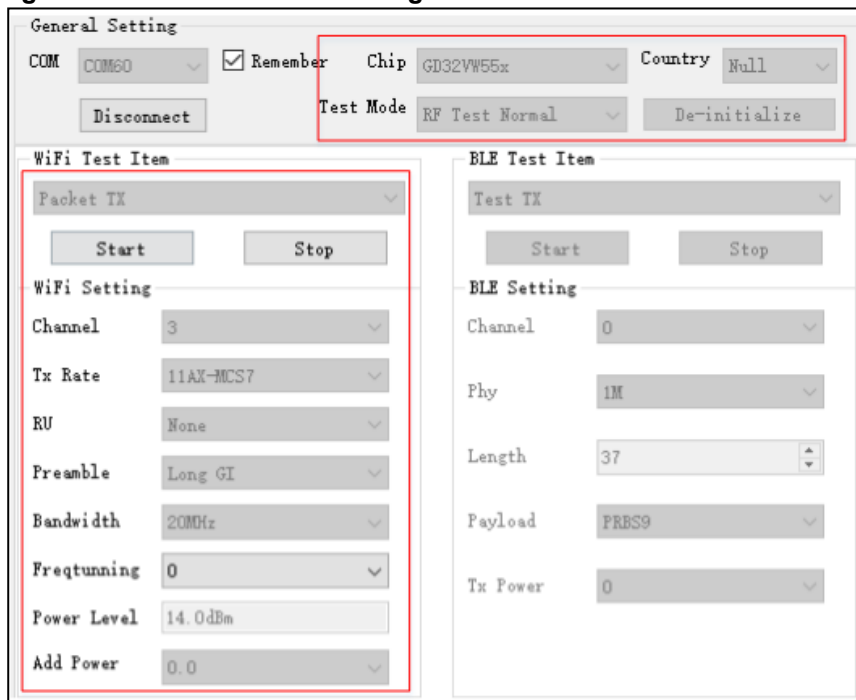

3.4. WiFi continuous packet sending test

This test item is defined as the modulated signal Tx with 100% duty, which is used to test the transmitted spectrum waveform, harmonic characteristics, etc. The method is similar with [Section 3.3](#), while the difference is that **WiFi Test Item** needs to be set to **Continuous TX**.

As shown in [Figure 3-3. Continuous TX Tool setting](#), set **Channel** to 1 (2,412 MHz), **Tx Rate** to 11G 6M, and **Power Level** to 17 dBm, and start **Continuous TX**.



Figure 3-3. Continuous TX Tool setting

3.5. WiFi single carrier transmitting test

This test item is defined as the single carrier Tx in WiFi mode, which is used to test the frequency offset and other parameters. The method is similar with [WiFi discontinuous packet sending test](#), while the difference is that **WiFi Test Item** needs to be set to **LO TX**, and only **Channel** needs to be set for other parts. The **Power Level** of this test item cannot be adjusted.

As shown in [Figure 3-4. LO TX Tool setting](#), set **Channel** to 7 (2,442 MHz) and start **LO TX**, and the single carrier signal is displayed in the spectrometer.

Figure 3-4. LO TX Tool setting

3.6. WiFi receiving test

This test item is used to test the received packet error rate (RX PER), receiving sensitivity, and other parameters in a **shielded room environment** without any interference.

1. Set "WiFi Test Item" to "Packet RX" and set "Channel" and "Bandwidth".
2. Click "Start" and "Reset" to reset the counter.
3. At this time, the instrument has not sent any packet. Observe the numbers shown in RxOK and RxErr at the lower left corner of the interface for a few seconds to confirm that they are always empty, which indicates that the environment is "clean", and then set the packet sending of the instrument.
4. After the instrument has sent packets, record the result of the counter (number of RxOK packets) on the interface, and calculate PER according to the following formula: $PER = (\text{number of packets sent by the instrument} - \text{RxOK}) / \text{number of packets sent by the instrument}$ (WiFi protocol specifies that 11b rate PER should be no higher than 8% and 11g/n/ax rate PER should be no higher than 10%).
5. If retesting is required, repeat step 2 to step 4.

For the waveform of the instrument used for testing RX, the recommended values are generally as follows: The packet length is 1024 Bytes and number of packets is 1000.

As shown in [Figure 3-5. Packet RX Tool setting](#), it means that when Channel = 1 (2422 MHz), rate= 11G 6M, number of packets sent = 1000, and interface **RxOK** counter = 938, then $PER = (1000 - 927) / 1000 = 7.3\%$ (< 10%), which indicates that the test passes.

Figure 3-5. Packet RX Tool setting

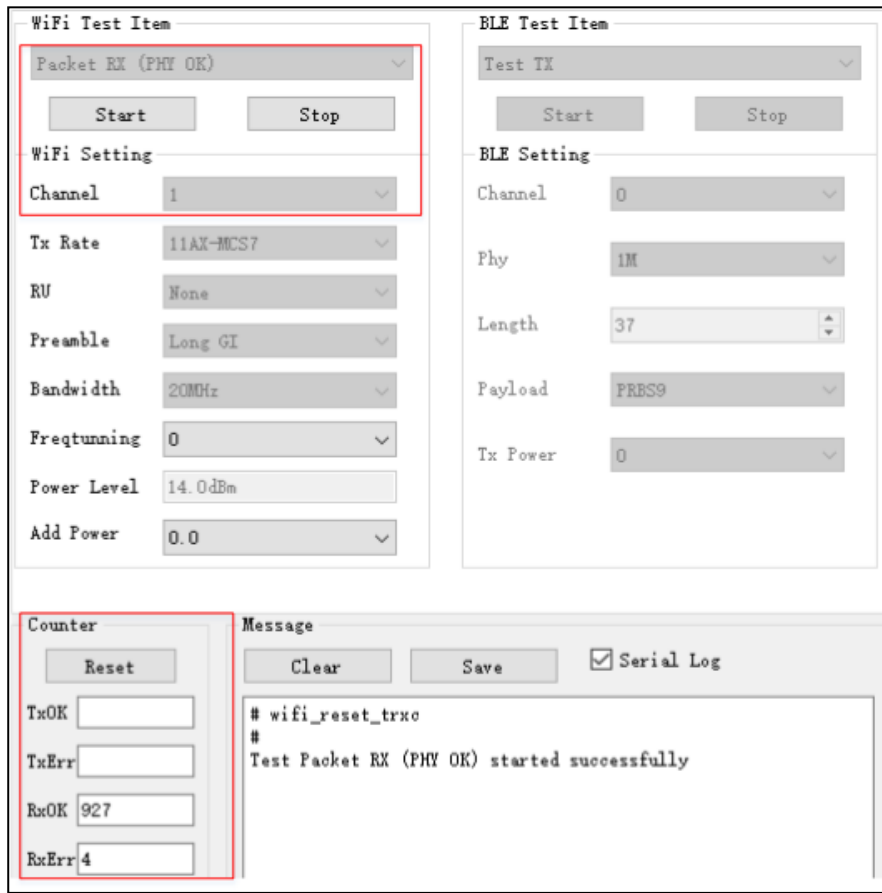

3.7. BLE discontinuous packet sending test

This test item is defined as the modulated signal Tx, which is used to test protocol parameters, such as Tx power, modulation index, and frequency offset.

1. Set "BLE Test Item" to "Test TX". Set "Channel", "Phy", "Length", "Payload", and "TX Power". Click "Start".
2. Set parameters on the instrument according to Point 1 and start the test.
3. Click "Stop" to end the test.

As shown in [Figure 3-6. BLE TX Tool setting](#), set **Channel** to 0 (2,402 MHz), **Phy** to 1M, **Payload** to "11110000", **Tx Power** to 0 dBm, and start **Test TX**.

Figure 3-6. BLE TX Tool setting

<p>WiFi Test Item</p> <p>Packet RX (PHY OK) <input type="button" value="Start"/> <input type="button" value="Stop"/></p> <p>WiFi Setting</p> <p>Channel: 1</p> <p>Tx Rate: 11AX-MCS7</p> <p>RU: None</p> <p>Preamble: Long GI</p> <p>Bandwidth: 20MHz</p> <p>Freqtunning: 0</p> <p>Power Level: 14.0dBm</p> <p>Add Power: 0.0</p>	<p>BLE Test Item</p> <p>Test TX <input type="button" value="Start"/> <input type="button" value="Stop"/></p> <p>BLE Setting</p> <p>Channel: 0</p> <p>Phy: 1M</p> <p>Length: 37</p> <p>Payload: 11110000</p> <p>Tx Power: 0</p>
---	--

3.8. BLE continuous packet sending test

This test item is defined as the modulated signal Tx with 100% duty, which is used to test the transmitted spectrum waveform, harmonic characteristics, etc. The method is similar with [BLE discontinuous packet sending test](#), while the difference is that **BLE Test Item** needs to be set to **Test TX Infinite**.

As shown in [Figure 3-7. BLE Test TX Infinite Tool setting](#), set **Channel** to 19 (2,440 MHz), **Phy** to 2M, **Payload** to "PRBS9", **Tx Power** to 5 dBm, and start **Test TX Infinite**.

Figure 3-7. BLE Test TX Infinite Tool setting

<p>WiFi Test Item</p> <p>Packet RX (PHY OK) <input type="button" value="Start"/> <input type="button" value="Stop"/></p> <p>WiFi Setting</p> <p>Channel: 1</p> <p>Tx Rate: 11AX-MCS7</p> <p>RU: None</p> <p>Preamble: Long GI</p> <p>Bandwidth: 20MHz</p> <p>Freqtunning: 0</p> <p>Power Level: 14.0dBm</p> <p>Add Power: 0.0</p>	<p>BLE Test Item</p> <p>Test TX Infinite <input type="button" value="Start"/> <input type="button" value="Stop"/></p> <p>BLE Setting</p> <p>Channel: 19</p> <p>Phy: 2M</p> <p>Length: 37</p> <p>Payload: PRBS9</p> <p>Tx Power: 5</p>
---	---



3.9. BLE single carrier transmitting test

This test item is defined as the BLE single carrier Tx in BLE mode, which is used to test the frequency offset and other parameters. **BLE Test Item** needs to be set to **Test TX Tone**. **Channel** and **Tx Power** can be adjusted

As shown in [Figure 3-8. BLE LO TX TOOL setting](#), set **Channel** to 0 (2,402 MHz) and start test.

Figure 3-8. BLE LO TX TOOL setting

WiFi Test Item		BLE Test Item	
Packet TX	▼	Test TX Tone	▼
Start	Stop	Start	Stop
WiFi Setting		BLE Setting	
Channel	1 ▼	Channel	0 ▼
Tx Rate	OFDM6 ▼	Phy	1M ▼
RU	None ▼	Length	37 ▲▼
Preamble	Long GI ▼	Payload	PRBS9 ▼
Bandwidth	20MHz ▼	Tx Power	0 ▼
Freqtunning	-8 ▼		
Power Level	18.0dBm		
Add Power	0.0 ▼		

3.10. BLE Receiving test

This test item is used to test the received packet error rate (RX PER), receiving sensitivity, and other parameters in a **shielded room environment** without any interference.

1. Set "**WiFi Test Item**" as "**Packet RX**" and set "**Channel**" and "**Bandwidth**". Click "**Start**".
2. Set the device according to the parameters above and send package.
3. After the device ends, click "**Stop**". At this time, the "**RXOK**" field will display the correct number of packages received.

As shown in [Figure 3-9. Description of BLE receiving test commands](#), it indicates that for Channel=39(2480MHz), Phy="Coded". Test RX starts.

Figure 3-9. Description of BLE receiving test commands

WiFi Test Item	BLE Test Item
Packet RX (PHY OK)	Test RX
<input type="button" value="Start"/> <input type="button" value="Stop"/>	<input type="button" value="Start"/> <input type="button" value="Stop"/>
WiFi Setting	BLE Setting
Channel: 1	Channel: 39
Tx Rate: 11AX-MCS7	Phy: Coded
RU: None	Length: 37
Preamble: Long GI	Payload: PRBS9
Bandwidth: 20MHz	Tx Power: 5
Freqtunning: 0	
Power Level: 14.0dBm	
Add Power: 0.0	

3.11. Temperature display

Click **Thermal** to view the real-time return value of the built-in temperature sensor of the chip in the RF circuit [Figure 3-10. Temperature display](#). This value is not in the unit of Celsius, but it has a monotonically decreasing relationship with the actual temperature, that is, the larger the value is, the lower the temperature goes.

Figure 3-10. Temperature display

Counter	Message
<input type="button" value="Reset"/>	<input type="button" value="Clear"/> <input type="button" value="Save"/> <input checked="" type="checkbox"/> Serial Log
TxOK: <input type="text"/>	Read thermal: 603
TxErr: <input type="text"/>	
RxOK: <input type="text"/>	
RxErr: <input type="text"/>	
<input type="button" value="Thermal"/>	Console
<input type="text" value="603"/>	<input type="text"/>



4. RF Test - use serial port commands

This chapter introduces how to test transmitted and received RF parameters in non-signaling mode with the serial port commands.

4.1. Serial port connection

1. Open the UART tool on PC (the serial port tool "Husky Uart Tool" provided by GD is recommended), click the drop-down menu of "COM", select the corresponding COM port of DUT, and the default serial port configuration is as shown in [Figure 4-1. GD serial port tool](#):

Figure 4-1. GD serial port tool

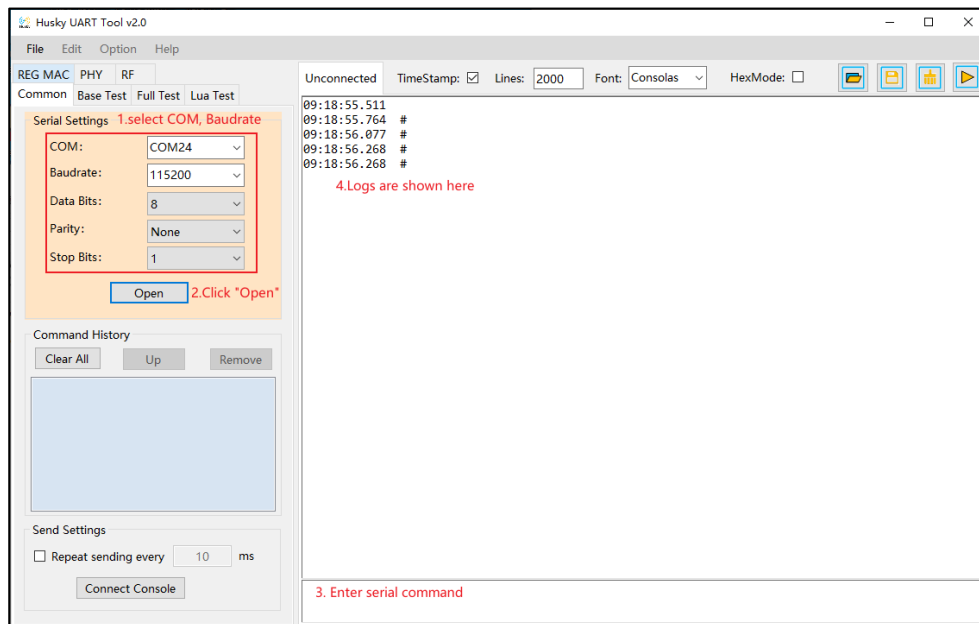

2. Click the button to connect the serial port. Press "Reset" at the side of the development board, and the serial port output box displays the log information, as shown in [Figure 4-2. Serial port boot information](#). At this time, left-click in the serial port input box and press "Enter" on the keyboard, and the log displays "#":

**Figure 4-2. Serial port boot information**

```
# ALW: MBL: First print.
ALW: MBL: Boot from Image 0.
ALW: MBL: Validate Image 0 OK.
ALW: MBL: Jump to Main Image (0x0800a000).
Build date: 2024/01/08 17:08:03
This firmware is for WiFi & BLE rf test.
=== RF initialization finished ===
=== WiFi calibration done ===
BLE local addr: 76:BA:ED:21:00:5C, type 0x0
=== BLE Adapter enable complete ===
```

4.2. Test Mode setting

- RF Test Mode should be set before test. Definition is in [Table 3-1. Test modes](#). Mode 2 is commonly used for test, enter the following command:

```
rf_mp_mode 2
```

4.3. WiFi discontinuous packet sending test

- To set the channel and bandwidth, enter the following commands:

```
wifi_set_ch <channel>
```

<Channel>:20M, 1-14 (only decimal system is supported).

- To set **Tx Rate** and **Add Power** and start **Tx**, enter the following commands:

```
wifi_tx_duty <percentage> <rate> [add_power]
```

<Percentage>:10. Set Tx percentage as 10%. It is a fixed value temporarily and can't be modified.

<Rate>: (only the hexadecimal system is supported) Refer to

[Table 4-1. Correspondence between rate and index](#)

[add_power]: -16.0 - 16.0, range = 32 db, step = 0.25 db

<> is mandatory field. [] is optional and will set as 0 if the field is not filled in. The same as below.

Table 4-1. Correspondence between rate and index

11B Rate	Index	11G Rate	Index	11N Rate	Index	11AX SU Rate	Index
1M	0x0	6M	0x4	MCS0	0x200	MCS0	0x500
2M	0x1	9M	0x5	MCS1	0x201	MCS1	0x501
5.5M	0x2	12M	0x6	MCS2	0x202	MCS2	0x502
11M	0x3	18M	0x7	MCS3	0x203	MCS3	0x503
		24M	0x8	MCS4	0x204	MCS4	0x504
		36M	0x9	MCS5	0x205	MCS5	0x505
		48M	0xa	MCS6	0x206	MCS6	0x506
		54M	0xb	MCS7	0x207	MCS7	0x507
						MCS8	0x508



Note: After this command is executed, the current default power level value and add power value will be displayed.

3. The instrument demodulates the signal and obtains the required data.
4. To stop Tx when the test is completed (or power adjustment is required, enter the following command, as shown in [Figure 4-3. Description of Packet Tx test commands](#).

wifi_tx_stop

Figure 4-3. Description of Packet Tx test commands

```
# wifi_set_ch 13
#
#
# wifi tx duty 10 0x509 0.25
rate:0x509, power level: 12.000000dBm, add_pwr: 0.250000dB
wifi_duty_tx: duty tx started
#
# wifi tx stop
wifi_stop_tx: mac bypass tx is to be stopped
#
#
#
```

1. set channel=13(2472MHz)

2. set tx duty=10%, rate=11AX MCS9
set addpower=0.25dB, so target power=
12+0.25=12.25dBm, start duty tx

3. RF Tester analyze signal

4. DUT stop duty tx

5. If it is required to adjust the power value, must stop Tx first and then restart Tx (modify the add power value). Do not directly modify it in the course of Tx.
6. To adjust the frequency offset, enter the following two commands (the commands can be used in the course of Tx.) First read the currently set value (decimal), and then adjust based on this value. If the measured frequency offset is positive, adjust the parameter value "tune" (hexadecimal) in the positive direction. Otherwise, adjust in the negative direction. Example is as shown in [Figure 4-4. Description of frequency offset correction commands](#).

rf_get_crystal_cap

rf_set_crystal_cap <tune>

<Tune>: '+' : 0x00 - 0x3f. As the capacitance increases, the frequency offset goes in the negative direction.

'-' : 0x7f - 0x40. As the capacitance decreases, the frequency offset goes in the positive direction.

Figure 4-4. Description of frequency offset correction commands

```

# rf_get_crystal_cap
rf_get_crystal_cap: 0
#
#
# rf_set_crystal_cap 0x5
#
# rf_set_crystal_cap 0x7c
#
#
#
    
```

1. get current "tune" value = 0
 2. set "tune" = 5, increase load capacitance
 3. set "tune" = -4, decrease load capacitance

4.4. WiFi continuous packet sending test

- To set the channel, enter the same command as that described in [WiFi discontinuous packet sending test](#).
- To set Tx Rate and Add Power and start Tx, enter the following commands:
wifi_tx_cont <rate> [add power]
 <Rate>: Refer to [Table 4-1. Correspondence between rate and index](#)
 [Add_power]: -16.0 - 16.0, range = 32 db, step = 0.25 db
- The instrument receives the signal and obtains the required data.
- To stop Tx when the test is completed or power adjustment is required, enter the command as that described in [WiFi discontinuous packet sending test](#). An example is as shown in [Figure 4-5. Description of Continuous Tx test commands](#).

Figure 4-5. Description of Continuous Tx test commands

```

# wifi_set_ch 11
#
#
# wifi_tx_cont 0x207 -1.75
rate:0x207, power level: 14.000000dBm, add_pwr: -1.750000dB
wifi_cont_tx: continuous tx started
#
#
# wifi_tx_stop
wifi_stop_tx: mac bypass tx is to be stopped
#
#
#
    
```

1. set channel=11(2462MHz)
 2. set rate=11N MCS7, addpower=-1.75dB so target power=12.25dBm, start continue tx
 3. RF Tester analyze signal
 4. stop continue tx

- The power modification method is the same as that described in [WiFi discontinuous packet sending test](#).

4.5. WiFi single carrier transmitting test

- To set the channel, enter the same command as that described in [WiFi discontinuous packet sending test](#).



2. Enter the following command to start Tx.
wifi_tx_lo
3. The instrument receives the signal and obtains the required data.
4. To stop Tx when the test is completed, enter the same command as that described in [WiFi discontinuous packet sending test](#). An example is as shown in [Figure 4-6. Description of LO Tx test commands](#).

Figure 4-6. Description of LO Tx test commands

```
# wifi_set_ch 3 → 1. set channel=3(2422MHz)
#
#
#
# wifi_tx_lo
wifi_tx_lo: tx lo started
# → 2. start lo tx
#
#
# wifi_tx_stop
wifi_stop_tx: mac bypass single tx is to be stopped
#
#
#
#
#
```

4.6. WiFi receiving test

1. To set the channel, enter the same CMD as that described in [WiFi discontinuous packet sending test](#).
2. Enter the following command to start the receiving test (namely to clear the receiving counter).
wifi_reset_trxc
3. Set channel and bandwidth through the serial port and start Rx. At this time, the instrument does not send packets. Determine whether the environment is clean through RxOK and RxErr counter. After the environment is confirmed to be clean, confirm the counter has been reset with following command before setting the instrument to send packets, like 11G6M, Power=-94dBm, packet length=1024Bytes, number of packet=1000.
wifi_phy_rxc
4. After the instrument has sent packets, enter the command in step 3 to obtain the number of packets received by the chip (number of RxOK and RxError packets. The reading is in hexadecimal system and needs to convert to decimal system.) and calculate the PER according to the following formula: $PER = (\text{number of packets sent by the instrument} - \text{number of RxOK packets}) / \text{number of packets sent by the instrument}$.
5. If retesting is required, repeat step 2 to step 4, as shown in [Figure 4-7. Description of Packet Rx test](#) commands. 0x3df=991, $PER = (1000 - 991) / 1000 = 0.9\%$, which indicates that the test passes.

Figure 4-7. Description of Packet Rx test commands

```

# wifi_set_ch 1
# wifi_reset_trxc
# wifi_phy_rxc
FCS OK: 0x00000000 ERR: 0x00000009, RX END: 0x00000009 ERR: 0x00000000,
#
# wifi_phy_rxc
FCS OK: 0x000003df ERR: 0x00000021, RX END: 0x00000400 ERR: 0x00000000,
#
#

```

1. set channel=1(2412MHz)
2. reset trx counter
3. confirm rx ok counter is reset
4. RF Tester send 1000 packets
5. read rx ok counter=3df=991

4.7. BLE discontinuous packet sending test

1. Set parameters according to the commands below and start the BLE discontinuous packet sending test

ble_test_tx <channel> <data length> <pkt payload> <phy> <tx power level>

Parameter definition is shown in [Table 4-2. CMD ble_test_tx parameter description](#).

Table 4-2. CMD ble_test_tx parameter description

Name	Value and Representation
channel	0x0-0x27=ch0-39
pkt length	0x0-0xFF=0B-255B
payload type	0x00/01/02/..=PRBS9/F0F0/AAAA/.
payload type	0x01/02/03/04 = 1M/2M/1Ms=8/1Ms=2
tx pow level	0x7E/7F=min/max, 0x05=5dBm/ 0xFF=-1dBm...

Specific example is as shown in [Figure 4-8. Description of commands for BLE discontinuous packet sending test](#).

Figure 4-8. Description of commands for BLE discontinuous packet sending test

```

# ble_test_tx 0xc 0x25 0x0 0x1 0x5
#
#
# ble_test_stop
#
#

```

1. set channel=12, pkt length=37B, payload type=PRBS9, phy type=LE1M, power=5dbm, start packet tx
2. RF Tester analyze signal
3. stop packet tx

2. The instrument starts to receive packets and demodulate.

3. Stop BLE Tx

ble_test_stop



4.8. BLE continuous packet sending test

1. Set parameters according to the commands below and start the BLE Discontinuous packet sending test

ble_test_tx_infinite <channel> <data length> <pkt payload> <phy> <tx power level>

Parameter definition is the same as that described in [BLE discontinuous packet sending test](#).

Specific example is as shown in [Figure 4-9. Description of commands for BLE continuous packet sending test](#).

Figure 4-9. Description of commands for BLE continuous packet sending test

```
# ble_test_tx_infinite 0x0 0x25 0x2 0x2 0x0
ble_test_tx_infinite status:0
#
#
#
# ble_test_stop
#
#
#
#
```

1. set channel=0, pkt length=37B, payload type=0xAA
phy type=LE2M, power=0dbm, start continue tx

2. RF Tester analyze signal
3. stop continue tx

2. The instrument starts to receive packets and demodulate.
3. Stop BLE Tx
ble_test_stop

4.9. BLE single carrier transmitting test

1. This test item is defined as the BLE single carrier Tx, which is used to test the frequency offset and other parameters.

As shown in [Figure 4-10. Description of commands for BLE LO Tx test](#), set **Channel** to 0 (2,402 MHz) and start **test**.

Figure 4-10. Description of commands for BLE LO Tx test

```
#
# ble_test_tx_tone 0x0 0x0 0x01 0x0
ble_test_tx_tone status:0
#
#
# ble_test_stop
#
```



4.10. BLE Receiving test

1. Set parameters according to the commands below and start the BLE Discontinuous packet sending test

ble_test_rx <channel> <phy> < modulation idx >

Usage: ble_test_rx <channel> <phy> <modulation idx>

Parameter definition is shown in [Table 4-3. CMD ble_test_rx parameter description](#).

Table 4-3. CMD ble_test_rx parameter description

Name	Value and Representation
channel	0x00-27 = ch0-39
phy	0x01/02/03 = 1M/2M/1Mcoded
modulation idx	0x00/01 = Standard/Stable

Specific example is as shown in [Figure 4-11. Description of BLE receiving test commands](#).

Figure 4-11. Description of BLE receiving test commands

```
# ble_test_rx 0xc 0x1 0x0
#
#
# ble_test_stop
# le test end, status 0x0, received pkt num:1316
#
#
#
```

1. set channel=12, rate=LE1M, start rx test

2. RF Tester send 1000 LE1M-PRBS9 packets
3. get received packet count=1316

4.11. Temperature display

1. Enter the following serial port command to display the return value of the built-in temperature sensor of the chip in the RF circuit in real time, usually 600 - 650 (as shown in [Figure 4-12. Description of temperature display commands](#)). This value is not in the unit of Celsius, but it has a monotonically decreasing relationship with the actual temperature, that is, the larger the value, the lower the temperature.

rf_get_thermal

Figure 4-12. Description of temperature display commands

```
# rf_get_thermal
temp_xtal: 609
#
```



5. Power consumption test

This chapter introduces how to test Tx and Rx power consumption in non-signaling mode with the RF test CMD and the DC power supply.

5.1. Test preparation

1. Test system: Based on [Figure 2-1. RF test system](#), one additional DC power supply is required to supply power to the module and record current data in real time, such as Keysight 66319D (This device is also used for the power consumption tests below).
2. Instrument configuration: It is mainly for the DC power supply, and the end of the power cable is welded with a Dupont wire for transfer. For stable output voltage, it is recommended to weld a large electrolytic capacitor (such as 100uF) at the end of the power supply cable. After the instrument is powered on, first set the output voltage of the instrument to 3.3V, and then set the output state to **OFF**.
3. Hardware preparation: Use the GD development board as an example here. Please refer to [Figure 2-2. Reference connection of GD development board](#). The DC-DC circuit on the mother board converts a 5V power input from the USB port into a 3.3V output, and the 3.3V output is connected to the 3.3V pad of the module with the jumper cap "J6". Disconnect this jumper cap, and connect the 3.3V and GND Dupont wire of the DC power output terminal to pin J6.2 and any GND pin (jack) respectively. As shown in [Figure 5-1. Power consumption test system](#), the 3.3V and the GND Dupont wire are connected to J6.2 and J9.4 respectively.
4. Software preparation: The firmware is the same as that used in the previous RF parameter test, named "**rf_test**".
5. Power-on sequence: First turn the output state of the DC power supply to **ON** to see a current change. Then connect the mother board and PC with a USB cable. After the **Device Manager** of PC identifies the serial port number, you can use serial port command line to perform the power consumption test.

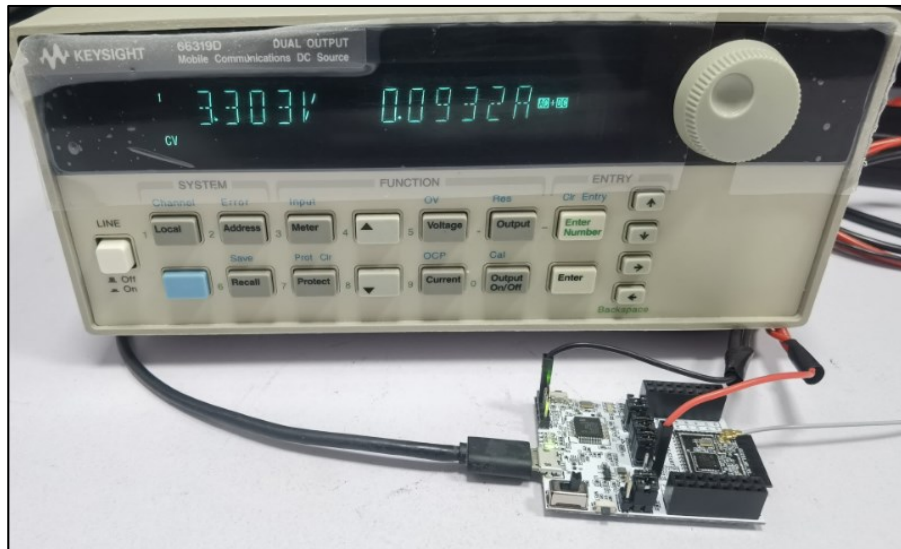
Figure 5-1. Power consumption test system

5.2. Transmitting power consumption test

To test the transmitting current, the transmitting mode with 100% Tx duty (continuous transmitting mode) is recommended, so that the current value displayed on the instrument is 100% power consumption of the transmitting circuit.

1. Following the last chapter, refer to [WiFi continuous packet sending test](#), set parameters with RF tools and start Tx.
2. The wireless test instrument receives the signal and measures the transmitting power after channel, bandwidth, and other parameters are set. To adjust power, stop Tx first, modify the add power value, and restart Tx.
3. Record the current value of the DC power supply.

As shown in [Figure 5-2. Tx power consumption test](#), (taking WiFi as an example, same for BLE), when **Channel** is set to 1 (2,422 MHz), **Tx Rate** to 11G 54M, and **Power Level** to 15 dBm in **Continuous Tx** mode, the average total current of the chip is 270.1 mA at 3.3V.

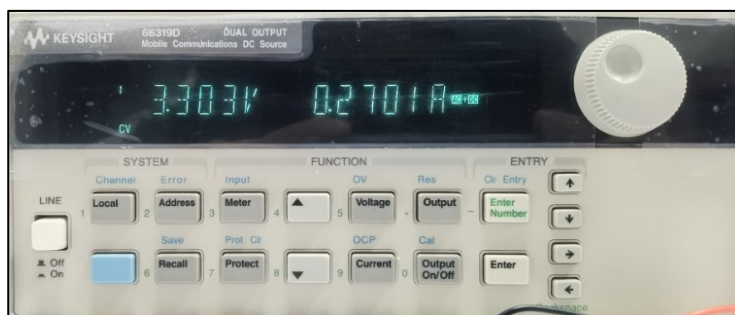
Figure 5-2. Tx power consumption test



5.3. Receiving power consumption test

1. It is recommended to perform the receiving power consumption test in the shielded room to prevent environmental changes from interfering with the test results.
2. Generate and load a wave file with the instrument (or use the instrument's own wave). For the Rx power consumption test, the duty of packets received by the chip should also be close to 100%. When the wave file is generated, you can modify the "wave gap" option to "SIFS" (11 B = 10 us, 11 G/N/AX = 16 us) to achieve the maximum receiving duty.
3. Confirm whether the environment is "clean" with reference to [WiFi receiving test](#). At this moment, if the current value of the DC power supply is recorded, it represents the power consumption in **RX Listen** mode.
4. Set the number of packets sent by the instrument to **Continuous TX**, and the number in **RxOK** in the test tool is increasing. The recorded current value of the DC power supply represents the power consumption in the packet receiving mode.

As shown in [Figure 5-3. Rx power consumption test](#), (taking WiFi as an example, same for BLE), when **Channel** is set to 1 (2,422 MHz), **Tx Rate** to 11B 11M, and **Power Level** to -70 dBm in **Continuous Packet Rx** mode, the average total current of the chip is 93.5 mA at 3.3V.

Figure 5-3. Rx power consumption test

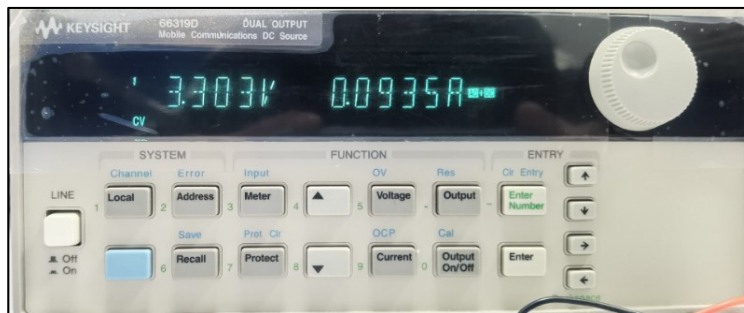



6. FAQ

1. Q: When the test is performed by entering the serial port command, no log is returned after the command is entered on the serial port tool.
A: Confirm the hardware configuration of DUT, and check whether the PIN (UART, NRST, PU, BOOT, 3V3, GND) are connected correctly.
2. Q: When the chip is initialized in the test tool, failure is displayed.
A: Confirm whether the version of the firmware burned in DUT is the RF test firmware named "**rf_test**". Use Husky Tool to confirm whether the serial port communication is normal, and whether the commands such as input mode setting are valid.
3. Q: During the test, the instrument cannot capture the Tx signal of DUT (or the captured DUT Tx power is very small).
A: Confirm whether the instrument settings are correct, including the mode, port, channel, reference power, and line loss compensation.
Confirm whether the DUT hardware connections are correct, including DUT RF path and RF cable.
Confirm whether the DUT settings are correct, including the settings of channel, bandwidth, and power adjustment.
4. Q: The test results of receiving sensitivity are poor.
A: The solution is the same as that for Q3.
Check whether the environment is "clean" with reference to [WiFi receiving test](#).



7. Revision history

[Table 7-1. Revision history](#) is the history of the version of the document.

Table 7-1. Revision history

Revision No.	Description	Date
1.0	Initial Release	Nov.17 th ,2023
1.1	Add description of BLE LO TX TEST	Mar.1 st ,2024
1.2	Modify chapter 2	Jul.18 th ,2024



Important Notice

This document is the property of GigaDevice Semiconductor Inc. and its subsidiaries (the "Company"). This document, including any product of the Company described in this document (the "Product"), is owned by the Company under the intellectual property laws and treaties of the People's Republic of China and other jurisdictions worldwide. The Company reserves all rights under such laws and treaties and does not grant any license under its patents, copyrights, trademarks, or other intellectual property rights. The names and brands of third party referred thereto (if any) are the property of their respective owner and referred to for identification purposes only.

The Company makes no warranty of any kind, express or implied, with regard to this document or any Product, including, but not limited to, the implied warranties of merchantability and fitness for a particular purpose. The Company does not assume any liability arising out of the application or use of any Product described in this document. Any information provided in this document is provided only for reference purposes. It is the responsibility of the user of this document to properly design, program, and test the functionality and safety of any application made of this information and any resulting product. Except for customized products which have been expressly identified in the applicable agreement, the Products are designed, developed, and/or manufactured for ordinary business, industrial, personal, and/or household applications only. The Products are not designed, intended, or authorized for use as components in systems designed or intended for the operation of weapons, weapons systems, nuclear installations, atomic energy control instruments, combustion control instruments, airplane or spaceship instruments, transportation instruments, traffic signal instruments, life-support devices or systems, other medical devices or systems (including resuscitation equipment and surgical implants), pollution control or hazardous substances management, or other uses where the failure of the device or Product could cause personal injury, death, property or environmental damage ("Unintended Uses"). Customers shall take any and all actions to ensure using and selling the Products in accordance with the applicable laws and regulations. The Company is not liable, in whole or in part, and customers shall and hereby do release the Company as well as its suppliers and/or distributors from any claim, damage, or other liability arising from or related to all Unintended Uses of the Products. Customers shall indemnify and hold the Company as well as its suppliers and/or distributors harmless from and against all claims, costs, damages, and other liabilities, including claims for personal injury or death, arising from or related to any Unintended Uses of the Products.

Information in this document is provided solely in connection with the Products. The Company reserves the right to make changes, corrections, modifications or improvements to this document and Products and services described herein at any time, without notice.