

GigaDevice Semiconductor Inc.

GD32A103xx

Arm[®] Cortex[®]-M4 32-bit MCU

Datasheet

Revision 1.0

(Jun. 2024)

Table of Contents

| | |
|---|-----------|
| Table of Contents | 1 |
| List of Figures | 4 |
| List of Tables | 5 |
| 1. General description | 7 |
| 2. Device overview | 8 |
| 2.1. Device information | 8 |
| 2.2. Block diagram..... | 9 |
| 2.3. Pinouts and pin assignment | 10 |
| 2.4. Memory map | 12 |
| 2.5. Clock tree | 16 |
| 2.6. Pin definitions..... | 16 |
| 2.6.1. GD32A103Vx LQFP100 pin definitions | 17 |
| 2.6.2. GD32A103Rx LQFP64 pin definitions | 23 |
| 2.6.3. GD32A103Cx LQFP48 pin definitions | 27 |
| 2.6.4. GD32A103Tx QFN36 pin definitions | 30 |
| 3. Functional description | 34 |
| 3.1. Arm® Cortex®-M4 core | 34 |
| 3.2. On-chip memory | 34 |
| 3.3. Clock, reset and supply management..... | 35 |
| 3.4. Boot modes..... | 35 |
| 3.5. Power saving modes | 36 |
| 3.6. Analog to digital converter (ADC) | 36 |
| 3.7. Digital to analog converter (DAC)..... | 37 |
| 3.8. DMA | 37 |
| 3.9. General-purpose inputs/outputs (GPIOs) | 37 |
| 3.10. Timers and PWM generation | 38 |
| 3.11. Real time clock (RTC) | 39 |
| 3.12. Inter-integrated circuit (I2C) | 39 |
| 3.13. Serial peripheral interface (SPI) | 39 |
| 3.14. Universal synchronous asynchronous receiver transmitter (USART) | 40 |

| | | |
|-----------|--|-----------|
| 3.15. | Inter-IC sound (I2S) | 40 |
| 3.16. | Universal serial bus full-speed interface (USBFS)..... | 40 |
| 3.17. | Controller area network (CAN) | 41 |
| 3.18. | External memory controller (EXMC) | 41 |
| 3.19. | Debug mode | 41 |
| 3.20. | Package and operation temperature..... | 41 |
| 4. | Electrical characteristics..... | 43 |
| 4.1. | Absolute maximum ratings..... | 43 |
| 4.2. | Operating conditions characteristics..... | 43 |
| 4.3. | Power consumption | 45 |
| 4.4. | EMC characteristics | 52 |
| 4.5. | Power supply supervisor characteristics | 53 |
| 4.6. | External clock characteristics | 54 |
| 4.7. | Internal clock characteristics | 57 |
| 4.8. | PLL characteristics..... | 58 |
| 4.9. | Memory characteristics..... | 59 |
| 4.10. | NRST pin characteristics | 59 |
| 4.11. | GPIO characteristics | 60 |
| 4.12. | ADC characteristics | 62 |
| 4.13. | Temperature sensor characteristics..... | 63 |
| 4.14. | DAC characteristics | 64 |
| 4.15. | I2C characteristics | 65 |
| 4.16. | SPI characteristics | 66 |
| 4.17. | I2S characteristics..... | 67 |
| 4.18. | USART characteristics..... | 69 |
| 4.19. | CAN characteristics | 69 |
| 4.20. | USBFS characteristics..... | 69 |
| 4.21. | EXMC characteristics..... | 70 |
| 4.22. | TIMER characteristics..... | 74 |
| 4.23. | WDGT characteristics | 74 |
| 4.24. | Parameter conditions..... | 75 |
| 5. | Package information..... | 76 |



| | | |
|------|---|----|
| 5.1. | LQFP100 package outline dimensions..... | 76 |
| 5.2. | LQFP64 package outline dimensions..... | 78 |
| 5.3. | LQFP48 package outline dimensions..... | 80 |
| 5.4. | QFN36 package outline dimensions | 82 |
| 5.5. | Thermal characteristics | 84 |
| 6. | Ordering information | 86 |
| 7. | Revision history | 87 |

List of Figures

| | |
|--|----|
| Figure 2-1. GD32A103xx block diagram | 9 |
| Figure 2-2. GD32A103Vx LQFP100 pinouts | 10 |
| Figure 2-3. GD32A103Rx LQFP64 pinouts | 11 |
| Figure 2-4. GD32A103Cx LQFP48 pinouts | 11 |
| Figure 2-5. GD32A103Tx QFN36 pinouts | 12 |
| Figure 2-6. GD32A103xx clock tree..... | 16 |
| Figure 4-1. Recommended power supply decoupling capacitors ⁽¹⁾⁽²⁾ | 44 |
| Figure 4-2. Typical supply current consumption in Run mode | 50 |
| Figure 4-3. Typical supply current consumption in Sleep mode..... | 50 |
| Figure 4-4. Recommended external NRST pin circuit..... | 60 |
| Figure 4-5. I/O port AC characteristics definition..... | 61 |
| Figure 4-6. I2C bus timing diagram..... | 66 |
| Figure 4-7. SPI timing diagram - master mode | 67 |
| Figure 4-8. SPI timing diagram - slave mode..... | 67 |
| Figure 4-9. I2S timing diagram - master mode | 68 |
| Figure 4-10. I2S timing diagram - slave mode | 69 |
| Figure 4-11. USBFS timings: definition of data signal rise and fall time | 70 |
| Figure 5-1. LQFP100 package outline | 76 |
| Figure 5-2. LQFP100 recommended footprint | 77 |
| Figure 5-3. LQFP64 package outline | 78 |
| Figure 5-4. LQFP64 recommended footprint | 79 |
| Figure 5-5. LQFP48 package outline | 80 |
| Figure 5-6. LQFP48 recommended footprint | 81 |
| Figure 5-7. QFN36 package outline | 82 |
| Figure 5-8. QFN36 recommended footprint | 83 |

List of Tables

| | |
|--|----|
| Table 2-1. GD32A103xx devices features and peripheral list | 8 |
| Table 2-2. GD32A103xx memory map | 12 |
| Table 2-3. GD32A103Vx LQFP100 pin definitions | 17 |
| Table 2-4. GD32A103Rx LQFP64 pin definitions | 23 |
| Table 2-5. GD32A103Cx LQFP48 pin definitions | 27 |
| Table 2-6. GD32A103Tx QFN36 pin definitions | 30 |
| Table 4-1. Absolute maximum ratings ⁽¹⁾⁽⁴⁾ | 43 |
| Table 4-2. DC operating conditions | 43 |
| Table 4-3. Clock frequency ⁽¹⁾ | 44 |
| Table 4-4. Operating conditions at Power up/ Power down ⁽¹⁾ | 44 |
| Table 4-5. Start-up timings of Operating conditions ⁽¹⁾⁽²⁾⁽³⁾ | 44 |
| Table 4-6. Power saving mode wakeup timings characteristics ⁽¹⁾⁽²⁾ | 45 |
| Table 4-7. Power consumption characteristics ⁽²⁾⁽³⁾⁽⁴⁾⁽⁵⁾⁽⁶⁾ | 45 |
| Table 4-8. Peripheral current consumption characteristics ⁽¹⁾ | 51 |
| Table 4-13. System level ESD and EFT characteristics ⁽¹⁾ | 52 |
| Table 4-14. EMI characteristics ⁽¹⁾ | 52 |
| Table 4-15. Component level ESD and latch-up characteristics ⁽¹⁾ | 53 |
| Table 4-10. Power supply supervisor characteristics | 53 |
| Table 4-12. High speed external clock (HXTAL) generated from a crystal/ceramic characteristics | 54 |
| Table 4-13. High speed external clock characteristics (HXTAL in bypass mode) | 55 |
| Table 4-14. Low speed external clock (LXTAL) generated from a crystal/ceramic characteristics | 56 |
| Table 4-15. Low speed external user clock characteristics (LXTAL in bypass mode) | 56 |
| Table 4-16. High speed internal clock (IRC8M) characteristics | 57 |
| Table 4-17. Low speed internal clock (IRC40K) characteristics | 57 |
| Table 4-18. High speed internal clock (IRC48M) characteristics | 58 |
| Table 4-19. PLL characteristics | 58 |
| Table 4-20. PLL1/2 characteristics | 58 |
| Table 4-21. Flash memory characteristics | 59 |
| Table 4-22. NRST pin characteristics | 59 |
| Table 4-23. I/O port DC characteristics ⁽¹⁾⁽³⁾ | 60 |
| Table 4-24. I/O port AC characteristics ⁽¹⁾⁽²⁾ | 61 |
| Table 4-25. ADC characteristics | 62 |
| Table 4-26. ADC R_{AIN} max for $f_{ADC} = 42$ MHz | 62 |
| Table 4-27. ADC dynamic accuracy at $f_{ADC} = 14$ MHz ⁽¹⁾ | 63 |
| Table 4-28. ADC dynamic accuracy at $f_{ADC} = 42$ MHz ⁽¹⁾ | 63 |
| Table 4-29. ADC static accuracy at $f_{ADC} = 42$ MHz ⁽¹⁾ | 63 |
| Table 4-30. Temperature sensor characteristics ⁽¹⁾ | 63 |
| Table 4-31. DAC characteristics | 64 |
| Table 4-32. I2C characteristics ⁽¹⁾⁽²⁾ | 65 |
| Table 4-33. Standard SPI characteristics ⁽¹⁾ | 66 |



| | |
|--|----|
| Table 4-34. I2S characteristics ⁽¹⁾⁽²⁾ | 67 |
| Table 4-35. USART characteristics ⁽¹⁾ | 69 |
| Table 4-36. USBFS start up time | 69 |
| Table 4-37. USBFS DC electrical characteristics | 70 |
| Table 4-38. USBFS electrical characteristics ⁽¹⁾ | 70 |
| Table 4-39. Asynchronous non-multiplexed SRAM/PSRAM/NOR read timings ⁽¹⁾⁽²⁾⁽³⁾ | 70 |
| Table 4-40. Asynchronous non-multiplexed SRAM/PSRAM/NOR write timings ⁽¹⁾⁽²⁾⁽³⁾ | 71 |
| Table 4-41. Asynchronous multiplexed PSRAM/NOR read timings ⁽¹⁾⁽²⁾⁽³⁾ | 71 |
| Table 4-42. Asynchronous multiplexed PSRAM/NOR write timings ⁽¹⁾⁽²⁾⁽³⁾ | 72 |
| Table 4-43. Synchronous multiplexed PSRAM/NOR read timings ⁽¹⁾⁽²⁾⁽³⁾ | 72 |
| Table 4-44. Synchronous multiplexed PSRAM write timings ⁽¹⁾⁽²⁾⁽³⁾ | 72 |
| Table 4-45. Synchronous non-multiplexed PSRAM/NOR read timings ⁽¹⁾⁽²⁾⁽³⁾ | 73 |
| Table 4-46. Synchronous non-multiplexed PSRAM write timings ⁽¹⁾⁽²⁾⁽³⁾ | 73 |
| Table 4-47. TIMER characteristics ⁽¹⁾ | 74 |
| Table 4-48. FWDGT min/max timeout period at 40 kHz (IRC40K) ⁽¹⁾ | 74 |
| Table 4-49. WWDGT min-max timeout value at 60 MHz (f_{PCLK1}) ⁽¹⁾ | 74 |
| Table 5-1. LQFP100 package dimensions | 76 |
| Table 5-2. LQFP64 package dimensions | 78 |
| Table 5-3. LQFP48 package dimensions | 80 |
| Table 5-4. QFN36 package dimensions | 82 |
| Table 5-5. Package thermal characteristics ⁽¹⁾ | 84 |
| Table 6-1. Part ordering code for GD32A103xx devices | 86 |
| Table 7-1. Revision history | 87 |

1. General description

The GD32A103xx device belongs to the connectivity line of GD32 MCU Family. It is a 32-bit general-purpose microcontroller based on the Arm® Cortex® M4 RISC core with best cost-performance ratio in terms of enhanced processing capacity, reduced power consumption and peripheral set. The Cortex®-M4 core features implements a full set of DSP instructions to address digital signal control markets that demand an efficient, easy-to-use blend of control and signal processing capabilities. It also provides powerful trace technology for enhanced application security and advanced debug support.

The GD32A103xx device incorporates the Arm® Cortex®-M4 32-bit processor core operating at 120 MHz frequency with Flash accesses to obtain maximum efficiency. It provides up to 128 KB eFlash memory and 32 KB SRAM memory. An extensive range of enhanced I/Os and peripherals connected to two APB buses. The devices offer up to two 12-bit 3 MSPS ADCs, two 12-bit DACs, up to ten general 16-bit timers, two 16-bit PWM advanced timers, and two 16-bit basic timers, as well as standard and advanced communication interfaces: up to three SPIs, two I2Cs, three USARTs and two UARTs, two I2Ss, an USBFS and CAN-FD.

The device operates from 1.71 to 3.6 V power supply and available in –40 to +105 °C temperature range. Several power saving modes provide the flexibility for maximum optimization between wakeup latency and power consumption, an especially important consideration in low power applications.

The above features make GD32A103xx devices suitable for a wide range of interconnection and advanced applications, especially in areas such as BCM, HVAC, BMS, OBC(on-board charger), automotive radar, automotive vision, DC-DC, automobile instrument, IVI(in-vehicle infotainment) car lighting system, smart cockpit system, ADAS, motor and power and so on.



2. Device overview

2.1. Device information

Table 2-1. GD32A103xx devices features and peripheral list

| Part Number | | GD32A103xx | | | |
|--------------|------------------------|----------------------------|-----------------------------------|-----------------------------------|-----------------------------------|
| | | TB | CB | RB | VB |
| Flash (KB) | | 128 | 128 | 128 | 128 |
| SRAM (KB) | | 32 | 32 | 32 | 32 |
| Timers | General timer(16-bit) | 4 <small>(1-4)</small> | 10 <small>(1-4,8-13)</small> | 10 <small>(1-4,8-13)</small> | 10 <small>(1-4,8-13)</small> |
| | Advanced timer(16-bit) | 1 <small>(0)</small> | 1 <small>(0)</small> | 2 <small>(0,7)</small> | 2 <small>(0,7)</small> |
| | SysTick | 1 | 1 | 1 | 1 |
| | Basic timer(16-bit) | 2 <small>(5,6)</small> | 2 <small>(5,6)</small> | 2 <small>(5,6)</small> | 2 <small>(5,6)</small> |
| | Watchdog | 2 | 2 | 2 | 2 |
| | RTC | 1 | 1 | 1 | 1 |
| Connectivity | USART | 2 <small>(0-1)</small> | 3 <small>(0-2)</small> | 3 <small>(0-2)</small> | 3 <small>(0-2)</small> |
| | UART | 0 | 0 | 2 <small>(3-4)</small> | 2 <small>(3-4)</small> |
| | I2C | 1 <small>(0)</small> | 2 <small>(0-1)</small> | 2 <small>(0-1)</small> | 2 <small>(0-1)</small> |
| | SPI/I2S | 1/0 <small>(0-)</small> | 3/2 <small>(0-2)/(1-2)</small> | 3/2 <small>(0-2)/(1-2)</small> | 3/2 <small>(0-2)/(1-2)</small> |
| | CAN | 2xFD | 2xFD | 2xFD | 2xFD |
| | USBFS | 1 | 1 | 1 | 1 |
| GPIO | | 26 | 37 | 51 | 80 |
| EXMC | | 0 | 0 | 0 | 1 |
| EXTI | | 16 | 16 | 16 | 16 |
| ADC | Units | 2 | 2 | 2 | 2 |
| | Channels | 10 | 10 | 16 | 16 |
| DAC | | 2 | 2 | 2 | 2 |
| Package | | QFN36 | LQFP48 | LQFP64 | LQFP100 |

2.2. Block diagram

Figure 2-1.GD32A103xx block diagram

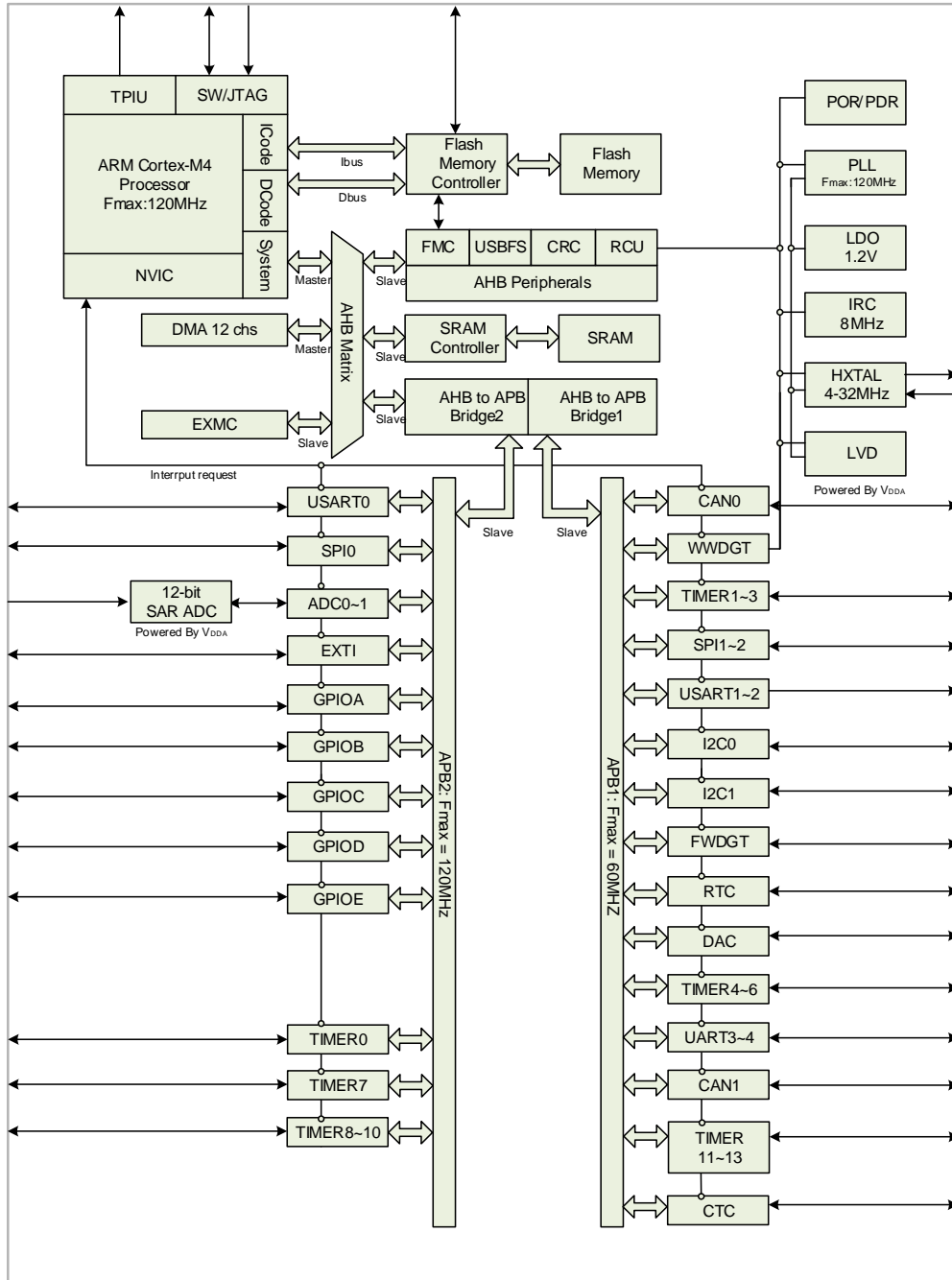

2.3. Pinouts and pin assignment

Figure 2-2. GD32A103Vx LQFP100 pinouts

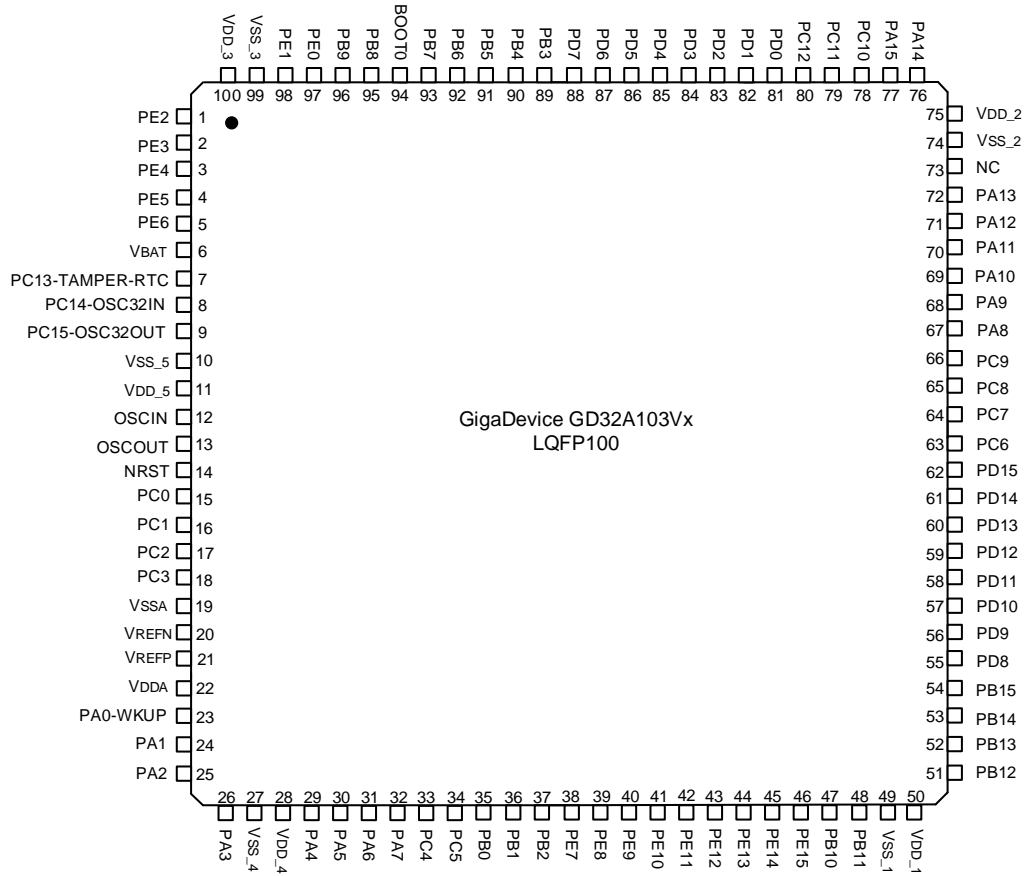

Figure 2-3. GD32A103Rx LQFP64 pinouts

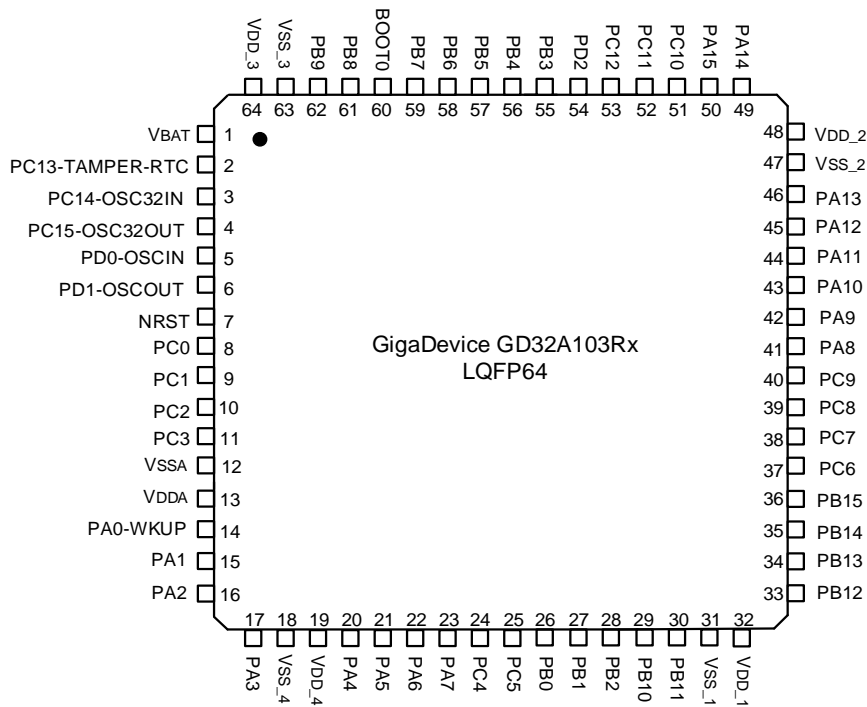

Figure 2-4. GD32A103Cx LQFP48 pinouts

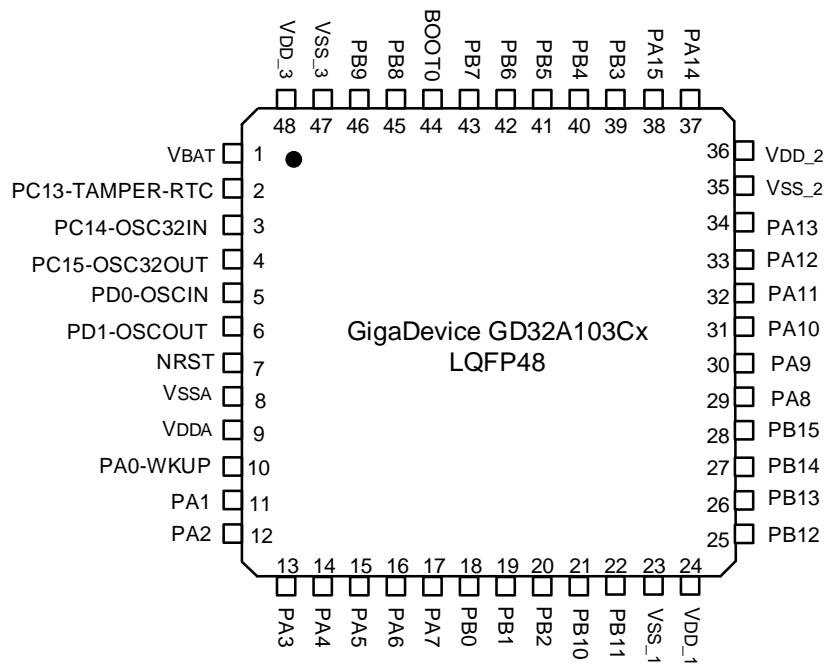
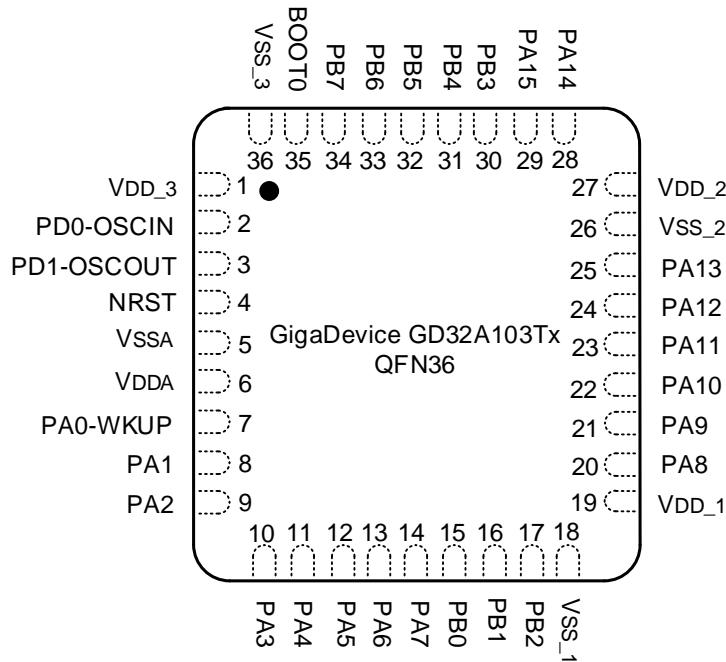

Figure 2-5. GD32A103Tx QFN36 pinouts



2.4. Memory map

Table 2-2. GD32A103xx memory map

| Pre-defined regions | Bus | Address | Peripherals |
|---------------------|------|---------------------------|-----------------------|
| External device | AHB3 | 0xA000 0000 - 0xA000 0FFF | EXMC - SWREG |
| External RAM | | 0x9000 0000 - 0x9FFF FFFF | Reserved |
| | | 0x7000 0000 - 0x8FFF FFFF | Reserved |
| | | 0x6000 0000 - 0x63FF FFFF | EXMC - NOR/PSRAM/SRAM |
| Peripheral | AHB1 | 0x5000 0000 - 0x5003 FFFF | USBFS |
| | | 0x4008 0000 - 0x4FFF FFFF | Reserved |
| | | 0x4004 0000 - 0x4007 FFFF | Reserved |
| | | 0x4002 BC00 - 0x4003 FFFF | Reserved |
| | | 0x4002 B000 - 0x4002 BBFF | Reserved |
| | | 0x4002 A000 - 0x4002 AFFF | Reserved |
| | | 0x4002 8000 - 0x4002 9FFF | Reserved |
| | | 0x4002 6800 - 0x4002 7FFF | Reserved |
| | | 0x4002 6400 - 0x4002 67FF | Reserved |
| | | 0x4002 6000 - 0x4002 63FF | Reserved |
| | | 0x4002 5000 - 0x4002 5FFF | Reserved |
| | | 0x4002 4000 - 0x4002 4FFF | Reserved |
| | | 0x4002 3C00 - 0x4002 3FFF | Reserved |

| Pre-defined regions | Bus | Address | Peripherals |
|---------------------------|---------------------------|---------------------------|---------------------------|
| | | 0x4002 3800 - 0x4002 3BFF | Reserved |
| | | 0x4002 3400 - 0x4002 37FF | Reserved |
| | | 0x4002 3000 - 0x4002 33FF | CRC |
| | | 0x4002 2C00 - 0x4002 2FFF | Reserved |
| | | 0x4002 2800 - 0x4002 2BFF | Reserved |
| | | 0x4002 2400 - 0x4002 27FF | Reserved |
| | | 0x4002 2000 - 0x4002 23FF | FMC |
| | | 0x4002 1C00 - 0x4002 1FFF | Reserved |
| | | 0x4002 1800 - 0x4002 1BFF | Reserved |
| | | 0x4002 1400 - 0x4002 17FF | Reserved |
| | | 0x4002 1000 - 0x4002 13FF | RCU |
| | | 0x4002 0C00 - 0x4002 0FFF | Reserved |
| | | 0x4002 0800 - 0x4002 0BFF | Reserved |
| | | 0x4002 0400 - 0x4002 07FF | DMA1 |
| | | 0x4002 0000 - 0x4002 03FF | DMA0 |
| | | 0x4001 8400 - 0x4001 FFFF | Reserved |
| | | 0x4001 8000 - 0x4001 83FF | Reserved |
| | | APB2 | 0x4001 7C00 - 0x4001 7FFF |
| | 0x4001 7800 - 0x4001 7BFF | | Reserved |
| | 0x4001 7400 - 0x4001 77FF | | Reserved |
| | 0x4001 7000 - 0x4001 73FF | | Reserved |
| | 0x4001 6C00 - 0x4001 6FFF | | Reserved |
| | 0x4001 6800 - 0x4001 6BFF | | Reserved |
| | 0x4001 5C00 - 0x4001 67FF | | Reserved |
| | 0x4001 5800 - 0x4001 5BFF | | Reserved |
| | 0x4001 5400 - 0x4001 57FF | | TIMER10 |
| | 0x4001 5000 - 0x4001 53FF | | TIMER9 |
| | 0x4001 4C00 - 0x4001 4FFF | | TIMER8 |
| | 0x4001 4800 - 0x4001 4BFF | | Reserved |
| | 0x4001 4400 - 0x4001 47FF | | Reserved |
| | 0x4001 4000 - 0x4001 43FF | | Reserved |
| | 0x4001 3C00 - 0x4001 3FFF | | Reserved |
| | 0x4001 3800 - 0x4001 3BFF | | USART0 |
| | 0x4001 3400 - 0x4001 37FF | | TIMER7 |
| | 0x4001 3000 - 0x4001 33FF | | SPI0 |
| | 0x4001 2C00 - 0x4001 2FFF | TIMER0 | |
| 0x4001 2800 - 0x4001 2BFF | ADC1 | | |
| 0x4001 2400 - 0x4001 27FF | ADC0 | | |
| 0x4001 2000 - 0x4001 23FF | Reserved | | |

| Pre-defined regions | Bus | Address | Peripherals | |
|---------------------------|----------|---------------------------|---------------------------|-------------------|
| | | 0x4001 1C00 - 0x4001 1FFF | Reserved | |
| | | 0x4001 1800 - 0x4001 1BFF | GPIOE | |
| | | 0x4001 1400 - 0x4001 17FF | GPIOD | |
| | | 0x4001 1000 - 0x4001 13FF | GPIOC | |
| | | 0x4001 0C00 - 0x4001 0FFF | GPIOB | |
| | | 0x4001 0800 - 0x4001 0BFF | GPIOA | |
| | | 0x4001 0400 - 0x4001 07FF | EXTI | |
| | | 0x4001 0000 - 0x4001 03FF | AFIO | |
| | APB1 | | 0x4000 CC00 - 0x4000 FFFF | Reserved |
| | | | 0x4000 C800 - 0x4000 CBFF | CTC |
| | | | 0x4000 C400 - 0x4000 C7FF | Reserved |
| | | | 0x4000 C000 - 0x4000 C3FF | Reserved |
| | | | 0x4000 8000 - 0x4000 BFFF | Reserved |
| | | | 0x4000 7C00 - 0x4000 7FFF | Reserved |
| | | | 0x4000 7800 - 0x4000 7BFF | Reserved |
| | | | 0x4000 7400 - 0x4000 77FF | DAC |
| | | | 0x4000 7000 - 0x4000 73FF | PMU |
| | | | 0x4000 6C00 - 0x4000 6FFF | BKP |
| | | | 0x4000 6800 - 0x4000 6BFF | CAN1 |
| | | | 0x4000 6400 - 0x4000 67FF | CAN0 |
| | | | 0x4000 6000 - 0x4000 63FF | CAN SRAM 1K bytes |
| | | | 0x4000 5C00 - 0x4000 5FFF | Reserved |
| | | | 0x4000 5800 - 0x4000 5BFF | I2C1 |
| | | | 0x4000 5400 - 0x4000 57FF | I2C0 |
| | | | 0x4000 5000 - 0x4000 53FF | UART4 |
| | | | 0x4000 4C00 - 0x4000 4FFF | UART3 |
| | | | 0x4000 4800 - 0x4000 4BFF | USART2 |
| | | | 0x4000 4400 - 0x4000 47FF | USART1 |
| | | | 0x4000 4000 - 0x4000 43FF | Reserved |
| | | | 0x4000 3C00 - 0x4000 3FFF | SPI2/I2S2 |
| | | | 0x4000 3800 - 0x4000 3BFF | SPI1/I2S1 |
| | | | 0x4000 3400 - 0x4000 37FF | Reserved |
| | | | 0x4000 3000 - 0x4000 33FF | FWDGT |
| | | | 0x4000 2C00 - 0x4000 2FFF | WWDGT |
| 0x4000 2800 - 0x4000 2BFF | RTC | | | |
| 0x4000 2400 - 0x4000 27FF | Reserved | | | |
| 0x4000 2000 - 0x4000 23FF | TIMER13 | | | |
| 0x4000 1C00 - 0x4000 1FFF | TIMER12 | | | |
| 0x4000 1800 - 0x4000 1BFF | TIMER11 | | | |

| Pre-defined regions | Bus | Address | Peripherals |
|---------------------|-----|---------------------------|--------------------------------------|
| | | 0x4000 1400 - 0x4000 17FF | TIMER6 |
| | | 0x4000 1000 - 0x4000 13FF | TIMER5 |
| | | 0x4000 0C00 - 0x4000 0FFF | TIMER4 |
| | | 0x4000 0800 - 0x4000 0BFF | TIMER3 |
| | | 0x4000 0400 - 0x4000 07FF | TIMER2 |
| | | 0x4000 0000 - 0x4000 03FF | TIMER1 |
| SRAM | AHB | 0x2007 0000 - 0x3FFF FFFF | Reserved |
| | | 0x2006 0000 - 0x2006 FFFF | Reserved |
| | | 0x2003 0000 - 0x2005 FFFF | Reserved |
| | | 0x2002 0000 - 0x2002 FFFF | Reserved |
| | | 0x2001 C000 - 0x2001 FFFF | SRAM |
| | | 0x2001 8000 - 0x2001 BFFF | |
| | | 0x2000 5000 - 0x2001 7FFF | |
| | | 0x2000 0000 - 0x2000 4FFF | |
| Code | AHB | 0x1FFF F810 - 0x1FFF FFFF | Reserved |
| | | 0x1FFF F800 - 0x1FFF F80F | Option Bytes |
| | | 0x1FFF F000 - 0x1FFF F7FF | Boot loader |
| | | 0x1FFF C010 - 0x1FFF EFFF | |
| | | 0x1FFF C000 - 0x1FFF C00F | |
| | | 0x1FFF B000 - 0x1FFF BFFF | |
| | | 0x1FFF 7A10 - 0x1FFF AFFF | Reserved |
| | | 0x1FFF 7800 - 0x1FFF 7A0F | Reserved |
| | | 0x1FFF 0000 - 0x1FFF 77FF | Reserved |
| | | 0x1FFE C010 - 0x1FFE FFFF | Reserved |
| | | 0x1FFE C000 - 0x1FFE C00F | Reserved |
| | | 0x1001 0000 - 0x1FFE BFFF | Reserved |
| | | 0x1000 0000 - 0x1000 FFFF | Reserved |
| | | 0x083C 0000 - 0x0FFF FFFF | Reserved |
| | | 0x0830 0000 - 0x083B FFFF | Reserved |
| | | 0x0810 0000 - 0x082F FFFF | Main Flash |
| | | 0x0802 0000 - 0x080F FFFF | |
| | | 0x0800 0000 - 0x0801 FFFF | |
| | | 0x0030 0000 - 0x07FF FFFF | Reserved |
| | | 0x0010 0000 - 0x002F FFFF | Aliased to Main Flash or Boot loader |
| | | 0x0002 0000 - 0x000F FFFF | |
| | | 0x0000 0000 - 0x0001 FFFF | |

2.5. Clock tree

Figure 2-6. GD32A103xx clock tree

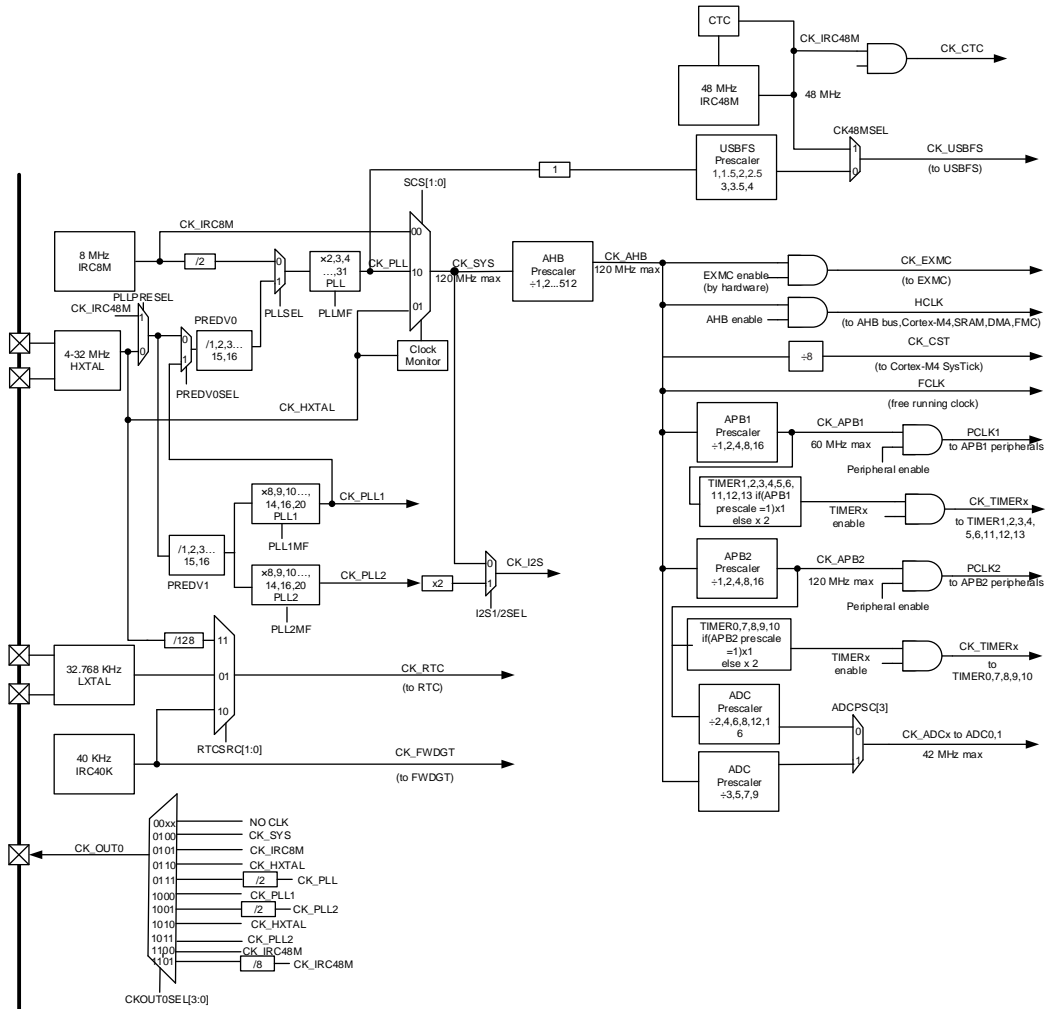

Legend:

HXTAL: 4 to 32 MHz High Speed crystal oscillator

LXTAL: 32,768 Hz Low Speed crystal oscillator

IRC8M: Internal 8 MHz RC oscillator

IRC40K: Internal 40 KHz RC oscillator

IRC48M: Internal 48 MHz RC oscillator

2.6. Pin definitions

Notes:

For GD32A103Rx LQFP64, GD32A103Cx LQFP48 and GD32A103Tx QFN36, V_{REFN} and V_{REFP} are internally connected to V_{SSA} and V_{DDA} respectively.

2.6.1. GD32A103Vx LQFP100 pin definitions

Table 2-3. GD32A103Vx LQFP100 pin definitions

| GD32A103Vx LQFP100 | | | | |
|--------------------|------|-------------------------|--------------------------|--|
| Pin Name | Pins | Pin Type ⁽¹⁾ | I/O Level ⁽²⁾ | Functions description |
| PE2 | 1 | I/O | 5VT | Default: PE2 Alternate: EXMC_A23 |
| PE3 | 2 | I/O | 5VT | Default: PE3 Alternate: EXMC_A19 |
| PE4 | 3 | I/O | 5VT | Default: PE4 Alternate: EXMC_A20 |
| PE5 | 4 | I/O | 5VT | Default: PE5 Alternate: EXMC_A21 Remap: TIMER8_CH0 |
| PE6 | 5 | I/O | 5VT | Default: PE6 Alternate: EXMC_A22 Remap: TIMER8_CH1 |
| V _{BAT} | 6 | P | - | Default: V _{BAT} |
| PC13-TAMPER-RTC | 7 | I/O | - | Default: PC13 Alternate: RTC_TAMPER |
| PC14-OSC32IN | 8 | I/O | - | Default: PC14 Alternate: OSC32IN |
| PC15-OSC32OUT | 9 | I/O | - | Default: PC15 Alternate: OSC32OUT |
| V _{SS_5} | 10 | P | - | Default: V _{SS_5} |
| V _{DD_5} | 11 | P | - | Default: V _{DD_5} |
| OSCIN | 12 | I | - | Default: OSCIN Remap: PD0 |
| OSCOUT | 13 | O | - | Default: OSCOUT Remap: PD1 |
| NRST | 14 | I/O | - | Default: NRST |
| PC0 | 15 | I/O | - | Default: PC0 Alternate: ADC01_IN10 |
| PC1 | 16 | I/O | - | Default: PC1 Alternate: ADC01_IN11 |
| PC2 | 17 | I/O | - | Default: PC2 Alternate: ADC01_IN12 |
| PC3 | 18 | I/O | - | Default: PC3 Alternate: ADC01_IN13 |
| V _{SSA} | 19 | P | - | Default: V _{SSA} |

| GD32A103Vx LQFP100 | | | | |
|--------------------|------|-------------------------|--------------------------|---|
| Pin Name | Pins | Pin Type ⁽¹⁾ | I/O Level ⁽²⁾ | Functions description |
| V _{REFN} | 20 | P | - | Default: V _{REFN} |
| V _{REFP} | 21 | P | - | Default: V _{REFP} |
| V _{DDA} | 22 | P | - | Default: V _{DDA} |
| PA0-WKUP | 23 | I/O | - | Default: PA0 Alternate: WKUP, USART1_CTS, ADC01_IN0, TIMER1_CH0, TIMER1_ETI, TIMER4_CH0, TIMER7_ETI |
| PA1 | 24 | I/O | - | Default: PA1 Alternate: USART1_RTS, ADC01_IN1, TIMER4_CH1, TIMER1_CH1 |
| PA2 | 25 | I/O | - | Default: PA2 Alternate: USART1_TX, TIMER4_CH2, ADC01_IN2, TIMER8_CH0, TIMER1_CH2, SPI0_IO2 |
| PA3 | 26 | I/O | - | Default: PA3 Alternate: USART1_RX, TIMER4_CH3, ADC01_IN3, TIMER1_CH3, TIMER8_CH1, SPI0_IO3 |
| V _{SS_4} | 27 | P | - | Default: V _{SS_4} |
| V _{DD_4} | 28 | P | - | Default: V _{DD_4} |
| PA4 | 29 | I/O | - | Default: PA4 Alternate: SPI0_NSS, USART1_CK, DAC_OUT0, ADC01_IN4 Remap: SPI2_NSS, I2S2_WS |
| PA5 | 30 | I/O | - | Default: PA5 Alternate: SPI0_SCK, ADC01_IN5, DAC_OUT1 |
| PA6 | 31 | I/O | - | Default: PA6 Alternate: SPI0_MISO, TIMER7_BRKIN, ADC01_IN6, TIMER2_CH0, TIMER12_CH0 Remap: TIMER0_BRKIN |
| PA7 | 32 | I/O | - | Default: PA7 Alternate: SPI0_MOSI, TIMER7_CH0_ON, ADC01_IN7, TIMER2_CH1, TIMER13_CH0 Remap: TIMER0_CH0_ON |
| PC4 | 33 | I/O | - | Default: PC4 Alternate: ADC01_IN14 |
| PC5 | 34 | I/O | - | Default: PC5 Alternate: ADC01_IN15 |
| PB0 | 35 | I/O | - | Default: PB0 Alternate: ADC01_IN8, TIMER2_CH2, TIMER7_CH1_ON Remap: TIMER0_CH1_ON |

| GD32A103Vx LQFP100 | | | | |
|--------------------|------|-------------------------|--------------------------|---|
| Pin Name | Pins | Pin Type ⁽¹⁾ | I/O Level ⁽²⁾ | Functions description |
| PB1 | 36 | I/O | - | Default: PB1 Alternate: ADC01_IN9, TIMER2_CH3, TIMER7_CH2_ON Remap: TIMER0_CH2_ON |
| PB2 | 37 | I/O | 5VT | Default: PB2, BOOT1 |
| PE7 | 38 | I/O | 5VT | Default: PE7 Alternate: EXMC_D4 Remap: TIMER0_ETI |
| PE8 | 39 | I/O | 5VT | Default: PE8 Alternate: EXMC_D5 Remap: TIMER0_CH0_ON |
| PE9 | 40 | I/O | 5VT | Default: PE9 Alternate: EXMC_D6 Remap: TIMER0_CH0 |
| PE10 | 41 | I/O | 5VT | Default: PE10 Alternate: EXMC_D7 Remap: TIMER0_CH1_ON |
| PE11 | 42 | I/O | 5VT | Default: PE11 Alternate: EXMC_D8 Remap: TIMER0_CH1 |
| PE12 | 43 | I/O | 5VT | Default: PE12 Alternate: EXMC_D9 Remap: TIMER0_CH2_ON |
| PE13 | 44 | I/O | 5VT | Default: PE13 Alternate: EXMC_D10 Remap: TIMER0_CH2 |
| PE14 | 45 | I/O | 5VT | Default: PE14 Alternate: EXMC_D11 Remap: TIMER0_CH3 |
| PE15 | 46 | I/O | 5VT | Default: PE15 Alternate: EXMC_D12 Remap: TIMER0_BRKIN |
| PB10 | 47 | I/O | 5VT | Default: PB10 Alternate: I2C1_SCL, USART2_TX Remap: TIMER1_CH2 |
| PB11 | 48 | I/O | 5VT | Default: PB11 Alternate: I2C1_SDA, USART2_RX Remap: TIMER1_CH3 |
| V _{SS_1} | 49 | P | - | Default: V _{SS_1} |
| V _{DD_1} | 50 | P | - | Default: V _{DD_1} |

| GD32A103Vx LQFP100 | | | | |
|--------------------|------|-------------------------|--------------------------|---|
| Pin Name | Pins | Pin Type ⁽¹⁾ | I/O Level ⁽²⁾ | Functions description |
| PB12 | 51 | I/O | 5VT | Default: PB12 Alternate: SPI1_NSS, I2S1_WS, I2C1_SMBA, USART2_CK, TIMER0_BRKIN, CAN1_RX |
| PB13 | 52 | I/O | 5VT | Default: PB13 Alternate: SPI1_SCK, I2S1_CK, USART2_CTS, TIMER0_CH0_ON, CAN1_TX, I2C1_TXFRAME |
| PB14 | 53 | I/O | 5VT | Default: PB14 Alternate: SPI1_MISO, USART2_RTS, TIMER0_CH1_ON, TIMER11_CH0 |
| PB15 | 54 | I/O | 5VT | Default: PB15 Alternate: SPI1_MOSI, I2S1_SD, TIMER0_CH2_ON, TIMER11_CH1 |
| PD8 | 55 | I/O | 5VT | Default: PD8 Alternate: EXMC_D13 Remap: USART2_TX |
| PD9 | 56 | I/O | 5VT | Default: PD9 Alternate: EXMC_D14 Remap: USART2_RX |
| PD10 | 57 | I/O | 5VT | Default: PD10 Alternate: EXMC_D15 Remap: USART2_CK |
| PD11 | 58 | I/O | 5VT | Default: PD11 Alternate: EXMC_A16 Remap: USART2_CTS |
| PD12 | 59 | I/O | 5VT | Default: PD12 Alternate: EXMC_A17 Remap: TIMER3_CH0, USART2_RTS |
| PD13 | 60 | I/O | 5VT | Default: PD13 Alternate: EXMC_A18 Remap: TIMER3_CH1 |
| PD14 | 61 | I/O | 5VT | Default: PD14 Alternate: EXMC_D0 Remap: TIMER3_CH2 |
| PD15 | 62 | I/O | 5VT | Default: PD15 Alternate: EXMC_D1 Remap: TIMER3_CH3, CTC_SYNC |
| PC6 | 63 | I/O | 5VT | Default: PC6 Alternate: I2S1_MCK, TIMER7_CH0 Remap: TIMER2_CH0 |

| GD32A103Vx LQFP100 | | | | |
|--------------------|------|-------------------------|--------------------------|--|
| Pin Name | Pins | Pin Type ⁽¹⁾ | I/O Level ⁽²⁾ | Functions description |
| PC7 | 64 | I/O | 5VT | Default: PC7 Alternate: I2S2_MCK, TIMER7_CH1 Remap: TIMER2_CH1 |
| PC8 | 65 | I/O | 5VT | Default: PC8 Alternate: TIMER7_CH2 Remap: TIMER2_CH2 |
| PC9 | 66 | I/O | 5VT | Default: PC9 Alternate: TIMER7_CH3 Remap: TIMER2_CH3 |
| PA8 | 67 | I/O | 5VT | Default: PA8 Alternate: USART0_CK, TIMER0_CH0, CK_OUT0, USBFS_SOF, CTC_SYNC |
| PA9 | 68 | I/O | 5VT | Default: PA9 Alternate: USART0_TX, TIMER0_CH1, USBFS_VBUS |
| PA10 | 69 | I/O | 5VT | Default: PA10 Alternate: USART0_RX, TIMER0_CH2, USBFS_ID, V1REF |
| PA11 | 70 | I/O | 5VT | Default: PA11 Alternate: USART0_CTS, CAN0_RX, USBFS_DM, TIMER0_CH3 |
| PA12 | 71 | I/O | 5VT | Default: PA12 Alternate: USART0_RTS, CAN0_TX, USBFS_DP, TIMER0_ETI |
| PA13 | 72 | I/O | 5VT | Default: JTMS, SWDIO Remap: PA13 |
| NC | 73 | - | - | - |
| V _{SS_2} | 74 | P | - | Default: V _{SS_2} |
| V _{DD_2} | 75 | P | - | Default: V _{DD_2} |
| PA14 | 76 | I/O | 5VT | Default: JTCK, SWCLK Remap: PA14 |
| PA15 | 77 | I/O | 5VT | Default: JTDI Alternate: SPI2_NSS, I2S2_WS Remap: TIMER1_CH0, TIMER1_ETI, PA15, SPI0_NSS |
| PC10 | 78 | I/O | 5VT | Default: PC10 Alternate: UART3_TX Remap: USART2_TX, SPI2_SCK, I2S2_CK |
| PC11 | 79 | I/O | 5VT | Default: PC11 Alternate: UART3_RX Remap: USART2_RX, SPI2_MISO |

| GD32A103Vx LQFP100 | | | | |
|--------------------|------|-------------------------|--------------------------|---|
| Pin Name | Pins | Pin Type ⁽¹⁾ | I/O Level ⁽²⁾ | Functions description |
| PC12 | 80 | I/O | 5VT | Default: PC12 Alternate: UART4_TX Remap: USART2_CK, SPI2_MOSI, I2S2_SD |
| PD0 | 81 | I/O | 5VT | Default: PD0 Alternate: EXMC_D2 Remap: OSCIN, CAN0_RX |
| PD1 | 82 | I/O | 5VT | Default: PD1 Alternate: EXMC_D3 Remap: OSCOUT, CAN0_TX |
| PD2 | 83 | I/O | 5VT | Default: PD2 Alternate: TIMER2_ETI, UART4_RX |
| PD3 | 84 | I/O | 5VT | Default: PD3 Alternate: EXMC_CLK Remap: USART1_CTS |
| PD4 | 85 | I/O | 5VT | Default: PD4 Alternate: EXMC_NOE Remap: USART1_RTS |
| PD5 | 86 | I/O | 5VT | Default: PD5 Alternate: EXMC_NWE Remap: USART1_TX |
| PD6 | 87 | I/O | 5VT | Default: PD6 Alternate: EXMC_NWAIT Remap: USART1_RX |
| PD7 | 88 | I/O | 5VT | Default: PD7 Alternate: EXMC_NE0 Remap: USART1_CK |
| PB3 | 89 | I/O | 5VT | Default: JTDO Alternate: SPI2_SCK, I2S2_CK Remap: TIMER1_CH1, PB3, SPI0_SCK |
| PB4 | 90 | I/O | 5VT | Default: NJTRST Alternate: SPI2_MISO, I2C0_TXFRAME Remap: TIMER2_CH0, PB4, SPI0_MISO |
| PB5 | 91 | I/O | - | Default: PB5 Alternate: I2C0_SMBA, SPI2_MOSI, I2S2_SD Remap: TIMER2_CH1, SPI0_MOSI, CAN1_RX |
| PB6 | 92 | I/O | 5VT | Default: PB6 Alternate: I2C0_SCL, TIMER3_CH0 Remap: USART0_TX, CAN1_TX, SPI0_IO2 |

| GD32A103Vx LQFP100 | | | | |
|--------------------|------|-------------------------|--------------------------|--|
| Pin Name | Pins | Pin Type ⁽¹⁾ | I/O Level ⁽²⁾ | Functions description |
| PB7 | 93 | I/O | 5VT | Default: PB7 Alternate: I2C0_SDA, TIMER3_CH1, EXMC_NL(NADV) Remap: USART0_RX, SPI0_IO3 |
| BOOT0 | 94 | I | - | Default: BOOT0 |
| PB8 | 95 | I/O | 5VT | Default: PB8 Alternate: TIMER3_CH2, TIMER9_CH0 Remap: I2C0_SCL, CAN0_RX |
| PB9 | 96 | I/O | 5VT | Default: PB9 Alternate: TIMER3_CH3, TIMER10_CH0 Remap: I2C0_SDA, CAN0_TX |
| PE0 | 97 | I/O | 5VT | Default: PE0 Alternate: TIMER3_ETI, EXMC_NBL0 |
| PE1 | 98 | I/O | 5VT | Default: PE1 Alternate: EXMC_NBL1 |
| V _{SS_3} | 99 | P | - | Default: V _{SS_3} |
| V _{DD_3} | 100 | P | - | Default: V _{DD_3} |

Notes:

1. Type: I= input, O = output, P = power.
2. I/O Level: 5VT = 5V tolerant.
3. Functions are available in GD32A103xx devices.

2.6.2. GD32A103Rx LQFP64 pin definitions

Table 2-4. GD32A103Rx LQFP64 pin definitions

| GD32A103Rx LQFP64 | | | | |
|-------------------|------|-------------------------|--------------------------|--|
| Pin Name | Pins | Pin Type ⁽¹⁾ | I/O Level ⁽²⁾ | Functions description |
| V _{BAT} | 1 | P | - | Default: V _{BAT} |
| PC13-TAMPER-RTC | 2 | I/O | - | Default: PC13 Alternate: RTC_TAMPER |
| PC14-OSC32IN | 3 | I/O | - | Default: PC14 Alternate: OSC32IN |
| PC15-OSC32OUT | 4 | I/O | - | Default: PC15 Alternate: OSC32OUT |
| PD0-OSCIN | 5 | I | - | Default: OSCIN Remap: PD0 ⁽³⁾ |
| PD1-OSCOU | 6 | O | - | Default: OSCOUT Remap: PD1 ⁽³⁾ |
| NRST | 7 | I/O | - | Default: NRST |

| GD32A103Rx LQFP64 | | | | |
|-------------------|------|-------------------------|--------------------------|--|
| Pin Name | Pins | Pin Type ⁽¹⁾ | I/O Level ⁽²⁾ | Functions description |
| PC0 | 8 | I/O | - | Default: PC0 Alternate: ADC01_IN10 |
| PC1 | 9 | I/O | - | Default: PC1 Alternate: ADC01_IN11 |
| PC2 | 10 | I/O | - | Default: PC2 Alternate: ADC01_IN12 |
| PC3 | 11 | I/O | - | Default: PC3 Alternate: ADC01_IN13 |
| V _{SSA} | 12 | P | - | Default: V _{SSA} |
| V _{DDA} | 13 | P | - | Default: V _{DDA} |
| PA0-WKUP | 14 | I/O | - | Default: PA0 Alternate: WKUP, USART1_CTS, ADC01_IN0, TIMER1_CH0, TIMER1_ETI, TIMER4_CH0, TIMER7_ETI |
| PA1 | 15 | I/O | - | Default: PA1 Alternate: USART1_RTS, ADC01_IN1, TIMER4_CH1, TIMER1_CH1 |
| PA2 | 16 | I/O | - | Default: PA2 Alternate: USART1_TX, TIMER4_CH2, ADC01_IN2, TIMER8_CH0, TIMER1_CH2, SPI0_IO2 |
| PA3 | 17 | I/O | - | Default: PA3 Alternate: USART1_RX, TIMER4_CH3, ADC01_IN3, TIMER1_CH3, TIMER8_CH1, SPI0_IO3 |
| V _{SS_4} | 18 | P | - | Default: V _{SS_4} |
| V _{DD_4} | 19 | P | - | Default: V _{DD_4} |
| PA4 | 20 | I/O | - | Default: PA4 Alternate: SPI0_NSS, USART1_CK, DAC_OUT0, ADC01_IN4 Remap: SPI2_NSS, I2S2_WS |
| PA5 | 21 | I/O | - | Default: PA5 Alternate: SPI0_SCK, ADC01_IN5, DAC_OUT1 |
| PA6 | 22 | I/O | - | Default: PA6 Alternate: SPI0_MISO, TIMER7_BRKIN, ADC01_IN6, TIMER2_CH0, TIMER12_CH0 Remap: TIMER0_BRKIN |
| PA7 | 23 | I/O | - | Default: PA7 Alternate: SPI0_MOSI, TIMER7_CH0_ON, ADC01_IN7, TIMER2_CH1, TIMER13_CH0 Remap: TIMER0_CH0_ON |
| PC4 | 24 | I/O | - | Default: PC4 Alternate: ADC01_IN14 |

| GD32A103Rx LQFP64 | | | | |
|-------------------|------|-------------------------|--------------------------|--|
| Pin Name | Pins | Pin Type ⁽¹⁾ | I/O Level ⁽²⁾ | Functions description |
| PC5 | 25 | I/O | - | Default: PC5 Alternate: ADC01_IN15 |
| PB0 | 26 | I/O | - | Default: PB0 Alternate: ADC01_IN8, TIMER2_CH2, TIMER7_CH1_ON Remap: TIMER0_CH1_ON |
| PB1 | 27 | I/O | - | Default: PB1 Alternate: ADC01_IN9, TIMER2_CH3, TIMER7_CH2_ON Remap: TIMER0_CH2_ON |
| PB2 | 28 | I/O | 5VT | Default: PB2, BOOT1 |
| PB10 | 29 | I/O | 5VT | Default: PB10 Alternate: I2C1_SCL, USART2_TX Remap: TIMER1_CH2 |
| PB11 | 30 | I/O | 5VT | Default: PB11 Alternate: I2C1_SDA, USART2_RX Remap: TIMER1_CH3 |
| V _{SS_1} | 31 | P | - | Default: V _{SS_1} |
| V _{DD_1} | 32 | P | - | Default: V _{DD_1} |
| PB12 | 33 | I/O | 5VT | Default: PB12 Alternate: SPI1_NSS, I2S1_WS, I2C1_SMBA, USART2_CK, TIMER0_BRKIN, CAN1_RX |
| PB13 | 34 | I/O | 5VT | Default: PB13 Alternate: SPI1_SCK, I2S1_CK, USART2_CTS, TIMER0_CH0_ON, CAN1_TX, I2C1_TXFRAME |
| PB14 | 35 | I/O | 5VT | Default: PB14 Alternate: SPI1_MISO, USART2_RTS, TIMER0_CH1_ON, TIMER11_CH0 |
| PB15 | 36 | I/O | 5VT | Default: PB15 Alternate: SPI1_MOSI, I2S1_SD, TIMER0_CH2_ON, TIMER11_CH1 |
| PC6 | 37 | I/O | 5VT | Default: PC6 Alternate: I2S1_MCK, TIMER7_CH0 Remap: TIMER2_CH0 |
| PC7 | 38 | I/O | 5VT | Default: PC7 Alternate: I2S2_MCK, TIMER7_CH1 Remap: TIMER2_CH1 |
| PC8 | 39 | I/O | 5VT | Default: PC8 Alternate: TIMER7_CH2 Remap: TIMER2_CH2 |
| PC9 | 40 | I/O | 5VT | Default: PC9 Alternate: TIMER7_CH3 |

| GD32A103Rx LQFP64 | | | | |
|-------------------|------|-------------------------|--------------------------|--|
| Pin Name | Pins | Pin Type ⁽¹⁾ | I/O Level ⁽²⁾ | Functions description |
| | | | | Remap: TIMER2_CH3 |
| PA8 | 41 | I/O | 5VT | Default: PA8 Alternate: USART0_CK, TIMER0_CH0, CK_OUT0, USBFS_SOF, CTC_SYNC |
| PA9 | 42 | I/O | 5VT | Default: PA9 Alternate: USART0_TX, TIMER0_CH1, USBFS_VBUS |
| PA10 | 43 | I/O | 5VT | Default: PA10 Alternate: USART0_RX, TIMER0_CH2, USBFS_ID, V1REF |
| PA11 | 44 | I/O | 5VT | Default: PA11 Alternate: USART0_CTS, CAN0_RX, USBFS_DM, TIMER0_CH3 |
| PA12 | 45 | I/O | 5VT | Default: PA12 Alternate: USART0_RTS, CAN0_TX, USBFS_DP, TIMER0_ETI |
| PA13 | 46 | I/O | 5VT | Default: JTMS, SWDIO Remap: PA13 |
| V _{SS_2} | 47 | P | - | Default: V _{SS_2} |
| V _{DD_2} | 48 | P | - | Default: V _{DD_2} |
| PA14 | 49 | I/O | 5VT | Default: JTCK, SWCLK Remap: PA14 |
| PA15 | 50 | I/O | 5VT | Default: JTDI Alternate: SPI2_NSS, I2S2_WS Remap: TIMER1_CH0, TIMER1_ETI, TIMER1_ETI, PA15, SPI0_NSS |
| PC10 | 51 | I/O | 5VT | Default: PC10 Alternate: UART3_TX Remap: USART2_TX, SPI2_SCK, I2S2_CK |
| PC11 | 52 | I/O | 5VT | Default: PC11 Alternate: UART3_RX Remap: USART2_RX, SPI2_MISO |
| PC12 | 53 | I/O | 5VT | Default: PC12 Alternate: UART4_TX Remap: USART2_CK, SPI2_MOSI, I2S2_SD |
| PD2 | 54 | I/O | 5VT | Default: PD2 Alternate: TIMER2_ETI, UART4_RX |
| PB3 | 55 | I/O | 5VT | Default: JTDO Alternate: SPI2_SCK, I2S2_CK Remap: TIMER1_CH1, PB3, SPI0_SCK |
| PB4 | 56 | I/O | 5VT | Default: NJTRST Alternate: SPI2_MISO, I2C0_TXFRAME |

| GD32A103Rx LQFP64 | | | | |
|-------------------|------|-------------------------|--------------------------|---|
| Pin Name | Pins | Pin Type ⁽¹⁾ | I/O Level ⁽²⁾ | Functions description |
| | | | | Remap: TIMER2_CH0, PB4, SPI0_MISO |
| PB5 | 57 | I/O | - | Default: PB5 Alternate: I2C0_SMBA, SPI2_MOSI, I2S2_SD Remap: TIMER2_CH1, SPI0_MOSI, CAN1_RX |
| PB6 | 58 | I/O | 5VT | Default: PB6 Alternate: I2C0_SCL, TIMER3_CH0 Remap: USART0_TX, CAN1_TX, SPI0_IO2 |
| PB7 | 59 | I/O | 5VT | Default: PB7 Alternate: I2C0_SDA, TIMER3_CH1 Remap: USART0_RX, SPI0_IO3 |
| BOOT0 | 60 | I | - | Default: BOOT0 |
| PB8 | 61 | I/O | 5VT | Default: PB8 Alternate: TIMER3_CH2, TIMER9_CH0 Remap: I2C0_SCL, CAN0_RX |
| PB9 | 62 | I/O | 5VT | Default: PB9 Alternate: TIMER3_CH3, TIMER10_CH0 Remap: I2C0_SDA, CAN0_TX |
| V _{SS_3} | 63 | P | - | Default: V _{SS_3} |
| V _{DD_3} | 64 | P | - | Default: V _{DD_3} |

Notes:

1. Type: I= input, O = output, P = power.
2. I/O Level: 5VT = 5V tolerant.
3. PD0/PD1 cannot be used for EXTI in this package.

2.6.3. GD32A103Cx LQFP48 pin definitions

Table 2-5. GD32A103Cx LQFP48 pin definitions

| GD32A103Cx LQFP48 | | | | |
|-------------------|------|-------------------------|--------------------------|---|
| Pin Name | Pins | Pin Type ⁽¹⁾ | I/O Level ⁽²⁾ | Functions description |
| V _{BAT} | 1 | P | - | Default: V _{BAT} |
| PC13-TAMPER-RTC | 2 | I/O | - | Default: PC13 Alternate: RTC_TAMPER |
| PC14-OSC32IN | 3 | I/O | - | Default: PC14 Alternate: OSC32IN |
| PC15-OSC32OUT | 4 | I/O | - | Default: PC15 Alternate: OSC32OUT |
| PD0-OSCIN | 5 | I | - | Default: OSCIN Remap: PD0 ⁽³⁾ |

| GD32A103Cx LQFP48 | | | | |
|-------------------|------|-------------------------|--------------------------|--|
| Pin Name | Pins | Pin Type ⁽¹⁾ | I/O Level ⁽²⁾ | Functions description |
| PD1-OSCOUT | 6 | O | - | Default: OSCOUT Remap: PD1 ⁽³⁾ |
| NRST | 7 | I/O | - | Default: NRST |
| V _{SSA} | 8 | P | - | Default: V _{SSA} |
| V _{DDA} | 9 | P | - | Default: V _{DDA} |
| PA0-WKUP | 10 | I/O | - | Default: PA0 Alternate: WKUP, USART1_CTS, ADC01_IN0, TIMER1_CH0, TIMER1_ETI, TIMER4_CH0 |
| PA1 | 11 | I/O | - | Default: PA1 Alternate: USART1_RTS, ADC01_IN1, TIMER4_CH1, TIMER1_CH1 |
| PA2 | 12 | I/O | - | Default: PA2 Alternate: USART1_TX, TIMER4_CH2, ADC01_IN2, TIMER8_CH0, TIMER1_CH2, SPI0_IO2 |
| PA3 | 13 | I/O | - | Default: PA3 Alternate: USART1_RX, TIMER4_CH3, ADC01_IN3, TIMER1_CH3, TIMER8_CH1, SPI0_IO3 |
| PA4 | 14 | I/O | - | Default: PA4 Alternate: SPI0_NSS, USART1_CK, DAC_OUT0, ADC01_IN4 Remap: SPI2_NSS, I2S2_WS |
| PA5 | 15 | I/O | - | Default: PA5 Alternate: SPI0_SCK, ADC01_IN5, DAC_OUT1 |
| PA6 | 16 | I/O | - | Default: PA6 Alternate: SPI0_MISO, ADC01_IN6, TIMER2_CH0, TIMER12_CH0 Remap: TIMER0_BRKIN |
| PA7 | 17 | I/O | - | Default: PA7 Alternate: SPI0_MOSI, ADC01_IN7, TIMER2_CH1, TIMER13_CH0 Remap: TIMER0_CH0_ON |
| PB0 | 18 | I/O | - | Default: PB0 Alternate: ADC01_IN8, TIMER2_CH2 Remap: TIMER0_CH1_ON |
| PB1 | 19 | I/O | - | Default: PB1 Alternate: ADC01_IN9, TIMER2_CH3 Remap: TIMER0_CH2_ON |
| PB2 | 20 | I/O | 5VT | Default: PB2, BOOT1 |
| PB10 | 21 | I/O | 5VT | Default: PB10 Alternate: I2C1_SCL, USART2_TX |

| GD32A103Cx LQFP48 | | | | |
|-------------------|------|-------------------------|--------------------------|--|
| Pin Name | Pins | Pin Type ⁽¹⁾ | I/O Level ⁽²⁾ | Functions description |
| | | | | Remap: TIMER1_CH2 |
| PB11 | 22 | I/O | 5VT | Default: PB11 Alternate: I2C1_SDA, USART2_RX Remap: TIMER1_CH3 |
| V _{SS_1} | 23 | P | - | Default: V _{SS_1} |
| V _{DD_1} | 24 | P | - | Default: V _{DD_1} |
| PB12 | 25 | I/O | 5VT | Default: PB12 Alternate: SPI1_NSS, I2S1_WS, I2C1_SMBA, USART2_CK, TIMER0_BRKIN, CAN1_RX |
| PB13 | 26 | I/O | 5VT | Default: PB13 Alternate: SPI1_SCK, I2S1_CK, USART2_CTS, TIMER0_CH0_ON, CAN1_TX, I2C1_TXFRAME |
| PB14 | 27 | I/O | 5VT | Default: PB14 Alternate: SPI1_MISO, USART2_RTS, TIMER0_CH1_ON, TIMER11_CH0 |
| PB15 | 28 | I/O | 5VT | Default: PB15 Alternate: SPI1_MOSI, I2S1_SD, TIMER0_CH2_ON, TIMER11_CH1 |
| PA8 | 29 | I/O | 5VT | Default: PA8 Alternate: USART0_CK, TIMER0_CH0, CK_OUT0, USBFS_SOF, CTC_SYNC |
| PA9 | 30 | I/O | 5VT | Default: PA9 Alternate: USART0_TX, TIMER0_CH1, USBFS_VBUS |
| PA10 | 31 | I/O | 5VT | Default: PA10 Alternate: USART0_RX, TIMER0_CH2, USBFS_ID, V1REF |
| PA11 | 32 | I/O | 5VT | Default: PA11 Alternate: USART0_CTS, CAN0_RX, USBFS_DM, TIMER0_CH3 |
| PA12 | 33 | I/O | 5VT | Default: PA12 Alternate: USART0_RTS, CAN0_TX, USBFS_DP, TIMER0_ETI |
| PA13 | 34 | I/O | 5VT | Default: JTMS, SWDIO Remap: PA13 |
| V _{SS_2} | 35 | P | - | Default: V _{SS_2} |
| V _{DD_2} | 36 | P | - | Default: V _{DD_2} |
| PA14 | 37 | I/O | 5VT | Default: JTCK, SWCLK Remap: PA14 |
| PA15 | 38 | I/O | 5VT | Default: JTDI Alternate: SPI2_NSS, I2S2_WS |

| GD32A103Cx LQFP48 | | | | |
|-------------------|------|-------------------------|--------------------------|---|
| Pin Name | Pins | Pin Type ⁽¹⁾ | I/O Level ⁽²⁾ | Functions description |
| | | | | Remap: TIMER1_CH0, TIMER1_ETI, TIMER1_ETI, PA15, SPI0_NSS |
| PB3 | 39 | I/O | 5VT | Default: JTDO Alternate: SPI2_SCK, I2S2_CK Remap: TIMER1_CH1, PB3, SPI0_SCK |
| PB4 | 40 | I/O | 5VT | Default: NJTRST Alternate: SPI2_MISO, I2C0_TXFRAME Remap: TIMER2_CH0, PB4, SPI0_MISO |
| PB5 | 41 | I/O | - | Default: PB5 Alternate: I2C0_SMBA, SPI2_MOSI, I2S2_SD Remap: TIMER2_CH1, SPI0_MOSI, CAN1_RX |
| PB6 | 42 | I/O | 5VT | Default: PB6 Alternate: I2C0_SCL, TIMER3_CH0 Remap: USART0_TX, CAN1_TX, SPI0_IO2 |
| PB7 | 43 | I/O | 5VT | Default: PB7 Alternate: I2C0_SDA, TIMER3_CH1 Remap: USART0_RX, SPI0_IO3 |
| BOOT0 | 44 | I | - | Default: BOOT0 |
| PB8 | 45 | I/O | 5VT | Default: PB8 Alternate: TIMER3_CH2, TIMER9_CH0 Remap: I2C0_SCL, CAN0_RX |
| PB9 | 46 | I/O | 5VT | Default: PB9 Alternate: TIMER3_CH3, TIMER10_CH0 Remap: I2C0_SDA, CAN0_TX |
| V _{SS_3} | 47 | P | - | Default: V _{SS_3} |
| V _{DD_3} | 48 | P | - | Default: V _{DD_3} |

Notes:

1. Type: I= input, O = output, P = power.
2. I/O Level: 5VT = 5V tolerant.
3. PD0/PD1 cannot be used for EXTI in this package.

2.6.4. GD32A103Tx QFN36 pin definitions

Table 2-6. GD32A103Tx QFN36 pin definitions

| GD32A103Tx QFN36 | | | | |
|------------------|------|-------------------------|--------------------------|---|
| Pin Name | Pins | Pin Type ⁽¹⁾ | I/O Level ⁽²⁾ | Functions description |
| PD0-OSCIN | 2 | I | - | Default: OSCIN Remap: PD0 ⁽³⁾ |
| PD1-OSCOUT | 3 | O | - | Default: OSCOUT |

| GD32A103Tx QFN36 | | | | |
|-------------------|------|-------------------------|--------------------------|--|
| Pin Name | Pins | Pin Type ⁽¹⁾ | I/O Level ⁽²⁾ | Functions description |
| | | | | Remap: PD1 ⁽³⁾ |
| NRST | 4 | I/O | - | Default: NRST |
| V _{SSA} | 5 | P | - | Default: V _{SSA} |
| V _{DDA} | 6 | P | - | Default: V _{DDA} |
| PA0-WKUP | 7 | I/O | - | Default: PA0 Alternate: WKUP, USART1_CTS, ADC01_IN0, TIMER1_CH0, TIMER1_ETI, TIMER4_CH0 |
| PA1 | 8 | I/O | - | Default: PA1 Alternate: USART1_RTS, ADC01_IN1, TIMER4_CH1, TIMER1_CH1 |
| PA2 | 9 | I/O | - | Default: PA2 Alternate: USART1_TX, TIMER4_CH2, ADC01_IN2, TIMER1_CH2, SPI0_IO2 |
| PA3 | 10 | I/O | - | Default: PA3 Alternate: USART1_RX, TIMER4_CH3, ADC01_IN3, TIMER1_CH3, SPI0_IO3 |
| PA4 | 11 | I/O | - | Default: PA4 Alternate: SPI0_NSS, USART1_CK, DAC_OUT0, ADC01_IN4 |
| PA5 | 12 | I/O | - | Default: PA5 Alternate: SPI0_SCK, ADC01_IN5, DAC_OUT1 |
| PA6 | 13 | I/O | - | Default: PA6 Alternate: SPI0_MISO, ADC01_IN6, TIMER2_CH0 Remap: TIMER0_BRKIN |
| PA7 | 14 | I/O | - | Default: PA7 Alternate: SPI0_MOSI, ADC01_IN7, TIMER2_CH1 Remap: TIMER0_CH0_ON |
| PB0 | 15 | I/O | - | Default: PB0 Alternate: ADC01_IN8, TIMER2_CH2 Remap: TIMER0_CH1_ON |
| PB1 | 16 | I/O | - | Default: PB1 Alternate: ADC01_IN9, TIMER2_CH3 Remap: TIMER0_CH2_ON |
| PB2 | 17 | I/O | 5VT | Default: PB2, BOOT1 |
| V _{SS_1} | 18 | P | - | Default: V _{SS_1} |
| V _{DD_1} | 19 | P | - | Default: V _{DD_1} |
| PA8 | 20 | I/O | 5VT | Default: PA8 Alternate: USART0_CK, TIMER0_CH0, CK_OUT0, USBFS_SOF, CTC_SYNC |
| PA9 | 21 | I/O | 5VT | Default: PA9 |

| GD32A103Tx QFN36 | | | | |
|-------------------|------|-------------------------|--------------------------|--|
| Pin Name | Pins | Pin Type ⁽¹⁾ | I/O Level ⁽²⁾ | Functions description |
| | | | | Alternate: USART0_TX, TIMER0_CH1, USBFS_VBUS |
| PA10 | 22 | I/O | 5VT | Default: PA10 Alternate: USART0_RX, TIMER0_CH2, USBFS_ID, V1REF |
| PA11 | 23 | I/O | 5VT | Default: PA11 Alternate: USART0_CTS, CAN0_RX, USBFS_DM, TIMER0_CH3 |
| PA12 | 24 | I/O | 5VT | Default: PA12 Alternate: USART0_RTS, CAN0_TX, USBFS_DP, TIMER0_ETI |
| PA13 | 25 | I/O | 5VT | Default: JTMS, SWDIO Remap: PA13 |
| V _{SS_2} | 26 | P | - | Default: V _{SS_2} |
| V _{DD_2} | 27 | P | - | Default: V _{DD_2} |
| PA14 | 28 | I/O | 5VT | Default: JTCK, SWCLK Remap: PA14 |
| PA15 | 29 | I/O | 5VT | Default: JTDI Remap: TIMER1_CH0, TIMER1_ETI, TIMER1_ETI, PA15, SPI0_NSS |
| PB3 | 30 | I/O | 5VT | Default: JTDO Remap: TIMER1_CH1, PB3, SPI0_SCK |
| PB4 | 31 | I/O | 5VT | Default: NJTRST Alternate: I2C0_TXFRAME Remap: TIMER2_CH0, PB4, SPI0_MISO |
| PB5 | 32 | I/O | - | Default: PB5 Alternate: I2C0_SMBA Remap: TIMER2_CH1, SPI0_MOSI, CAN1_RX |
| PB6 | 33 | I/O | 5VT | Default: PB6 Alternate: I2C0_SCL, TIMER3_CH0 Remap: USART0_TX, CAN1_TX, SPI0_IO2 |
| PB7 | 34 | I/O | 5VT | Default: PB7 Alternate: I2C0_SDA, TIMER3_CH1 Remap: USART0_RX, SPI0_IO3 |
| BOOT0 | 35 | I | - | Default: BOOT0 |
| V _{SS_3} | 36 | P | - | Default: V _{SS_3} |
| V _{DD_3} | 1 | P | - | Default: V _{DD_3} |

Notes:

1. Type: I= input, O = output, P = power.
2. I/O Level: 5VT = 5V tolerant.

3. PD0/PD1 cannot be used for EXTI in this package.

3. Functional description

3.1. Arm® Cortex®-M4 core

The Arm® Cortex®-M4 processor is a high performance embedded processor with DSP instructions which allow efficient signal processing and complex algorithm execution. It brings an efficient, easy-to-use blend of control and signal processing capabilities to meet the digital signal control markets demand. The processor is highly configurable enabling a wide range of implementations from those requiring floating point operations, memory protection and powerful trace technology to cost sensitive devices requiring minimal area, while delivering outstanding computational performance and an advanced system response to interrupts.

32-bit Arm® Cortex®-M4 processor core

- Up to 120 MHz operation frequency
- Single-cycle multiplication and hardware divider
- Floating Point Unit (FPU)
- Integrated DSP instructions
- Integrated Nested Vectored Interrupt Controller (NVIC)
- 24-bit SysTick timer

The Cortex®-M4 processor is based on the ARMv7-M architecture and supports both Thumb and Thumb-2 instruction sets. Some system peripherals listed below are also provided by Cortex®-M4:

- Internal Bus Matrix connected with ICode bus, DCode bus, system bus, Private Peripheral Bus (PPB) and debug accesses (AHB-AP)
- Nested Vectored Interrupt Controller (NVIC)
- Flash Patch and Breakpoint (FPB)
- Data Watchpoint and Trace (DWT)
- Instrument Trace Macrocell (ITM)
- Serial Wire JTAG Debug Port (SWJ-DP)
- Trace Port Interface Unit (TPIU)

3.2. On-chip memory

- Up to 128 Kbytes of Flash memory
- Up to 32 KB of SRAM

The Arm® Cortex®-M4 processor is structured in Harvard architecture which can use separate buses to fetch instructions and load/store data. 128 Kbytes of inner Flash at most is available for storing programs and data. [Table 2-2. GD32A103xx memory map](#) shows the memory of the GD32A103xx series of devices, including Flash, SRAM, peripheral, and other pre-defined regions.

3.3. Clock, reset and supply management

- Internal 8 MHz factory-trimmed RC and external 4 to 32 MHz crystal oscillator
- Internal 48 MHz RC oscillator
- Internal 40 KHz RC calibrated oscillator and external 32.768 KHz crystal oscillator
- 1.71 to 3.6 V application supply and I/Os
- Supply Supervisor: POR (Power On Reset), PDR (Power Down Reset), and low voltage detector (LVD)

The Clock Control Unit (CCU) provides a range of oscillator and clock functions. These include internal RC oscillator and external crystal oscillator, high speed and low speed two types. Several prescalers allow the frequency configuration of the AHB and two APB domains. The maximum frequency of the two AHB domains are 120MHz. The maximum frequency of the two APB domains including APB1 is 60 MHz and APB2 is 120 MHz. See [Figure 2-6. GD32A103xx clock tree](#) for details on the clock tree.

The Reset Control Unit (RCU) controls three kinds of reset: system reset resets the processor core and peripheral IP components. Power-on reset (POR) and power-down reset (PDR) are always active, and ensures proper operation starting from 1.66V/down to 1.62V. The device remains in reset mode when V_{DD} is below a specified threshold. The embedded low voltage detector (LVD) monitors the power supply, compares it to the voltage threshold and generates an interrupt as a warning message for leading the MCU into security.

Power supply schemes:

- V_{DD} range: 1.71 to 3.6 V, external power supply for I/Os and the internal regulator. Provided externally through V_{DD} pins.
- V_{DDA} range: 1.71 to 3.6 V, external analog power supplies for ADC, reset blocks, RCs and PLL. V_{DDA} and V_{SSA} must be connected to V_{DD} and V_{SS} , respectively.
- V_{BAT} range: 1.71 to 3.6 V, power supply for RTC, external clock 32.768 KHz oscillator and backup registers (through power switch) when V_{DD} is not present.

3.4. Boot modes

At startup, boot pins are used to select one of three boot options:

- Boot from main flash memory (default)
- Boot from system memory
- Boot from on-chip SRAM

In default condition, boot from main Flash memory is selected. The boot loader is located in the internal boot ROM memory (system memory). It is used to reprogram the Flash memory by using USART0 (PA9 and PA10).

3.5. Power saving modes

The MCU supports three kinds of power saving modes to achieve even lower power consumption. They are Sleep mode, Deep-sleep mode, and Standby mode. These operating modes reduce the power consumption and allow the application to achieve the best balance between the CPU operating time, speed and power consumption.

- **Sleep mode**

In sleep mode, only the clock of CPU core is off. All peripherals continue to operate and any interrupt/event can wake up the system.

- **Deep-sleep mode**

In deep-sleep mode, all clocks in the 1.2V domain are off, and all of the high speed crystal oscillator (IRC8M, IRC48M, HXTAL) and PLL are disabled. Only the contents of SRAM and registers are retained. Any interrupt or wakeup event from EXTI lines can wake up the system from the deep-sleep mode including the 16 external lines, the RTC alarm, the LVD output, and USB wakeup. When exiting the deep-sleep mode, the IRC8M is selected as the system clock.

- **Standby mode**

In standby mode, the whole 1.2V domain is power off, the LDO is shut down, and all of IRC8M, IRC48M, HXTAL and PLL are disabled. The contents of SRAM and registers (except Backup Registers) are lost. There are four wakeup sources for the standby mode, including the external reset from NRST pin, the RTC, the FWDG reset, and the rising edge on WKUP pin.

3.6. Analog to digital converter (ADC)

- 12-bit SAR ADC's conversion rate is up to 3 MSPS
- 12-bit, 10-bit, 8-bit or 6-bit configurable resolution
- Hardware oversampling ratio adjustable from 2 to 256x improves resolution to 16-bit
- Input voltage range: V_{REFN} to V_{REFP}
- Temperature sensor

Up to two 12-bit 3 MSPS multi-channel ADCs are integrated in the device. It has a total of 18 multiplexed channels: 16 external channels, 1 channel for internal temperature sensor (V_{SENSE}), 1 channel for internal reference voltage (V_{REFINT} , $V_{REFINT} = 1.2V$). The input voltage range is from V_{REFN} to V_{REFP} . An on-chip hardware oversampling scheme improves performance while off-loading the related computational burden from the CPU. An analog watchdog block can be used to detect the channels, which are required to remain within a specific threshold window. A configurable channel management block can be used to perform conversions in single, continuous, scan or discontinuous mode to support more advanced use.

The ADC can be triggered from the events generated by the general level 0 timers (TIMERx, x=1, 2, 3) and the advanced timers (TIMER0 and TIMER7) with internal connection. The

temperature sensor can be used to generate a voltage that varies linearly with temperature. It is internally connected to the ADC_IN16 input channel which is used to convert the sensor output voltage in a digital value.

3.7. Digital to analog converter (DAC)

- 12-bit DAC with independent output channels
- 8-bit or 12-bit mode in conjunction with the DMA controller

The 12-bit buffered DAC is used to generate variable analog outputs. The DAC channels can be triggered by the timer or EXTI with DMA support. In dual DAC channel operation, conversions could be done independently or simultaneously. The maximum output value of the DAC is V_{REFP} .

3.8. DMA

- 7 channel DMA0 controller and 5 channel DMA1 controller
- Peripherals supported: Timers, ADC, SPIs, I2Cs, USARTs, DAC, I2S

The flexible general-purpose DMA controllers provide a hardware method of transferring data between peripherals and/or memory without intervention from the CPU, thereby freeing up bandwidth for other system functions. Three types of access method are supported: peripheral to memory, memory to peripheral, memory to memory.

Each channel is connected to fixed hardware DMA requests. The priorities of DMA channel requests are determined by software configuration and hardware channel number. Transfer size of source and destination are independent and configurable.

3.9. General-purpose inputs/outputs (GPIOs)

- Up to 80 fast GPIOs, all mappable on 16 external interrupt lines
- Analog input/output configurable
- Alternate function input/output configurable

There are up to 80 general purpose I/O pins (GPIO) in GD32A103xx, named PA0 ~ PA15, PB0 ~ PB15, PC0 ~ PC15, PD0 ~ PD15 and PE0 ~ PE15 to implement logic input/output functions. Each of the GPIO ports has related control and configuration registers to satisfy the requirements of specific applications. The external interrupts on the GPIO pins of the device have related control and configuration registers in the Interrupt/event controller (EXTI). The GPIO ports are pin-shared with other alternative functions (AFs) to obtain maximum flexibility on the package pins. Each of the GPIO pins can be configured by software as output (push-pull or open-drain), as input (with or without pull-up or pull-down) or as peripheral alternate function. Most of the GPIO pins are shared with digital or analog alternate functions. All GPIOs are high-current capable except for analog inputs.

3.10. Timers and PWM generation

- Two 16-bit advanced timer (TIMER0 & TIMER7), ten 16-bit general timers (TIMER1 ~ TIMER4, TIMER8 ~ TIMER13), and two 16-bit basic timer (TIMER5 & TIMER6)
- Up to 4 independent channels of PWM, output compare or input capture for each general timer and external trigger input
- 16-bit, motor control PWM advanced timer with programmable dead-time generation for output match
- Encoder interface controller with two inputs using quadrature decoder
- 24-bit SysTick timer down counter
- 2 watchdog timers (free watchdog timer and window watchdog timer)

The advanced timer (TIMER0 & TIMER7) can be used as a three-phase PWM multiplexed on 6 channels. It has complementary PWM outputs with programmable dead-time generation. It can also be used as a complete general timer. The 4 independent channels can be used for input capture, output compare, PWM generation (edge-aligned or center-aligned counting modes) and single pulse mode output. If configured as a general 16-bit timer, it has the same functions as the TIMERx timer. It can be synchronized with external signals or to interconnect with other general timers together which have the same architecture and features.

The general timer, can be used for a variety of purposes including general time, input signal pulse width measurement or output waveform generation such as a single pulse generation or PWM output, up to 4 independent channels for input capture/output compare. TIMER1 ~ TIMER4 is based on a 16-bit auto-reload up/downcounter and a 16-bit prescaler. TIMER8 ~ TIMER13 is based on a 16-bit auto-reload upcounter and a 16-bit prescaler. The general timer also supports an encoder interface with two inputs using quadrature decoder.

The basic timer, known as TIMER5 & TIMER6, are mainly used for DAC trigger generation. They can also be used as a simple 16-bit time base.

The GD32A103xx have two watchdog peripherals, free watchdog timer and window watchdog timer. They offer a combination of high safety level, flexibility of use and timing accuracy.

The free watchdog timer includes a 12-bit down-counting counter and an 8-bit prescaler. It is clocked from an independent 40 KHz internal RC and as it operates independently of the main clock, it can operate in deep-sleep and standby modes. It can be used either as a watchdog to reset the device when a problem occurs, or as a free-running timer for application timeout management.

The window watchdog timer is based on a 7-bit down counter that can be set as free-running. It can be used as a watchdog to reset the device when a problem occurs. It is clocked from the main clock. It has an early wakeup interrupt capability and the counter can be frozen in debug mode.

The SysTick timer is dedicated for OS, but could also be used as a standard down counter. It features:

- A 24-bit down counter
- Auto reload capability
- Maskable system interrupt generation when the counter reaches 0
- Programmable clock source

3.11. Real time clock (RTC)

- 32-bit up-counter with a programmable 20-bit prescaler
- Alarm function
- Interrupt and wake-up event

The real time clock is an independent timer which provides a set of continuously running counters which can be used with suitable software to provide a clock calendar function, and provides an alarm interrupt and an expected interrupt. The RTC features a 32-bit programmable counter for long-term measurement using the compare register to generate an alarm. A 20-bit prescaler is used for the time base clock and is by default configured to generate a time base of 1 second from a clock at 32.768 KHz from external crystal oscillator.

3.12. Inter-integrated circuit (I2C)

- Up to two I2C bus interfaces can support both master and slave mode with a frequency up to 1 MHz (Fast mode plus)
- Provide arbitration function, optional PEC (packet error checking) generation and checking
- Supports 7-bit and 10-bit addressing mode and general call addressing mode

The I2C interface is an internal circuit allowing communication with an external I2C interface which is an industry standard two-line serial interface used for connection to external hardware. These two serial lines are known as a serial data line (SDA) and a serial clock line (SCL). The I2C module provides several data transfer rates: up to 100 KHz of standard mode, up to 400 KHz of the fast mode and up to 1 MHz of the fast mode plus. The I2C module also has an arbitration detect function to prevent the situation where more than one master attempts to transmit data to the I2C bus at the same time. A CRC-8 calculator is also provided in I2C interface to perform packet error checking for I2C data.

3.13. Serial peripheral interface (SPI)

- Up to three SPI interfaces with a frequency of up to 30 MHz
- Support both master and slave mode
- Hardware CRC calculation and transmit automatic CRC error checking
- Quad-SPI configuration available in master mode (only in SPI0)
- SPI TI mode and NSS pulse mode supported

The SPI interface uses 4 pins, among which are the serial data input and output lines (MISO & MOSI), the clock line (SCK) and the slave select line (NSS). Both SPIs can be served by the DMA controller. The SPI interface may be used for a variety of purposes, including simplex synchronous transfers on two lines with a possible bidirectional data line or reliable communication using CRC checking.

3.14. Universal synchronous asynchronous receiver transmitter (USART)

- Up to three USARTs and two UARTs with operating frequency up to 7.5Mbits/s
- Supports both asynchronous and clocked synchronous serial communication modes
- IrDA SIR encoder and decoder support
- LIN break generation and detection
- USARTs support ISO 7816-3 compliant smart card interface

The USART (USART0, USART1 and USART2) and UART (UART3 & UART4) are used to translate data between parallel and serial interfaces, provides a flexible full duplex data exchange using synchronous or asynchronous transfer. It is also commonly used for RS-232 standard communication. The USART/UART includes a programmable baud rate generator which is capable of dividing the system clock to produce a dedicated clock for the USART transmitter and receiver. The USART/UART also supports DMA function for high speed data communication except UART4.

3.15. Inter-IC sound (I2S)

- Two I2S bus interfaces with sampling frequency from 8 KHz to 192 KHz
- Support either master or slave mode

The Inter-IC sound (I2S) bus provides a standard communication interface for digital audio applications by 3-wire serial lines. GD32A103xx contain two I2S-bus interfaces that can be operated with 16/32 bit resolution in master or slave mode, pin multiplexed with SPI1 and SPI2. The audio sampling frequency from 8 KHz to 192 KHz is supported.

3.16. Universal serial bus full-speed interface (USBFS)

- One full-speed USB Interface with frequency up to 12 Mbit/s
- Internal 48 MHz oscillator support crystal-less operation
- Internal main PLL for USB CLK compliantly

The Universal Serial Bus (USB) is a 4-wire bus with 4 bidirectional endpoints. The device controller enables 12 Mbit/s data exchange with integrated transceivers. Transaction formatting is performed by the hardware, including CRC generation and checking. It supports

device modes. The status of a completed USB transfer or error condition is indicated by status registers. An interrupt is also generated if enabled. The required precise 48 MHz clock which can be generated from the internal main PLL (the clock source must use an HXTAL crystal oscillator) or by the internal 48 MHz oscillator in automatic trimming mode that allows crystal-less operation.

3.17. Controller area network (CAN)

- Two CAN interface supports the CAN protocols version 2.0A, 2.0B, ISO11891-1:2015 and BOSCH CAN FD specification with communication frequency up to 1 Mbit/s of classic frames and 6 Mbit/s of FD frames
- Internal main PLL for CAN CLK compliantly

Controller area network (CAN) is a method for enabling serial communication in field bus. The CAN protocol has been used extensively in industrial automation and automotive applications. It can receive and transmit standard frames with 11-bit identifiers as well as extended frames with 29-bit identifiers. Each CAN has three mailboxes for transmission and two FIFOs of three message deep for reception. It also provides 28 scalable/configurable identifier filter banks for selecting the incoming messages needed and discarding the others.

3.18. External memory controller (EXMC)

- Supported external memory: SRAM, PSRAM, ROM and NOR-Flash
- Up to 16-bit data bus
- Support to interface with Motorola 6800 and Intel 8080 type LCD directly

External memory controller (EXMC) is an abbreviation of external memory controller. It is divided in to several sub-banks for external device support, each sub-bank has its own chip selection signal but at one time, only one bank can be accessed. The EXMC support code execution from external memory. The EXMC also can be configured to interface with the most common LCD module of Motorola 6800 and Intel 8080 series and reduce the system cost and complexity.

3.19. Debug mode

- Serial wire JTAG debug port (SWJ-DP)

The Arm® SWJ-DP Interface is embedded and is a combined JTAG and serial wire debug port that enables either a serial wire debug or a JTAG probe to be connected to the target.

3.20. Package and operation temperature

- LQFP100 (GD32A103Vx), LQFP64 (GD32A103Rx) and LQFP48 (GD32A103Cx) QFN36

(GD32A103Tx)

- Operation temperature range: -40°C to +105°C (industrial level)

4. Electrical characteristics

4.1. Absolute maximum ratings

The maximum ratings are the limits to which the device can be subjected without permanently damaging the device. Note that the device is not guaranteed to operate properly at the maximum ratings. Exposure to the absolute maximum rating conditions for extended periods may affect device reliability.

Table 4-1. Absolute maximum ratings⁽¹⁾⁽⁴⁾

| Symbol | Parameter | Min | Max | Unit |
|----------------------|---|-----------------|-----------------|------|
| V_{DD} | External voltage range ⁽²⁾ | $V_{SS} - 0.3$ | $V_{SS} + 3.6$ | V |
| V_{DDA} | External analog supply voltage | $V_{SSA} - 0.3$ | $V_{SSA} + 3.6$ | V |
| V_{BAT} | External battery supply voltage | $V_{SS} - 0.3$ | $V_{SS} + 3.6$ | V |
| V_{IN} | Input voltage on 5V tolerant pin ⁽³⁾ | $V_{SS} - 0.3$ | $V_{DD} + 3.6$ | V |
| | Input voltage on other I/O | $V_{SS} - 0.3$ | 3.6 | V |
| $ \Delta V_{DDX} $ | Variations between different V_{DD} power pins | — | 50 | mV |
| $ V_{SSX} - V_{SS} $ | Variations between different ground pins | — | 50 | mV |
| I_{IO} | Maximum current for GPIO pins | — | ± 25 | mA |
| T_A | Operating temperature range | -40 | +105 | °C |
| P_D | Power dissipation at $T_A = 105^\circ\text{C}$ of LQFP100 | — | 407 | mW |
| | Power dissipation at $T_A = 105^\circ\text{C}$ of LQFP64 | — | 367 | |
| | Power dissipation at $T_A = 105^\circ\text{C}$ of LQFP48 | — | 287 | |
| | Power dissipation at $T_A = 105^\circ\text{C}$ of QFN36 | — | 543 | |
| T_{STG} | Storage temperature range | -65 | +150 | °C |
| T_J | Maximum junction temperature | — | 125 | °C |

(1) Guaranteed by design, not tested in production.

(2) All main power and ground pins should be connected to an external power source within the allowable range.

(3) V_{IN} maximum value cannot exceed 5.5 V.

(4) It is recommended that V_{DD} and V_{DDA} are powered by the same source. The maximum difference between V_{DD} and V_{DDA} does not exceed 300 mV during power-up and operation.

4.2. Operating conditions characteristics

Table 4-2. DC operating conditions

| Symbol | Parameter | Conditions | Min ⁽¹⁾ | Typ | Max ⁽¹⁾ | Unit |
|-----------|------------------------------------|------------|---------------------|-----|--------------------|------|
| V_{DD} | Supply voltage | — | 1.71 | 3.3 | 3.6 | V |
| V_{DDA} | Analog supply voltage ADC not used | — | 1.71 | 3.3 | 3.6 | V |
| | Analog supply voltage ADC used | | 2.4 | 3.3 | 3.6 | |
| V_{BAT} | Battery supply voltage | — | 1.71 ⁽²⁾ | — | 3.6 | V |

(1) Guaranteed by design, not tested in production.

(2) In the application which V_{BAT} supply the backup domains, if the V_{BAT} voltage drops below the minimum value, when V_{DD} is powered on again, it is necessary to refresh the registers of backup domains and enable LXTAL

again.

Figure 4-1. Recommended power supply decoupling capacitors⁽¹⁾⁽²⁾

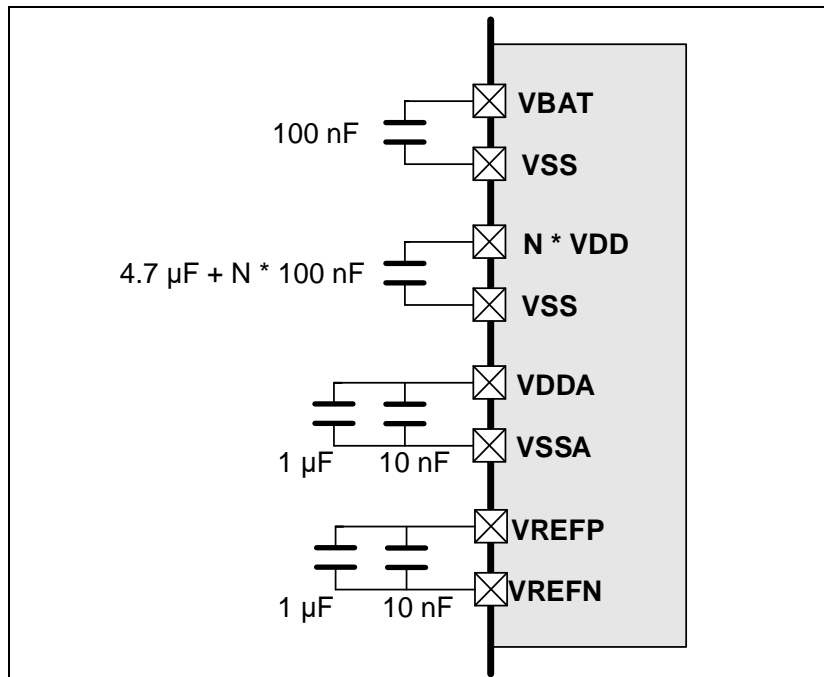

- (1) The VREFP and VREFN pins are only available on no less than 100-pin packages, or else the VREFP and VREFN pins are not available and internally connected to VDDA and VSSA pins. More details refer to **AN061 GD32E103&GD32C103 Hardware Development Guide**.
- (2) All decoupling capacitors need to be as close as possible to the pins on the PCB board.

Table 4-3. Clock frequency⁽¹⁾

| Symbol | Parameter | Conditions | Min | Max | Unit |
|-------------------|----------------------|------------|-----|-----|------|
| f _{HCLK} | AHB clock frequency | — | — | 120 | MHz |
| f _{APB1} | APB1 clock frequency | — | — | 60 | MHz |
| f _{APB2} | APB2 clock frequency | — | — | 120 | MHz |

- (1) Guaranteed by design, not tested in production.

Table 4-4. Operating conditions at Power up/ Power down⁽¹⁾

| Symbol | Parameter | Conditions | Min | Max | Unit |
|------------------|--------------------------------|------------|-----|-----|------|
| t _{VDD} | V _{DD} rise time rate | — | 0 | ∞ | μs/V |
| | V _{DD} fall time rate | | 20 | ∞ | |

- (1) Guaranteed by design, not tested in production.

Table 4-5. Start-up timings of Operating conditions⁽¹⁾⁽²⁾⁽³⁾

| Symbol | Parameter | Conditions | Typ | Unit |
|-----------------------|---------------|-------------------------|------|------|
| t _{start-up} | Start-up time | Clock source from HXTAL | 468 | μs |
| | | Clock source from IRC8M | 86.8 | |

- (1) Based on characterization, not tested in production.
- (2) After power-up, the start-up time is the time between the rising edge of NRST high and the first I/O instruction conversion in SystemInit function.
- (3) PLL is off.

Table 4-6. Power saving mode wakeup timings characteristics⁽¹⁾⁽²⁾

| Symbol | Parameter | Typ | Unit |
|-------------------------|---|------|---------------|
| t_{Sleep} | Wakeup from Sleep mode | 4.3 | μs |
| $t_{\text{Deep-sleep}}$ | Wakeup from Deep-sleep mode (LDO On) | 18.0 | |
| | Wakeup from Deep-sleep mode (LDO in low power mode) | 18.0 | |
| t_{Standby} | Wakeup from Standby mode | 82.0 | |

(1) Based on characterization, not tested in production.

(2) The wakeup time is measured from the wakeup event to the point at which the application code reads the first instruction under the below conditions: $V_{\text{DD}} = V_{\text{DDA}} = 3.3 \text{ V}$, IRC8M = System clock = 8 MHz.

4.3. Power consumption

The power measurements specified in the tables represent that code with data executing from on-chip Flash with the following specifications.

Table 4-7. Power consumption characteristics⁽²⁾⁽³⁾⁽⁴⁾⁽⁵⁾⁽⁶⁾

| Symbol | Parameter | Conditions | Min | Typ ⁽¹⁾ | Max | Unit |
|--------------------------------|---------------------------|---|-----|--------------------|-----|------|
| $I_{\text{DD}}+I_{\text{DDA}}$ | Supply current (Run mode) | $V_{\text{DD}} = V_{\text{DDA}} = 3.3 \text{ V}$, HXTAL = 25 MHz, System clock=120 MHz, All peripherals enabled | — | 28.1 | — | mA |
| | | $V_{\text{DD}} = V_{\text{DDA}} = 3.3 \text{ V}$, HXTAL = 25 MHz, System clock = 120 MHz, All peripherals disabled | — | 16.0 | — | mA |
| | | $V_{\text{DD}} = V_{\text{DDA}} = 3.3 \text{ V}$, HXTAL = 25 MHz, System clock = 108 MHz, All peripherals enabled | — | 24.6 | — | mA |
| | | $V_{\text{DD}} = V_{\text{DDA}} = 3.3 \text{ V}$, HXTAL = 25 MHz, System clock = 108 MHz, All peripherals disabled | — | 14.7 | — | mA |
| | | $V_{\text{DD}} = V_{\text{DDA}} = 3.3 \text{ V}$, HXTAL = 25 MHz, System clock = 96 MHz, All peripherals enabled | — | 22.3 | — | mA |
| | | $V_{\text{DD}} = V_{\text{DDA}} = 3.3 \text{ V}$, HXTAL = 25 MHz, System clock = 96 MHz, All peripherals disabled | — | 13.6 | — | mA |
| | | $V_{\text{DD}} = V_{\text{DDA}} = 3.3 \text{ V}$, HXTAL = 25 MHz, System clock = 72 MHz, All peripherals enabled | — | 17.2 | — | mA |
| | | $V_{\text{DD}} = V_{\text{DDA}} = 3.3 \text{ V}$, HXTAL = 25 MHz, System clock = 72 MHz, All peripherals disabled | — | 10.8 | — | mA |
| | | $V_{\text{DD}} = V_{\text{DDA}} = 3.3 \text{ V}$, HXTAL = 25 MHz, System clock = 48 MHz, All peripherals enabled | — | 12.3 | — | mA |

| Symbol | Parameter | Conditions | Min | Typ ⁽¹⁾ | Max | Unit |
|--------|--------------------------------|--|-----|--------------------|-----|------|
| | | V _{DD} = V _{DDA} = 3.3 V, HXTAL = 25 MHz, System clock = 48 MHz, All peripherals disabled | — | 8.1 | — | mA |
| | | V _{DD} = V _{DDA} = 3.3 V, HXTAL = 25 MHz, System clock = 36 MHz, All peripherals enabled | — | 9.8 | — | mA |
| | | V _{DD} = V _{DDA} = 3.3 V, HXTAL = 25 MHz, System clock = 36 MHz, All peripherals disabled | — | 6.7 | — | mA |
| | | V _{DD} = V _{DDA} = 3.3 V, HXTAL = 25 MHz, System clock = 24 MHz, All peripherals enabled | — | 7.4 | — | mA |
| | | V _{DD} = V _{DDA} = 3.3 V, HXTAL = 25 MHz, System clock = 24 MHz, All peripherals disabled | — | 5.3 | — | mA |
| | | V _{DD} = V _{DDA} = 3.3 V, HXTAL = 25 MHz, System clock = 16 MHz, All peripherals enabled | — | 5.7 | — | mA |
| | | V _{DD} = V _{DDA} = 3.3 V, HXTAL = 25 MHz, System clock = 16 MHz, All peripherals disabled | — | 4.4 | — | mA |
| | | V _{DD} = V _{DDA} = 3.3 V, HXTAL = 25 MHz, System clock = 8 MHz, All peripherals enabled | — | 4.1 | — | mA |
| | | V _{DD} = V _{DDA} = 3.3 V, HXTAL = 25 MHz, System clock = 8 MHz, All peripherals disabled | — | 3.4 | — | mA |
| | | V _{DD} = V _{DDA} = 3.3 V, HXTAL = 4 MHz, System clock = 4 MHz, All peripherals enabled | — | 1.3 | — | mA |
| | | V _{DD} = V _{DDA} = 3.3 V, HXTAL = 4 MHz, System clock = 4 MHz, All peripherals disabled | — | 1.0 | — | mA |
| | | V _{DD} = V _{DDA} = 3.3 V, HXTAL = 2 MHz, System clock = 2 MHz, All peripherals enabled | — | 0.9 | — | mA |
| | | V _{DD} = V _{DDA} = 3.3 V, HXTAL = 2 MHz, System Clock = 2 MHz, All peripherals disabled | — | 0.7 | — | mA |
| | Supply current (Sleep mode) | V _{DD} = V _{DDA} = 3.3 V, HXTAL = 25 MHz, System Clock = 120 MHz, CPU clock off, All peripherals enabled | — | 20.5 | — | mA |

| Symbol | Parameter | Conditions | Min | Typ ⁽¹⁾ | Max | Unit |
|--------|-----------|---|-----|--------------------|-----|------|
| | | V _{DD} = V _{DDA} = 3.3 V, HXTAL = 25 MHz, System Clock = 120 MHz, CPU clock off, All peripherals disabled | — | 6.9 | — | mA |
| | | V _{DD} = V _{DDA} = 3.3 V, HXTAL = 25 MHz, System Clock = 108 MHz, CPU clock off, All peripherals enabled | — | 18.6 | — | mA |
| | | V _{DD} = V _{DDA} = 3.3 V, HXTAL = 25 MHz, System Clock = 108 MHz, CPU clock off, All peripherals disabled | — | 6.4 | — | mA |
| | | V _{DD} = V _{DDA} = 3.3 V, HXTAL = 25 MHz, System Clock = 96 MHz, CPU clock off, All peripherals enabled | — | 16.5 | — | mA |
| | | V _{DD} = V _{DDA} = 3.3 V, HXTAL = 25 MHz, System Clock = 96 MHz, CPU clock off, All peripherals disabled | — | 5.8 | — | mA |
| | | V _{DD} = V _{DDA} = 3.3 V, HXTAL = 25 MHz, System Clock = 72 MHz, CPU clock off, All peripherals enabled | — | 13 | — | mA |
| | | V _{DD} = V _{DDA} = 3.3 V, HXTAL = 25 MHz, System Clock = 72 MHz, CPU clock off, All peripherals disabled | — | 5 | — | mA |
| | | V _{DD} = V _{DDA} = 3.3 V, HXTAL = 25 MHz, System Clock = 48 MHz, CPU clock off, All peripherals enabled | — | 9.5 | — | mA |
| | | V _{DD} = V _{DDA} = 3.3 V, HXTAL = 25 MHz, System Clock = 48 MHz, CPU clock off, All peripherals disabled | — | 4.1 | — | mA |
| | | V _{DD} = V _{DDA} = 3.3 V, HXTAL = 25 MHz, System Clock = 36 MHz, CPU clock off, All peripherals enabled | — | 7.7 | — | mA |
| | | V _{DD} = V _{DDA} = 3.3 V, HXTAL = 25 MHz, System Clock = 36 MHz, CPU clock off, All peripherals disabled | — | 3.7 | — | mA |
| | | V _{DD} = V _{DDA} = 3.3 V, HXTAL = 25 MHz, System Clock = 24 MHz, CPU clock off, All peripherals enabled | — | 5.9 | — | mA |
| | | V _{DD} = V _{DDA} = 3.3 V, HXTAL = 25 MHz, System Clock = 24 MHz, CPU clock off, All peripherals disabled | — | 3.3 | — | mA |
| | | V _{DD} = V _{DDA} = 3.3 V, HXTAL = 25 MHz, System Clock = 16 MHz, CPU clock off, All peripherals enabled | — | 4.8 | — | mA |

| Symbol | Parameter | Conditions | Min | Typ ⁽¹⁾ | Max | Unit | |
|---|--|--|---|--------------------|------|------|----|
| | | V _{DD} = V _{DDA} = 3.3 V, HXTAL = 25 MHz, System Clock = 16 MHz, CPU clock off, All peripherals disabled | — | 3 | — | mA | |
| | | V _{DD} = V _{DDA} = 3.3 V, HXTAL = 25 MHz, System Clock = 8 MHz, CPU clock off, All peripherals enabled | — | 3.6 | — | mA | |
| | | V _{DD} = V _{DDA} = 3.3 V, HXTAL = 25 MHz, System Clock = 8 MHz, CPU clock off, All peripherals disabled | — | 2.7 | — | mA | |
| | | V _{DD} = V _{DDA} = 3.3 V, HXTAL = 4 MHz, System Clock = 4 MHz, CPU clock off, All peripherals enabled | — | 1.1 | — | mA | |
| | | V _{DD} = V _{DDA} = 3.3 V, HXTAL = 4 MHz, System Clock = 4 MHz, CPU clock off, All peripherals disabled | — | 0.6 | — | mA | |
| | | V _{DD} = V _{DDA} = 3.3 V, HXTAL = 2 MHz, System Clock = 2 MHz, CPU clock off, All peripherals enabled | — | 0.8 | — | mA | |
| | | V _{DD} = V _{DDA} = 3.3 V, HXTAL = 2 MHz, System Clock = 2 MHz, CPU clock off, All peripherals disabled | — | 0.6 | — | mA | |
| | | Supply current (Deep-Sleep mode) | V _{DD} = V _{DDA} = 3.3 V, LDO in normal power mode, IRC40K off, RTC off | — | 41.8 | 550 | μA |
| | V _{DD} = V _{DDA} = 3.3 V, LDO in low power mode, IRC40K off, RTC off | | — | 31.8 | 550 | μA | |
| | Supply current (Standby mode) | V _{DD} = V _{DDA} = 3.3 V, LXTAL off, IRC40K on, RTC on | — | 2.1 | 11 | μA | |
| | | V _{DD} = V _{DDA} = 3.3 V, LXTAL off, IRC40K on, RTC off | — | 2.0 | 11 | μA | |
| | | V _{DD} = V _{DDA} = 3.3 V, LXTAL off, IRC40K off, RTC off | — | 1.5 | 11 | μA | |
| | I _{BAT} | Battery supply current (Backup mode) | V _{DD} off, V _{DDA} off, V _{BAT} = 3.6 V, LXTAL on with external crystal, RTC on, LXTAL High driving | — | 1.6 | — | μA |
| | | | V _{DD} off, V _{DDA} off, V _{BAT} = 3.3 V, LXTAL on with external crystal, RTC on, LXTAL High driving | — | 1.4 | — | μA |
| V _{DD} off, V _{DDA} off, V _{BAT} = 2.5 V, LXTAL on with external crystal, RTC on, LXTAL High driving | | | — | 1.3 | — | μA | |

| Symbol | Parameter | Conditions | Min | Typ ⁽¹⁾ | Max | Unit |
|--------|-----------|---|-----|--------------------|-----|------|
| | | V _{DD} off, V _{DDA} off, V _{BAT} = 1.71 V, LXTAL on with external crystal, RTC on, LXTAL High driving | — | 1.2 | — | μA |
| | | V _{DD} off, V _{DDA} off, V _{BAT} = 3.6 V, LXTAL on with external crystal, RTC on, LXTAL Medium High driving | — | 1.3 | — | μA |
| | | V _{DD} off, V _{DDA} off, V _{BAT} = 3.3 V, LXTAL on with external crystal, RTC on, LXTAL Medium High driving | — | 1.1 | — | μA |
| | | V _{DD} off, V _{DDA} off, V _{BAT} = 2.5 V, LXTAL on with external crystal, RTC on, LXTAL Medium High driving | — | 1.0 | — | μA |
| | | V _{DD} off, V _{DDA} off, V _{BAT} = 1.71 V, LXTAL on with external crystal, RTC on, LXTAL Medium High driving | — | 0.9 | — | μA |
| | | V _{DD} off, V _{DDA} off, V _{BAT} = 3.6 V, LXTAL on with external crystal, RTC on, LXTAL Medium Low driving | — | 1.0 | — | μA |
| | | V _{DD} off, V _{DDA} off, V _{BAT} = 3.3 V, LXTAL on with external crystal, RTC on, LXTAL Medium Low driving | — | 0.9 | — | μA |
| | | V _{DD} off, V _{DDA} off, V _{BAT} = 2.5 V, LXTAL on with external crystal, RTC on, LXTAL Medium Low driving | — | 0.7 | — | μA |
| | | V _{DD} off, V _{DDA} off, V _{BAT} = 1.71 V, LXTAL on with external crystal, RTC on, LXTAL Medium Low driving | — | 0.6 | — | μA |
| | | V _{DD} off, V _{DDA} off, V _{BAT} = 3.6 V, LXTAL on with external crystal, RTC on, LXTAL Low driving | — | 0.9 | — | μA |
| | | V _{DD} off, V _{DDA} off, V _{BAT} = 3.3 V, LXTAL on with external crystal, RTC on, LXTAL Low driving | — | 0.8 | — | μA |
| | | V _{DD} off, V _{DDA} off, V _{BAT} = 2.5 V, LXTAL on with external crystal, RTC on, LXTAL Low driving | — | 0.6 | — | μA |
| | | V _{DD} off, V _{DDA} off, V _{BAT} = 1.71 V, LXTAL on with external crystal, RTC on, LXTAL Low driving | — | 0.5 | — | μA |

(1) Based on characterization, not tested in production.

(2) Unless otherwise specified, all values given for T_A = 25 °C and test result is mean value.

(3) When System Clock is less than 4 MHz, an external source is used, and the HXTAL bypass function is needed, no PLL.

(4) When System Clock is greater than 8 MHz, a crystal 25 MHz is used, and the HXTAL bypass function is closed, using PLL.

- (5) When analog peripheral blocks such as ADCs, DACs, HXTAL, LXTAL, IRC8M, or IRC40K are ON, an additional power consumption should be considered.
- (6) All GPIOs are configured as analog mode except standby mode.

Figure 4-2. Typical supply current consumption in Run mode

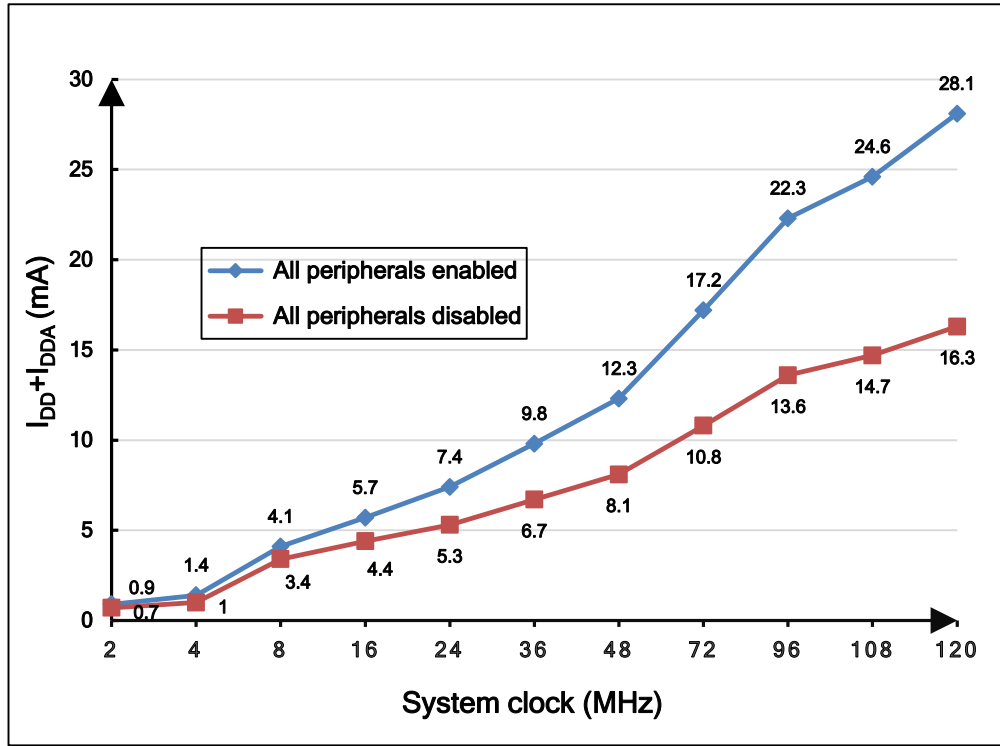

Figure 4-3. Typical supply current consumption in Sleep mode

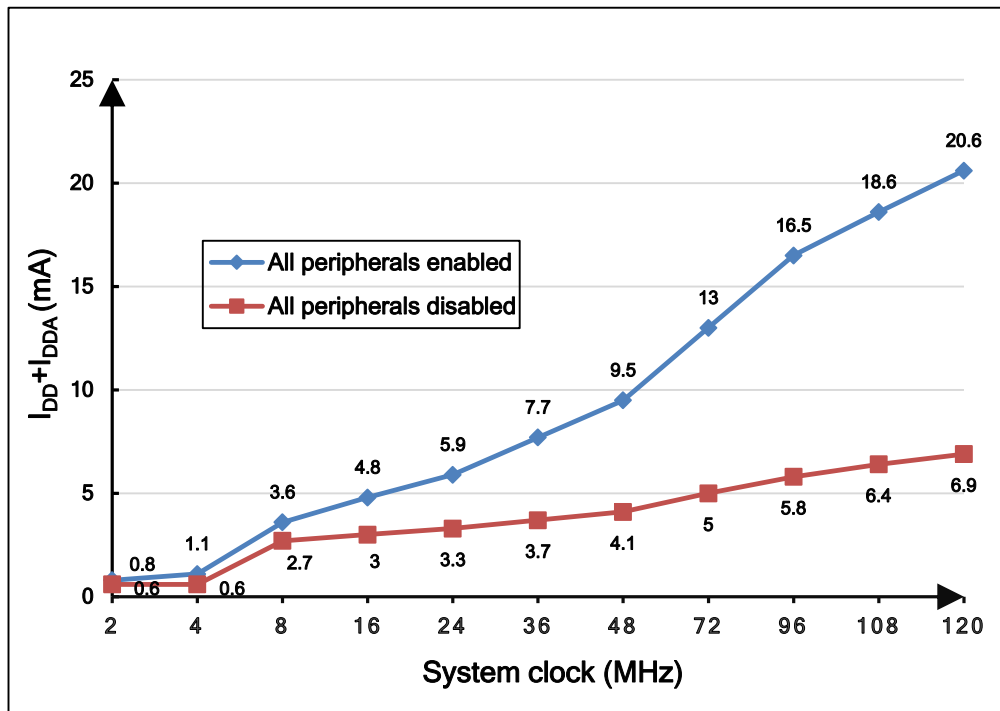

Table 4-8. Peripheral current consumption characteristics⁽¹⁾

| Peripherals ⁽⁴⁾ | | Typical consumption at 25 °C (TYP) | Unit |
|----------------------------|---------------------|------------------------------------|------|
| APB1 | DAC ⁽²⁾ | 0.44 | mA |
| | PMU | 0.18 | |
| | BKPI | 0.38 | |
| | CAN1 | 0.3 | |
| | CAN0 | 0.32 | |
| | I2C1 | 0.77 | |
| | I2C0 | 0.77 | |
| | UART4 | 0.78 | |
| | UART3 | 0.78 | |
| | USART2 | 0.78 | |
| | USART1 | 0.78 | |
| | SPI2 | 0.72 | |
| | SPI1 | 0.78 | |
| | WWDGT | 0.03 | |
| | TIMER13 | 0.32 | |
| | TIMER12 | 0.3 | |
| | TIMER11 | 0.31 | |
| | TIMER6 | 0.05 | |
| | TIMER5 | 0.04 | |
| | TIMER4 | 0.38 | |
| | TIMER3 | 0.37 | |
| TIMER2 | 0.36 | | |
| TIMER1 | 0.37 | | |
| ADDAPB1 | CTC | 0.68 | |
| APB2 | TIMER10 | 0.56 | |
| | TIMER9 | 0.58 | |
| | TIMER8 | 0.6 | |
| | USART0 | 0.52 | |
| | TIMER7 | 0.87 | |
| | SPI0 | 0.09 | |
| | TIMER0 | 0.65 | |
| | ADC1 ⁽³⁾ | 1.36 | |
| | ADC0 ⁽³⁾ | 1.35 | |
| | GPIOE | 0.18 | |
| | GIPOD | 0.19 | |
| | GPIOC | 0.2 | |
| | GPIOB | 0.18 | |
| | GPIOA | 0.19 | |
| GPIOF | 0.04 | | |
| AHB | USBFS | 1.48 | |

| Peripherals ⁽⁴⁾ | | Typical consumption at 25 °C (TYP) | Unit |
|----------------------------|------|------------------------------------|------|
| | EXMC | 0.29 | |
| | CRC | 0.03 | |
| | DMA1 | 0.31 | |
| | DMA0 | 0.39 | |

- (1) Based on characterization, not tested in production.
(2) DEN0 and DEN1 bits in the DAC_CTL register are set to 1, and the converted value set to 0x800.
(3) System clock = $f_{HCLK} = 72 \text{ MHz}$, $f_{APB1} = f_{HCLK}/2$, $f_{APB2} = f_{HCLK}$, $f_{ADCCLK} = f_{APB2}/2$, ADCON bit is set to 1.
(4) If there is no other description, then HXTAL = 25 MHz, system clock = $f_{HCLK} = 120 \text{ MHz}$, $f_{APB1} = f_{HCLK}/2$, $f_{APB2} = f_{HCLK}$.

4.4. EMC characteristics

System level ESD (Electrostatic discharge, according to IEC 61000-4-2) and EFT (Electrical Fast Transient/burst, according to IEC 61000-4-4) testing result is given in the [Table 4-9. System level ESD and EFT characteristics^{\(1\)}](#). System level ESD is for end-customer operation, it includes ESD field events on system level occur in an unprotected area (outside EPA). System level ESD protection necessary to satisfy higher ESD levels.

Table 4-9. System level ESD and EFT characteristics⁽¹⁾

| Symbol | Description | Conditions | Package | Class | Level |
|-----------|---|---|---------|-------------------|-------|
| V_{ESD} | Contact / Air mode high voltage stressed on all I/O pins | $V_{DD}=3.3 \text{ V}$, $T_J=25 \text{ }^\circ\text{C}$ $f_{HCLK} = 120 \text{ MHz}$ IEC 61000-4-2 | LQFP100 | CD 8KV AD 15KV | 4A |
| V_{EFT} | Fast transient high voltage burst stressed on Power and GND | $V_{DD}=3.3 \text{ V}$, $T_J=25 \text{ }^\circ\text{C}$ $f_{HCLK} = 120 \text{ MHz}$ IEC 61000-4-4 | LQFP100 | 4KV | 4A |

- (1) Value guaranteed by characterization, not 100% tested in production.

EMI (Electromagnetic Interference) emission test result is given in the [Table 4-10. EMI characteristics](#), The electromagnetic field emitted by the device are monitored while an application, executing EEMBC code, is running. The test is compliant with SAE J1752-3:2017 standard which specifies the test board and the pin loading.

Table 4-10. EMI characteristics⁽¹⁾

| Symbol | Parameter | Conditions | Package | Tested frequency band | Max vs. $[f_{HXTAL}/f_{HCLK}]$ | Unit |
|-----------|------------|--|---------|-----------------------|--------------------------------|---------------|
| | | | | | 8/120MHz | |
| S_{EMI} | Peak level | $V_{DD} = 3.6 \text{ V}$, $T_J=25 \text{ }^\circ\text{C}$ $f_{HCLK} = 120\text{MHz}$, conforms to SAE J1752-3:2017 | LQFP100 | 0.15 MHz to 30 MHz | -1.91 | dB μ V |
| | | | | 30 MHz to 130 MHz | 3.01 | |
| | | | | 130 MHz to 1 GHz | 4.77 | |

- (1) Value guaranteed by characterization, not 100% tested in production.

Component level ESD include HBM (Human body model, according to ANSI/ESDA/JEDEC

JS-001) and CDM (ANSI/ESDA/JEDEC JS-002), that ESD field events during manufacturing in an ESD protected area, such as PCB assembly/repair, IC assembly/test and Fab environment. The ESD protected area (EPA) has many measures, for instance ESD protective packaging, grounding person wrist strap to ground (or flooring/footwear), grounded work surface and ionizer.

Static latch-up (LU, according to JEDEC78) test is based on the two measurement methods, I/O current injection value (I-test) and power supply over-voltage value.

Table 4-11. Component level ESD and latch-up characteristics⁽¹⁾

| Symbol | Description | Conditions | Package | Max | Unit | Level |
|------------------|--|---------------------------------------|---------|----------------------------------|------|---------------|
| V _{HBM} | Human body model electrostatic discharge voltage (Any pin combination) | T _J = 25 °C JS-001-2017 | LQFP100 | ±2000 | V | Class 2 |
| V _{CDM} | Charge device model electrostatic discharge voltage (All pins) | T _J = 25 °C JS-002-2018 | LQFP100 | ±500 with corner pins ±750 | V | Class C2a |
| LU | I-test | T _A = 125 °C JESD78F | LQFP100 | ±100 | mA | Class II.A |
| | V _{supply} over voltage | | | 5.4 | V | |

- (1) All ESD testing are in conformity with AEC-Q100 Stress Test Qualification for Automotive Grade Integrated Circuits.
- (2) Device failure is defined as: "If after exposure to ESD pulses, the device does not meet the device specification requirements, which include the complete DC parametric and functional testing at room temperature and hot temperature".
- (3) Value guaranteed by characterization, not 100% tested in production.
- (4) This parameter is tested in conformity with AEC-Q100-002E.
- (5) This parameter is tested in conformity with AEC-Q100-011D.
- (6) This parameter is tested in conformity with AEC-Q100-004D.

4.5. Power supply supervisor characteristics

Table 4-12. Power supply supervisor characteristics

| Symbol | Parameter | Conditions | Min | Typ | Max | Unit |
|---------------------------------|-----------------------------------|-------------------------------|-----|------|-----|------|
| V _{LVD} ⁽¹⁾ | Low voltage Detector Threshold | LVDT<2:0> = 000(rising edge) | — | 2.07 | — | V |
| | | LVDT<2:0> = 000(falling edge) | — | 1.97 | — | |
| | | LVDT<2:0> = 001(rising edge) | — | 2.2 | — | |
| | | LVDT<2:0> = 001(falling edge) | — | 2.1 | — | |
| | | LVDT<2:0> = 010(rising edge) | — | 2.34 | — | |
| | | LVDT<2:0> = 010(falling edge) | — | 2.24 | — | |
| | | LVDT<2:0> = 011(rising edge) | — | 2.47 | — | |
| | | LVDT<2:0> = 011(falling edge) | — | 2.37 | — | |

| Symbol | Parameter | Conditions | Min | Typ | Max | Unit |
|--------------------------------------|----------------------------|-------------------------------|-----|------|-----|------|
| | | LVDT<2:0> = 100(rising edge) | — | 2.61 | — | |
| | | LVDT<2:0> = 100(falling edge) | — | 2.51 | — | |
| | | LVDT<2:0> = 101(rising edge) | — | 2.74 | — | |
| | | LVDT<2:0> = 101(falling edge) | — | 2.64 | — | |
| | | LVDT<2:0> = 110(rising edge) | — | 2.88 | — | |
| | | LVDT<2:0> = 110(falling edge) | — | 2.78 | — | |
| | | LVDT<2:0> = 111(rising edge) | — | 3.01 | — | |
| | | LVDT<2:0> = 111(falling edge) | — | 2.91 | — | |
| V _{LVDhyst} ⁽²⁾ | LVD hysteresis | — | — | 100 | — | mV |
| V _{POR} ⁽¹⁾ | Power on reset threshold | | — | 1.67 | — | V |
| V _{PDR} ⁽¹⁾ | Power down reset threshold | — | — | 1.62 | — | V |
| V _{PDRhyst} ⁽²⁾ | PDR hysteresis | | — | 40 | — | mV |
| t _{RSTTEMPO} ⁽²⁾ | Reset temporization | | — | 2 | — | ms |

(1) Based on characterization, not tested in production.

(2) Guaranteed by design, not tested in production.

4.6. External clock characteristics

Table 4-13. High speed external clock (HXTAL) generated from a crystal/ceramic characteristics

| Symbol | Parameter | Conditions | Min | Typ | Max | Unit |
|--|--|--------------------------------|-----|-----|-----|------|
| f _{HXTAL} ⁽¹⁾ | Crystal or ceramic frequency | 1.71 ≤ V _{DD} ≤ 3.6 V | 4 | 8 | 32 | MHz |
| R _F ⁽²⁾ | Feedback resistor | V _{DD} = 3.3 V | — | 400 | — | kΩ |
| C _{HXTAL} ^{(2) (3)} | Recommended matching capacitance on OSCIN and OSCOUT | — | — | 20 | 30 | pF |
| D _{ucy(HXTAL)} ⁽²⁾ | Crystal or ceramic duty cycle | — | 30 | 50 | 70 | % |
| g _m ⁽²⁾ | Oscillator transconductance | Startup | — | 25 | — | mA/V |
| I _{DD(HXTAL)} ⁽¹⁾ | Crystal or ceramic operating current | V _{DD} = 3.3 V | — | 1.1 | — | mA |
| t _{SUHXTAL} ⁽¹⁾ | Crystal or ceramic startup time | V _{DD} = 3.3 V | — | 1.8 | — | ms |

(1) Based on characterization, not tested in production.

(2) Guaranteed by design, not tested in production.

(3) C_{HXTAL1} = C_{HXTAL2} = 2*(C_{LOAD} - C_S). For C_{HXTAL1} and C_{HXTAL2}, it is recommended matching capacitance on OSCIN and OSCOUT. For C_{LOAD}, it is crystal/ceramic load capacitance, provided by the crystal or ceramic manufacturer. For C_S, it is PCB and MCU pin stray capacitance.

Table 4-14. High speed external clock characteristics (HXTAL in bypass mode)

| Symbol | Parameter | Conditions | Min | Typ | Max | Unit |
|--------------------------------------|---|---------------------------------|---------------------|-----|---------------------|------|
| $f_{\text{HXTAL_ext}}^{(1)}$ | External clock source or oscillator frequency | $V_{\text{DD}} = 3.3 \text{ V}$ | 1 | — | 50 | MHz |
| $V_{\text{HXTALH}}^{(2)}$ | OSCIN input pin high level voltage | $V_{\text{DD}} = 3.3 \text{ V}$ | $0.7 V_{\text{DD}}$ | — | V_{DD} | V |
| $V_{\text{HXTALL}}^{(2)}$ | OSCIN input pin low level voltage | | V_{SS} | — | $0.3 V_{\text{DD}}$ | V |
| $t_{\text{H/L(HXTAL)}}^{(2)}$ | OSCIN high or low time | — | 5 | — | — | ns |
| $t_{\text{R/F(HXTAL)}}^{(2)}$ | OSCIN rise or fall time | — | — | — | 10 | ns |
| $C_{\text{IN}}^{(2)}$ | OSCIN input capacitance | — | — | 5 | — | pF |
| $\text{Ducy}_{\text{(HXTAL)}}^{(2)}$ | Duty cycle | — | 40 | — | 60 | % |

(1) Based on characterization, not tested in production.

(2) Guaranteed by design, not tested in production.

Table 4-15. Low speed external clock (LXTAL) generated from a crystal/ceramic characteristics

| Symbol | Parameter | Conditions | Min | Typ | Max | Unit |
|------------------------|--|--------------------------------|-----|--------|-----|-----------------|
| $f_{LXTAL}^{(1)}$ | Crystal or ceramic frequency | $V_{DD} = 3.3\text{ V}$ | — | 32.768 | — | kHz |
| $C_{LXTAL}^{(2)(3)}$ | Recommended matching capacitance on OSC32IN and OSC32OUT | — | — | 10 | — | pF |
| $D_{ucy(LXTAL)}^{(2)}$ | Crystal or ceramic duty cycle | — | 30 | — | 70 | % |
| $g_m^{(2)}$ | Oscillator transconductance | Lower driving capability | — | 4 | — | $\mu\text{A/V}$ |
| | | Medium low driving capability | — | 6 | — | |
| | | Medium high driving capability | — | 12 | — | |
| | | Higher driving capability | — | 18 | — | |
| $I_{DDLXTAL}^{(1)}$ | Crystal or ceramic operating current | Lower driving capability | — | 0.7 | — | μA |
| | | Medium low driving capability | — | 0.8 | — | |
| | | Medium high driving capability | — | 1.1 | — | |
| | | Higher driving capability | — | 1.4 | — | |
| $t_{SULXTAL}^{(1)(4)}$ | Crystal or ceramic startup time | — | — | 1.8 | — | s |

(1) Based on characterization, not tested in production.

(2) Guaranteed by design, not tested in production.

(3) $C_{LXTAL1} = C_{LXTAL2} = 2 * (C_{LOAD} - C_S)$, For C_{LXTAL1} and C_{LXTAL2} , it is recommended matching capacitance on OSC32IN and OSC32OUT. For C_{LOAD} , it is crystal/ceramic load capacitance, provided by the crystal or ceramic manufacturer. For C_S , it is PCB and MCU pin stray capacitance.

(4) $t_{SULXTAL}$ is the startup time measured from the moment it is enabled (by software) to the 32.768 kHz oscillator stabilization flags is SET. This value varies significantly with the crystal manufacturer.

Table 4-16. Low speed external user clock characteristics (LXTAL in bypass mode)

| Symbol | Parameter | Conditions | Min | Typ | Max | Unit |
|------------------------|---|-------------------------|--------------|--------|--------------|------|
| $f_{LXTAL_ext}^{(1)}$ | External clock source or oscillator frequency | $V_{DD} = 3.3\text{ V}$ | — | 32.768 | 1000 | kHz |
| $V_{LXTALH}^{(2)}$ | OSC32IN input pin high level voltage | — | $0.7 V_{DD}$ | — | V_{DD} | V |
| $V_{LXTALL}^{(2)}$ | OSC32IN input pin low level voltage | — | V_{SS} | — | $0.3 V_{DD}$ | |
| $t_{H/L(LXTAL)}^{(2)}$ | OSC32IN high or low time | — | 450 | — | — | ns |
| $t_{R/F(LXTAL)}^{(2)}$ | OSC32IN rise or fall time | — | — | — | 50 | |
| $C_{IN}^{(2)}$ | OSC32IN input capacitance | — | — | 5 | — | pF |
| $D_{ucy(LXTAL)}^{(2)}$ | Duty cycle | — | 30 | 50 | 70 | % |

(1) Based on characterization, not tested in production.

(2) Guaranteed by design, not tested in production.

4.7. Internal clock characteristics

Table 4-17. High speed internal clock (IRC8M) characteristics

| Symbol | Parameter | Conditions | Min | Typ | Max | Unit |
|-------------------------|--|--|------|------|------|---------------|
| f_{IRC8M} | High Speed Internal Oscillator (IRC8M) frequency | $V_{DD} = V_{DDA} = 3.3\text{ V}$ | — | 8 | — | MHz |
| ACC_{IRC8M} | IRC8M oscillator Frequency accuracy, Factory-trimmed | $V_{DD} = V_{DDA} = 3.3\text{ V}$, $T_A = -40\text{ °C} \sim +105\text{ °C}^{(1)}$ | -2.5 | — | +2.5 | % |
| | | $V_{DD} = V_{DDA} = 3.3\text{ V}$, $T_A = 0\text{ °C} \sim +105\text{ °C}^{(1)}$ | -1.8 | — | +1.8 | % |
| | $V_{DD} = V_{DDA} = 3.3\text{ V}$, $T_A = 25\text{ °C}$ | -1.0 | — | +1.0 | % | |
| | IRC8M oscillator Frequency accuracy, User trimming step ⁽¹⁾ | — | — | 0.3 | — | % |
| $D_{UCY}_{IRC8M}^{(2)}$ | IRC8M oscillator duty cycle | $V_{DD} = V_{DDA} = 3.3\text{ V}$ | 45 | 50 | 55 | % |
| $I_{DDA}_{IRC8M}^{(1)}$ | IRC8M oscillator operating current | $V_{DD} = V_{DDA} = 3.3\text{ V}$, $f_{IRC8M} = 8\text{ MHz}$ | — | 110 | — | μA |
| $t_{SUI}_{IRC8M}^{(1)}$ | IRC8M oscillator startup time | $V_{DD} = V_{DDA} = 3.3\text{ V}$, $f_{IRC8M} = 8\text{ MHz}$ | — | 2 | — | μs |

(1) Based on characterization, not tested in production.

(2) Guaranteed by design, not tested in production.

Table 4-18. Low speed internal clock (IRC40K) characteristics

| Symbol | Parameter | Conditions | Min | Typ | Max | Unit |
|--------------------------|--|--|-----|------|-----|---------------|
| $f_{IRC40K}^{(1)}$ | Low Speed Internal oscillator (IRC40K) frequency | $V_{DD} = V_{DDA} = 3.3\text{ V}$, $T_A = -40\text{ °C} \sim +105\text{ °C}$ | 28 | 40 | 60 | kHz |
| $I_{DDA}_{IRC40K}^{(2)}$ | IRC40K oscillator operating current | $V_{DD} = V_{DDA} = 3.3\text{ V}$ | — | 0.42 | — | μA |
| $t_{SUI}_{IRC40K}^{(2)}$ | IRC40K oscillator startup time | $V_{DD} = V_{DDA} = 3.3\text{ V}$ | — | 110 | — | μs |

(1) Guaranteed by design, not tested in production.

(2) Based on characterization, not tested in production.

Table 4-19. High speed internal clock (IRC48M) characteristics

| Symbol | Parameter | Conditions | Min | Typ | Max | Unit |
|-----------------------|---|---|------|-----|-----|---------------|
| f_{IRC48M} | High Speed Internal Oscillator (IRC48M) frequency | $V_{DD} = V_{DDA} = 3.3 V$ | — | 48 | — | MHz |
| ACC_{IRC48M} | IRC48M oscillator Frequency accuracy, Factory-trimmed | $V_{DD} = V_{DDA} = 3.3 V$, $T_A = -40\text{ }^{\circ}\text{C} \sim +105\text{ }^{\circ}\text{C}^{(1)}$ | -4.0 | — | 5.0 | % |
| | | $V_{DD} = V_{DDA} = 3.3 V$, $T_A = 0\text{ }^{\circ}\text{C} \sim +105\text{ }^{\circ}\text{C}^{(1)}$ | -3.0 | — | 3.0 | % |
| | | $V_{DD} = V_{DDA} = 3.3 V$, $T_A = 25\text{ }^{\circ}\text{C}$ | -2.0 | — | 2.0 | % |
| | IRC48M oscillator Frequency accuracy, User trimming step ⁽¹⁾ | — | — | 0.1 | — | % |
| $Ducy_{IRC48M}^{(2)}$ | IRC48M oscillator duty cycle | $V_{DD} = V_{DDA} = 3.3 V$ | 45 | 50 | 55 | % |
| $I_{DDIRC48M}^{(1)}$ | IRC48M oscillator operating current | $V_{DD} = V_{DDA} = 3.3 V$, $f_{IRC48M} = 48\text{ MHz}$ | — | 270 | — | μA |
| $t_{SUIRC48M}^{(1)}$ | IRC48M oscillator startup time | $V_{DD} = V_{DDA} = 3.3 V$, $f_{IRC48M} = 48\text{ MHz}$ | — | 2.5 | — | μs |

(1) Based on characterization, not tested in production.

(2) Guaranteed by design, not tested in production.

4.8. PLL characteristics

Table 4-20. PLL characteristics

| Symbol | Parameter | Conditions | Min | Typ | Max | Unit |
|-------------------------|--------------------------------------|--------------------|-----|-----|-----|---------------|
| $f_{PLLIN}^{(1)}$ | PLL input clock frequency | — | 1 | 8 | 25 | MHz |
| $f_{PLLOUT}^{(2)}$ | PLL output clock frequency | — | 16 | — | 120 | MHz |
| $f_{VCO}^{(2)}$ | VCO output frequency | — | 32 | — | 240 | MHz |
| $t_{LOCK}^{(2)}$ | PLL lock time | — | — | — | 300 | μs |
| $I_{DDA}^{(1)}$ | Current consumption on V_{DDA} | VCO freq = 240 MHz | — | 350 | — | μA |
| $Jitter_{PLL}^{(1)(3)}$ | Cycle to cycle Jitter (rms) | System clock | — | 46 | — | ps |
| | Cycle to cycle Jitter (peak to peak) | | — | 463 | — | |

(1) Based on characterization, not tested in production.

(2) Guaranteed by design, not tested in production.

(3) Value given with main PLL running.

Table 4-21. PLL1/2 characteristics

| Symbol | Parameter | Conditions | Min | Typ | Max | Unit |
|--------------------|----------------------------|------------|-----|-----|-----|------|
| $f_{PLLIN}^{(1)}$ | PLL input clock frequency | — | 1 | 8 | 25 | MHz |
| $f_{PLLOUT}^{(2)}$ | PLL output clock frequency | — | 16 | — | 120 | MHz |
| $f_{VCO}^{(2)}$ | VCO output frequency | — | 32 | — | 240 | MHz |

| | | | | | | |
|-------------------------|---|--------------------|---|-----|-----|---------|
| $t_{LOCK}^{(2)}$ | PLL lock time | — | — | — | 300 | μs |
| $I_{DDA}^{(1)}$ | Current consumption on V_{DDA} | VCO freq = 240 MHz | — | 320 | — | μA |
| $Jitter_{PLL}^{(1)(3)}$ | Cycle to cycle Jitter (rms) | System clock | — | 46 | — | ps |
| | Cycle to cycle Jitter (peak to peak) | | — | 463 | — | |

- (1) Based on characterization, not tested in production.
(2) Guaranteed by design, not tested in production.
(3) Value given with main PLL running.

4.9. Memory characteristics

Table 4-22. Flash memory characteristics

| Symbol | Parameter | Conditions | Min | Typ | Max | Unit |
|--------------------|--|---|-----|-----|-----|---------|
| $PE_{CYC}^{(1)}$ | Number of guaranteed program /erase cycles before failure(Endurance) | $T_A = -40\text{ }^{\circ}C \sim +85\text{ }^{\circ}C$ | 100 | — | — | kcycles |
| $t_{RET}^{(1)}$ | Data retention time | 10k cycles at $T_A = 85\text{ }^{\circ}C$ | 10 | — | — | years |
| $t_{PROG}^{(2)}$ | Word ⁽³⁾ programming time | $T_A = -40\text{ }^{\circ}C \sim +105\text{ }^{\circ}C$ | 37 | — | 44 | μs |
| $t_{ERASE}^{(2)}$ | Page erase time | $T_A = -40\text{ }^{\circ}C \sim +105\text{ }^{\circ}C$ | 3.2 | — | 4 | ms |
| $t_{MERASE}^{(2)}$ | Mass erase time | $T_A = -40\text{ }^{\circ}C \sim +105\text{ }^{\circ}C$ | 8 | — | 10 | ms |

- (1) Based on characterization, not tested in production.
(2) Guaranteed by design, not tested in production.
(3) Word is 32 bits or 64 bits depend on PGW bit in FMC_WS register.

4.10. NRST pin characteristics

Table 4-23. NRST pin characteristics

| Symbol | Parameter | Conditions | Min | Typ | Max | Unit |
|----------------------|------------------------------------|--|--------------|-----|-----------------|------------|
| $V_{IL(NRST)}^{(1)}$ | NRST Input low level voltage | $1.8\text{ V} \leq V_{DD} = V_{DDA} \leq 3.6\text{ V}$ | -0.5 | — | $0.3 V_{DD}$ | V |
| $V_{IH(NRST)}^{(1)}$ | NRST Input high level voltage | | $0.7 V_{DD}$ | — | $V_{DD} + 0.45$ | |
| $V_{hyst}^{(1)}$ | Schmidt trigger Voltage hysteresis | — | — | 460 | — | mV |
| $R_{pu}^{(2)}$ | Pull-up equivalent resistor | — | — | 40 | — | k Ω |

- (1) Based on characterization, not tested in production.
(2) Guaranteed by design, not tested in production.

Figure 4-4. Recommended external NRST pin circuit

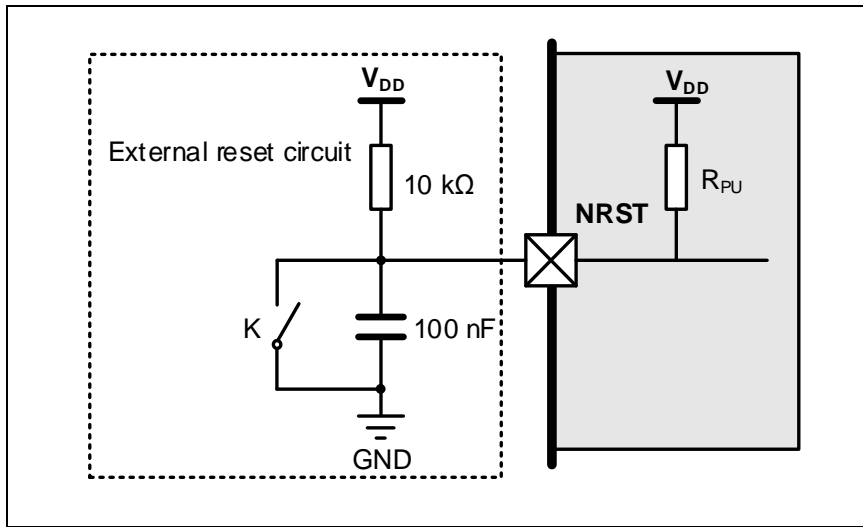

4.11. GPIO characteristics

Table 4-24. I/O port DC characteristics⁽¹⁾⁽³⁾

| Symbol | Parameter | Conditions | Min | Typ | Max | Unit |
|-----------------|---|--|---------------------|-----|---------------------|------|
| V _{IL} | Standard IO Low level input voltage | 1.8 V ≤ V _{DD} = V _{DDA} ≤ 3.6 V | — | — | 0.3 V _{DD} | V |
| | 5V-tolerant IO Low level input voltage | 1.8 V ≤ V _{DD} = V _{DDA} ≤ 3.6 V | — | — | 0.3 V _{DD} | V |
| V _{IH} | Standard IO High level input voltage | 1.8 V ≤ V _{DD} = V _{DDA} ≤ 3.6 V | 0.7 V _{DD} | — | — | V |
| | 5V-tolerant IO High level input voltage | 1.8 V ≤ V _{DD} = V _{DDA} ≤ 3.6 V | 0.7 V _{DD} | — | — | V |
| V _{OL} | Low level output voltage (I _{IO} = +8 mA) | V _{DD} = 1.8 V | — | — | 0.32 | V |
| | | V _{DD} = 2.5 V | — | — | 0.24 | |
| | | V _{DD} = 3.3 V | — | — | 0.11 | |
| | | V _{DD} = 3.6 V | — | — | 0.11 | |
| V _{OL} | Low level output voltage (I _{IO} = +20 mA) | V _{DD} = 1.8 V | — | — | 0.53 | V |
| | | V _{DD} = 2.5 V | — | — | 0.60 | |
| | | V _{DD} = 3.3 V | — | — | 0.28 | |
| | | V _{DD} = 3.6 V | — | — | 0.27 | |
| V _{OH} | High level output voltage (I _{IO} = +8 mA) | V _{DD} = 1.8 V | 1.49 | — | — | V |
| | | V _{DD} = 2.5 V | 2.27 | — | — | |
| | | V _{DD} = 3.3 V | 3.14 | — | — | |
| | | V _{DD} = 3.6 V | 3.45 | — | — | |
| V _{OH} | High level output voltage (I _{IO} = +20 mA) | V _{DD} = 1.8 V | 1.25 | — | — | V |
| | | V _{DD} = 2.5 V | 1.89 | — | — | |
| | | V _{DD} = 3.3 V | 2.91 | — | — | |

| Symbol | Parameter | Conditions | Min | Typ | Max | Unit |
|----------------|-----------------------------|-------------------------|------|-----|-----|-----------|
| | | $V_{DD} = 3.6\text{ V}$ | 3.23 | — | — | |
| $R_{PU}^{(2)}$ | Internal pull-up resistor | — | — | 40 | — | $k\Omega$ |
| $R_{PD}^{(2)}$ | Internal pull-down resistor | — | — | 40 | — | $k\Omega$ |

- (1) Based on characterization, not tested in production.
(2) Guaranteed by design, not tested in production.
(3) All pins except PC13 / PC14 / PC15. Since PC13 to PC15 are supplied through the Power Switch, which can only be obtained by a small current, the speed of GPIOs PC13 to PC15 should not exceed 2 MHz when they are in output mode(maximum load: 30 pF).

Table 4-25. I/O port AC characteristics⁽¹⁾⁽²⁾

| GPIOx_MDY[1:0] bit value ⁽³⁾ | Parameter | Conditions | Max | Unit |
|--|----------------------------------|---|-----|------|
| GPIOx_CTL->MDy[1:0] = 10 (IO_Speed = 2 MHz) | Maximum frequency ⁽⁴⁾ | $1.8 \leq V_{DD} \leq 3.6\text{ V}, C_L = 10\text{ pF}$ | 9 | MHz |
| | | $1.8 \leq V_{DD} \leq 3.6\text{ V}, C_L = 30\text{ pF}$ | 6 | |
| | | $1.8 \leq V_{DD} \leq 3.6\text{ V}, C_L = 50\text{ pF}$ | 4 | |
| GPIOx_CTL->MDy[1:0] = 01 (IO_Speed = 10 MHz) | Maximum frequency ⁽⁴⁾ | $1.8 \leq V_{DD} \leq 3.6\text{ V}, C_L = 10\text{ pF}$ | 50 | MHz |
| | | $1.8 \leq V_{DD} \leq 3.6\text{ V}, C_L = 30\text{ pF}$ | 25 | |
| | | $1.8 \leq V_{DD} \leq 3.6\text{ V}, C_L = 50\text{ pF}$ | 15 | |
| GPIOx_CTL->MDy[1:0] = 11 (IO_Speed = 50 MHz) | Maximum frequency ⁽⁴⁾ | $1.8 \leq V_{DD} \leq 3.6\text{ V}, C_L = 10\text{ pF}$ | 60 | MHz |
| | | $1.8 \leq V_{DD} \leq 3.6\text{ V}, C_L = 30\text{ pF}$ | 30 | |
| | | $1.8 \leq V_{DD} \leq 3.6\text{ V}, C_L = 50\text{ pF}$ | 20 | |
| GPIOx_CTL->MDy[1:0] = 11 and GPIOx_SPDy = 1 (IO_Speed = MAX) | Maximum frequency ⁽⁴⁾ | $1.8 \leq V_{DD} \leq 3.6\text{ V}, C_L = 10\text{ pF}$ | 70 | MHz |
| | | $1.8 \leq V_{DD} \leq 3.6\text{ V}, C_L = 30\text{ pF}$ | 50 | |
| | | $1.8 \leq V_{DD} \leq 3.6\text{ V}, C_L = 50\text{ pF}$ | 30 | |

- (1) Based on characterization, not tested in production.
(2) Unless otherwise specified, all test results given for $T_A = 25\text{ }^\circ\text{C}$.
(3) The I/O speed is configured using the GPIOx_CTL -> MDy[1:0] bits. Refer to the GD32E103xx user manual which is selected to set the GPIO port output speed.
(4) The maximum frequency is defined in [Figure 4-5. I/O port AC characteristics definition](#)

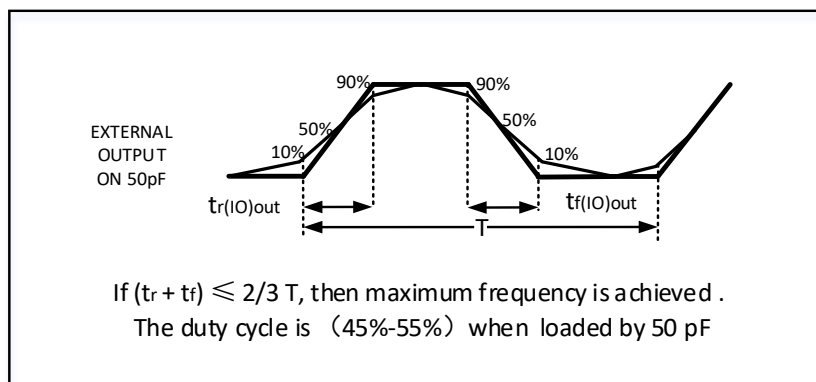
Figure 4-5. I/O port AC characteristics definition

4.12. ADC characteristics

Table 4-26. ADC characteristics

| Symbol | Parameter | Conditions | Min | Typ | Max | Unit |
|----------------------------------|--|---------------------------------|-------|------------------|-------------------|---------------------|
| V _{DDA} ⁽¹⁾ | Operating voltage | — | 2.4 | 3.3 | 3.6 | V |
| V _{IN} ⁽¹⁾ | ADC input voltage range | — | 0 | — | V _{REFP} | V |
| f _{ADC} ⁽¹⁾ | ADC clock | — | 0.1 | — | 42 | MHz |
| f _s ⁽¹⁾ | Sampling rate | 12-bit | 0.007 | — | 3 | MSPS |
| | | 10-bit | 0.008 | — | 3.5 | |
| | | 8-bit | 0.01 | — | 4.2 | |
| | | 6-bit | 0.011 | — | 5.25 | |
| V _{AIN} ⁽¹⁾ | Analog input voltage | 16 external; 2 internal | 0 | — | V _{DDA} | V |
| V _{REFP} ⁽²⁾ | Positive Reference Voltage | — | 1.8 | — | V _{DDA} | V |
| V _{REFN} ⁽²⁾ | Negative Reference Voltage | — | — | V _{SSA} | — | V |
| R _{AIN} ⁽²⁾ | External input impedance | See Equation 1 | — | — | 24 | kΩ |
| R _{ADC} ⁽²⁾ | Input sampling switch resistance | — | — | — | 0.2 | kΩ |
| C _{ADC} ⁽²⁾ | Input sampling capacitance | No pin/pad capacitance included | — | — | 5.5 | pF |
| t _{CAL} ⁽²⁾ | Calibration time | f _{ADC} = 42 MHz | — | 3.12 | — | μs |
| t _s ⁽²⁾ | Sampling time | f _{ADC} = 42 MHz | 0.036 | — | 5.7 | μs |
| t _{CONV} ⁽²⁾ | Total conversion time(including sampling time) | 12-bit | — | 14 | — | 1/ f _{ADC} |
| | | 10-bit | — | 12 | — | |
| | | 8-bit | — | 10 | — | |
| | | 6-bit | — | 8 | — | |
| t _{SU} ⁽²⁾ | Startup time | — | — | — | 1 | μs |

(1) Based on characterization, not tested in production.

(2) Guaranteed by design, not tested in production.

Equation 1: R_{AIN} max formula
$$R_{AIN} < \frac{T_s}{f_{ADC} * C_{ADC} * \ln(2^{N+2})} - R_{ADC}$$

The formula above (Equation 1) is used to determine the maximum external impedance allowed for an error below 1/4 of LSB. Here N = 12 (from 12-bit resolution).

Table 4-27. ADC R_{AIN} max for f_{ADC} = 42 MHz

| T _s (cycles) | t _s (us) | R _{AIN} max (kΩ) |
|-------------------------|---------------------|---------------------------|
| 1.5 | 0.04 | 0.47 |
| 7.5 | 0.18 | 3.15 |
| 13.5 | 0.32 | 5.82 |
| 28.5 | 0.68 | 12.55 |
| 41.5 | 0.99 | 18.35 |
| 55.5 | 1.32 | 24.55 |
| 71.5 | 1.70 | NA |

| T_s (cycles) | t_s (μ s) | R_{AINmax} (k Ω) |
|----------------|------------------|----------------------------|
| 239.5 | 5.70 | NA |

Table 4-28. ADC dynamic accuracy at $f_{ADC} = 14$ MHz⁽¹⁾

| Symbol | Parameter | Test conditions | Min | Typ | Max | Unit |
|--------|--------------------------------------|---|-----|-------|-----|------|
| ENOB | Effective number of bits | $f_{ADC} = 14$ MHz | — | 10.3 | — | bits |
| SNDR | Signal-to-noise and distortion ratio | $V_{DDA} = V_{REFP} = 3.3$ V Input Frequency = 20 kHz Temperature = 25 °C | — | 63.8 | — | dB |
| SNR | Signal-to-noise ratio | | — | 64.5 | — | |
| THD | Total harmonic distortion | | — | -67.5 | — | |

(1) Based on characterization, not tested in production.

Table 4-29. ADC dynamic accuracy at $f_{ADC} = 42$ MHz⁽¹⁾

| Symbol | Parameter | Test conditions | Min | Typ | Max | Unit |
|--------|--------------------------------------|---|-----|-------|-----|------|
| ENOB | Effective number of bits | $f_{ADC} = 42$ MHz | — | 10.3 | — | bits |
| SNDR | Signal-to-noise and distortion ratio | $V_{DDA} = V_{REFP} = 3.3$ V Input Frequency = 20 kHz Temperature = 25 °C | — | 63.8 | — | dB |
| SNR | Signal-to-noise ratio | | — | 64.5 | — | |
| THD | Total harmonic distortion | | — | -67.5 | — | |

(1) Based on characterization, not tested in production.

Table 4-30. ADC static accuracy at $f_{ADC} = 42$ MHz⁽¹⁾

| Symbol | Parameter | Test conditions | Typ | Max | Unit |
|--------|------------------------------|--|---------|-----|------|
| Offset | Offset error | $f_{ADC} = 42$ MHz $V_{DDA} = V_{REFP} = 3.3$ V | ± 1 | — | LSB |
| DNL | Differential linearity error | | ± 1 | — | |
| INL | Integral linearity error | | ± 3 | — | |

(1) Based on characterization, not tested in production.

4.13. Temperature sensor characteristics

Table 4-31. Temperature sensor characteristics⁽¹⁾

| Symbol | Parameter | Min | Typ | Max | Unit |
|------------------------------|--|-----|-----------|-----|---------|
| T_L | VSENSE linearity with temperature | — | ± 1.5 | — | °C |
| Avg_Slope | Average slope | — | 4.3 | — | mV/°C |
| V_{25} | Voltage at 25 °C | — | 1.47 | — | V |
| t_{START} | Startup time | — | — | — | μ s |
| t_{S_temp} ⁽²⁾ | ADC sampling time when reading the temperature | — | 17.1 | — | μ s |

(1) Based on characterization, not tested in production.

(2) Shortest sampling time can be determined in the application by multiple iterations.

4.14. DAC characteristics

Table 4-32. DAC characteristics

| Symbol | Parameter | Conditions | Min | Typ | Max | Unit |
|-----------------------------|---|--|------|-----------|-----------------------|---------------|
| $V_{DDA}^{(1)}$ | Operating voltage | — | 1.71 | 3.3 | 3.6 | V |
| $V_{REFP}^{(1)}$ | Reference supply voltage | — | 1.8 | — | V_{DDA} | V |
| $V_{REFN}^{(1)}$ | Negative Reference Voltage | — | — | V_{SSA} | — | V |
| $R_{LOAD}^{(2)}$ | Load resistance | Resistive load with buffer ON | 5 | — | — | k Ω |
| $R_o^{(2)}$ | Impedance output with buffer OFF | — | — | — | 15 | k Ω |
| $C_{LOAD}^{(2)}$ | Load capacitance | No pin/pad capacitance included | — | — | 50 | pF |
| DAC_OUT min ⁽²⁾ | Lower DAC_OUT voltage with buffer ON | — | 0.2 | — | — | V |
| DAC_OUT max ⁽²⁾ | Higher DAC_OUT voltage with buffer ON | — | — | — | $V_{DDA}-0.2$ | V |
| DAC_OUT min ⁽²⁾ | Lower DAC_OUT voltage with buffer OFF | — | — | 0.5 | — | mV |
| DAC_OUT max ⁽²⁾ | Higher DAC_OUT voltage with buffer OFF | — | — | — | $V_{DDA}-1\text{LSB}$ | V |
| $I_{DDA}^{(1)}$ | DAC current consumption in quiescent mode | With no load, middle code(0x800) on the input, $V_{REFP} = 3.6\text{ V}$ | — | 380 | — | μA |
| | | With no load, worst code(0xF1C) on the input, $V_{REFP} = 3.6\text{ V}$ | — | 460 | — | μA |
| $I_{DDVREFP}^{(1)}$ | DAC current consumption in quiescent mode | With no load, middle code(0x800) on the input, $V_{REFP} = 3.6\text{ V}$ | — | 120 | — | μA |
| | | With no load, worst code(0xF1C) on the input, $V_{REFP} = 3.6\text{ V}$ | — | 320 | — | μA |
| DNL ⁽¹⁾ | Differential non-linearity error | DAC in 12-bit mode | — | — | ± 3 | LSB |
| INL ⁽¹⁾ | Integral non-linearity | DAC in 12-bit mode | — | — | ± 4 | LSB |
| Offset ⁽¹⁾ | Offset error | DAC in 12-bit mode | — | — | ± 12 | LSB |
| GE ⁽¹⁾ | Gain error | DAC in 12-bit mode | — | — | ± 0.5 | % |
| $T_{\text{settling}}^{(1)}$ | Settling time | $C_{LOAD} \leq 50\text{ pF}$, $R_{LOAD} \geq 5\text{ k}\Omega$ | — | 0.3 | 1 | μs |
| $T_{\text{wakeup}}^{(2)}$ | Wakeup from off state | — | — | 5 | 10 | μs |
| Update | Max frequency for a correct | $C_{LOAD} \leq 50\text{ pF}$, $R_{LOAD} \geq 5\text{ k}\Omega$ | — | — | 4 | MS/s |

| Symbol | Parameter | Conditions | Min | Typ | Max | Unit |
|---------------------|---|------------|-----|-----|-----|------|
| rate ⁽²⁾ | DAC_OUT change from code i to i±1LSBs | | | | | |
| PSRR ⁽²⁾ | Power supply rejection ratio (to V _{DDA}) | — | 55 | 80 | — | dB |

(1) Based on characterization, not tested in production.

(2) Guaranteed by design, not tested in production.

4.15. I2C characteristics

Table 4-33. I2C characteristics⁽¹⁾⁽²⁾

| Symbol | Parameter | Conditions | Standard mode | | Fast mode | | Fast mode plus | | Unit |
|-------------------------|---|------------|------------------|------|-----------|-----|----------------|-----|------|
| | | | Min | Max | Min | Max | Min | Max | |
| t _{SCL(H)} | SCL clock high time | — | 4.0 | — | 0.6 | — | 0.2 | — | μs |
| t _{SCL(L)} | SCL clock low time | — | 4.7 | — | 1.3 | — | 0.5 | — | μs |
| t _{SU(SDA)} | SDA setup time | — | 250 | — | 100 | — | 50 | — | ns |
| t _{H(SDA)} | SDA data hold time | — | 0 ⁽³⁾ | 3450 | 0 | 900 | 0 | 450 | ns |
| t _{R(SDA/SCL)} | SDA and SCL rise time | — | — | 1000 | — | 300 | — | 120 | ns |
| t _{F(SDA/SCL)} | SDA and SCL fall time | — | — | 300 | — | 300 | — | 120 | ns |
| t _{H(STA)} | Start condition hold time | — | 4.0 | — | 0.6 | — | 0.26 | — | μs |
| t _{SU(STA)} | Repeated Start condition setup time | — | 4.7 | — | 0.6 | — | 0.26 | — | μs |
| t _{SU(STO)} | Stop condition setup time | — | 4.0 | — | 0.6 | — | 0.26 | — | μs |
| t _{BUFF} | Stop to Start condition time (bus free) | — | 4.7 | — | 1.3 | — | 0.5 | — | μs |

(1) Guaranteed by design, not tested in production

(2) To ensure the standard mode I2C frequency, f_{PCLK1} must be at least 2 MHz. To ensure the fast mode I2C frequency, f_{PCLK1} must be at least 4 MHz. To ensure the fast mode plus I2C frequency, f_{PCLK1} must be at least a multiple of 10 MHz.

(3) The device should provide a data hold time of 300 ns at least in order to bridge the undefined region of the falling edge of SCL.

Figure 4-6. I2C bus timing diagram

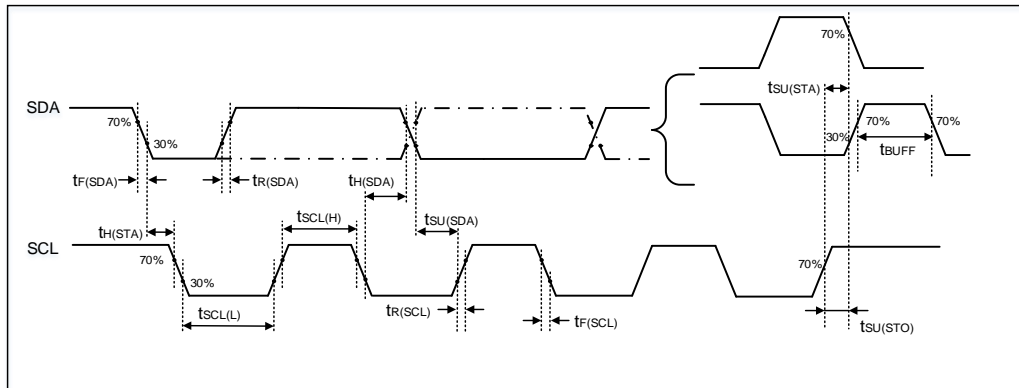

4.16. SPI characteristics

Table 4-34. Standard SPI characteristics⁽¹⁾

| Symbol | Parameter | Conditions | Min | Typ | Max | Unit |
|------------------------|--------------------------|--|-------|-------|-------|------|
| f_{SCK} | SCK clock frequency | — | — | — | 30 | MHz |
| $t_{SCK(H)}$ | SCK clock high time | Master mode, $f_{PCLKx} = 120\text{ MHz}$, presc = 8 | 31.83 | 33.33 | 34.83 | ns |
| $t_{SCK(L)}$ | SCK clock low time | Master mode, $f_{PCLKx} = 120\text{ MHz}$, presc = 8 | 31.83 | 33.33 | 34.83 | ns |
| SPI master mode | | | | | | |
| $t_{V(MO)}$ | Data output valid time | — | — | 7 | — | ns |
| $t_{H(MO)}$ | Data output hold time | — | — | 4 | — | ns |
| $t_{SU(MI)}$ | Data input setup time | — | 1 | — | — | ns |
| $t_{H(MI)}$ | Data input hold time | — | 0 | — | — | ns |
| SPI slave mode | | | | | | |
| $t_{SU(NSS)}$ | NSS enable setup time | — | 0 | — | — | ns |
| $t_{H(NSS)}$ | NSS enable hold time | — | 1 | — | — | ns |
| $t_{A(SO)}$ | Data output access time | — | — | 9 | — | ns |
| $t_{DIS(SO)}$ | Data output disable time | — | — | 8 | — | ns |
| $t_{V(SO)}$ | Data output valid time | — | — | 10 | — | ns |
| $t_{H(SO)}$ | Data output hold time | — | — | 10 | — | ns |
| $t_{SU(SI)}$ | Data input setup time | — | 0 | — | — | ns |
| $t_{H(SI)}$ | Data input hold time | — | 2 | — | — | ns |

(1) Based on characterization, not tested in production.

Figure 4-7. SPI timing diagram - master mode

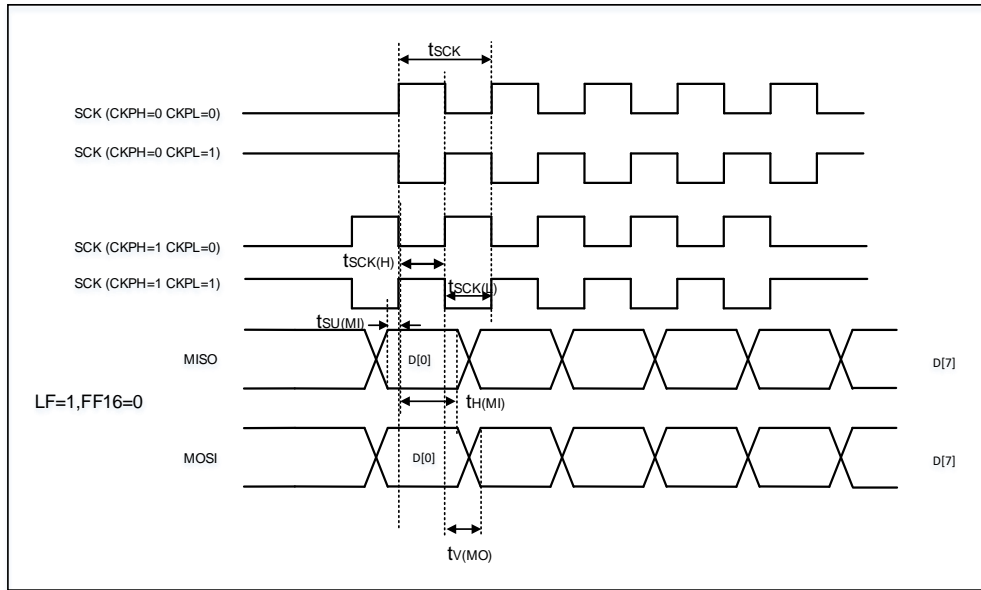
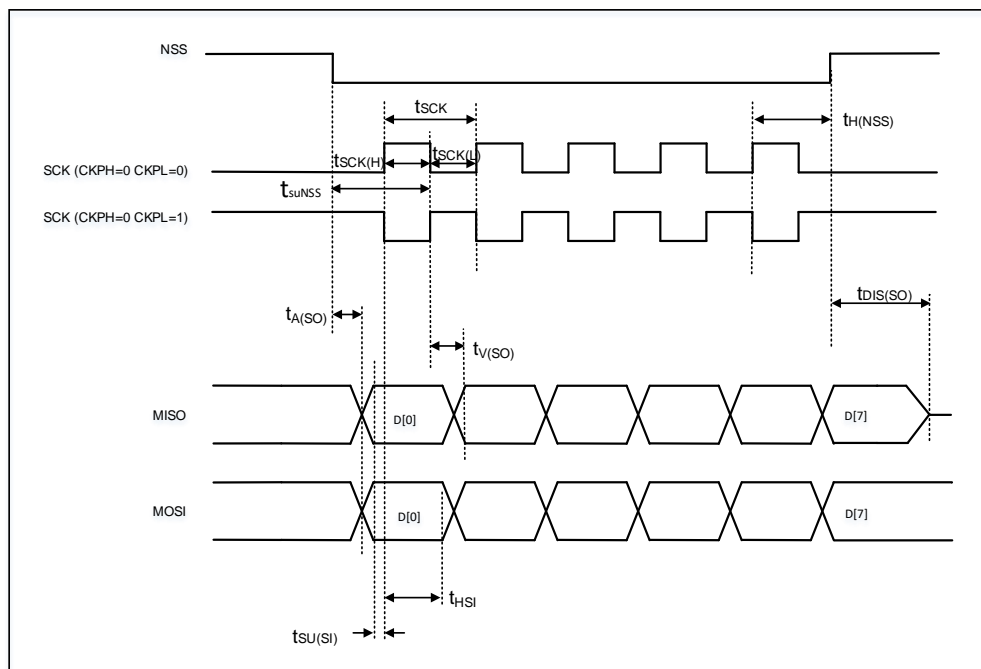

Figure 4-8. SPI timing diagram - slave mode



4.17. I2S characteristics

Table 4-35. I2S characteristics⁽¹⁾⁽²⁾

| Symbol | Parameter | Conditions | Min | Typ | Max | Unit |
|----------|-----------------|--|-----|-------|-----|------|
| f_{ck} | Clock frequency | Master mode (data: 16 bits, Audio frequency = 96 kHz) | — | 3.078 | — | MHz |

| | | | | | | |
|------------------|----------------------------------|--|---|-----|---|----|
| | | Slave mode | — | 10 | — | |
| t_H | Clock high time | — | — | 162 | — | ns |
| t_L | Clock low time | | — | 163 | — | ns |
| $t_{V(WS)}$ | WS valid time | Master mode | — | 2 | — | ns |
| $t_{H(WS)}$ | WS hold time | Master mode | — | 2 | — | ns |
| $t_{SU(WS)}$ | WS setup time | Slave mode | 0 | — | — | ns |
| $t_{H(WS)}$ | WS hold time | Slave mode | 3 | — | — | ns |
| $DuCy_{(SCK)}$ | I2S slave input clock duty cycle | Slave mode | — | 50 | — | % |
| $t_{SU(SD_MR)}$ | Data input setup time | Master mode | 0 | — | — | ns |
| $t_{SU(SD_SR)}$ | Data input setup time | Slave mode | 0 | — | — | ns |
| $t_{H(SD_MR)}$ | Data input hold time | Master receiver | 1 | — | — | ns |
| $t_{H(SD_SR)}$ | | Slave receiver | 3 | — | — | ns |
| $t_{V(SD_ST)}$ | Data output valid time | Slave transmitter (after enable edge) | — | 12 | — | ns |
| $t_{H(SD_ST)}$ | Data output hold time | Slave transmitter (after enable edge) | — | 10 | — | ns |
| $t_{V(SD_MT)}$ | Data output valid time | Master transmitter (after enable edge) | — | 10 | — | ns |
| $t_{H(SD_MT)}$ | Data output hold time | Master transmitter (after enable edge) | — | 7 | — | ns |

(1) Guaranteed by design, not tested in production.

(2) Based on characterization, not tested in production.

Figure 4-9. I2S timing diagram - master mode

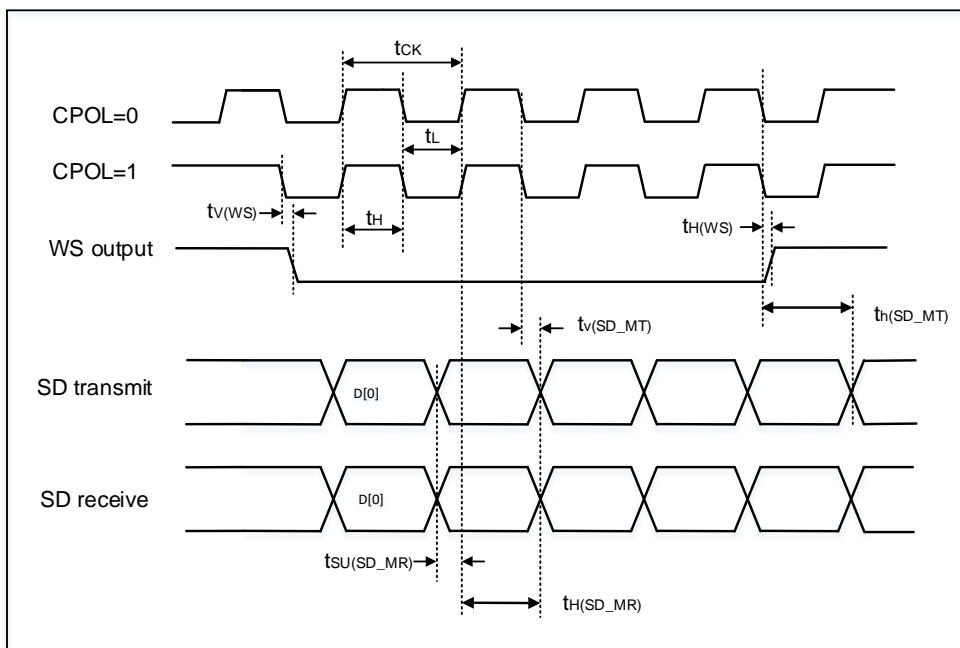
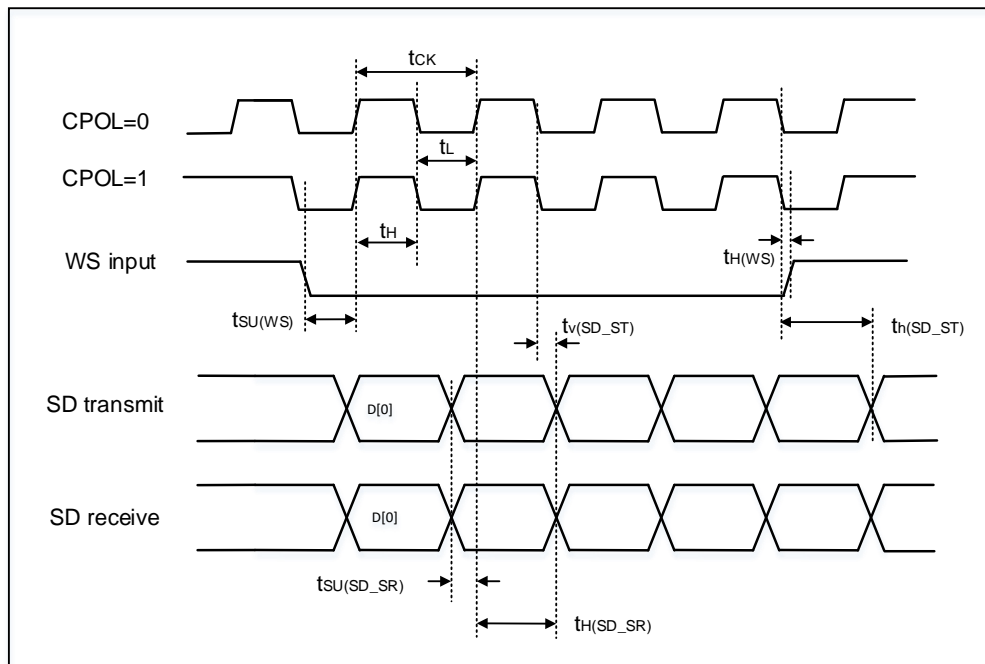

Figure 4-10. I2S timing diagram - slave mode



4.18. USART characteristics

Table 4-36. USART characteristics⁽¹⁾

| Symbol | Parameter | Conditions | Min | Typ | Max | Unit |
|--------------|---------------------|-------------------------------|-----|-----|-----|------|
| f_{SCK} | SCK clock frequency | $f_{PCLKx} = 120 \text{ MHz}$ | — | — | 60 | MHz |
| $t_{SCK(H)}$ | SCK clock high time | $f_{PCLKx} = 120 \text{ MHz}$ | 7.5 | — | — | ns |
| $t_{SCK(L)}$ | SCK clock low time | $f_{PCLKx} = 120 \text{ MHz}$ | 7.5 | — | — | ns |

(1) Guaranteed by design, not tested in production.

4.19. CAN characteristics

Refer to [Table 4-24. I/O port DC characteristics](#)⁽¹⁾ for more details on the input/output alternate function characteristics (CANTX and CANRX).

4.20. USBFS characteristics

Table 4-37. USBFS start up time

| Symbol | Parameter | Max | Unit |
|---------------------|--------------------|-----|---------------|
| $t_{STARTUP}^{(1)}$ | USBFS startup time | 1 | μs |

(1) Guaranteed by design, not tested in production.

Table 4-38. USBFS DC electrical characteristics

| Symbol | Parameter | Conditions | Min | Typ | Max | Unit | |
|--------------------------------|-----------------------|-----------------------------------|--|--------|-------|------|---|
| Input levels ⁽¹⁾ | V _{DD} | USBFS operating voltage | — | 3 | — | 3.6 | V |
| | V _{DI} | Differential input sensitivity | — | 0.2 | — | — | |
| | V _{CM} | Differential common mode range | Includes V _{DI} range | 0.8 | — | 2.5 | |
| | V _{SE} | Single ended receiver threshold | — | 1.3 | — | 2.0 | |
| Output levels ⁽²⁾ | V _{OL} | Static output level low | R _L of 1.0 kΩ to 3.6 V | — | 0.064 | 0.3 | V |
| | V _{OH} | Static output level high | R _L of 15 kΩ to V _{SS} | 2.8 | 3.3 | 3.6 | |
| R _{PD} ⁽²⁾ | PA11, PA12(USB_DM/DP) | V _{IN} = V _{DD} | 17 | 20.574 | 24 | kΩ | |
| | PA9(USB_VBUS) | | 0.65 | — | 2.0 | | |
| R _{PU} ⁽²⁾ | PA11, PA12(USB_DM/DP) | V _{IN} = V _{SS} | 1.5 | 1.585 | 2.1 | | |
| | PA9(USB_VBUS) | | 0.25 | 0.326 | 0.55 | | |

- (1) Guaranteed by design, not tested in production.
(2) Based on characterization, not tested in production.

Table 4-39. USBFS electrical characteristics⁽¹⁾

| Symbol | Parameter | Conditions | Min | Typ | Max | Unit |
|------------------|---------------------------------|--------------------------------|-----|-----|-----|------|
| t _R | Rise time | C _L = 50 pF | 4 | — | 20 | ns |
| t _F | Fall time | C _L = 50 pF | 4 | — | 20 | ns |
| t _{RFM} | Rise/fall time matching | t _R /t _F | 90 | — | 110 | % |
| V _{CRS} | Output signal crossover voltage | — | 1.3 | — | 2.0 | V |

- (1) Guaranteed by design, not tested in production.

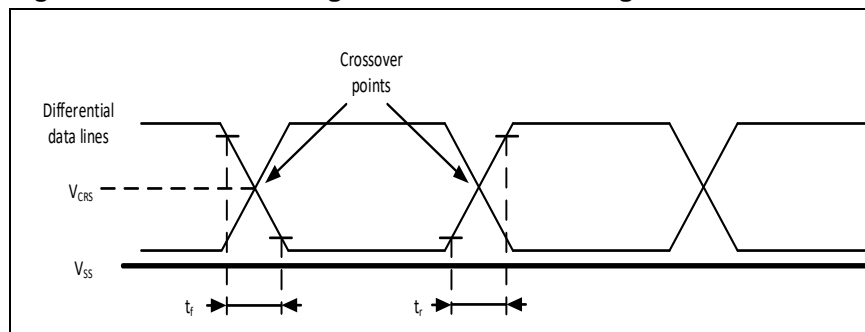
Figure 4-11. USBFS timings: definition of data signal rise and fall time

4.21. EXMC characteristics

Table 4-40. Asynchronous non-multiplexed SRAM/PSRAM/NOR read timings⁽¹⁾⁽²⁾⁽³⁾

| Symbol | Parameter | Min | Max | Unit |
|---------------------------|---|------|------|------|
| t _{w(NE)} | EXMC_NE low time | 40.5 | 42.5 | ns |
| t _{v(NOE_NE)} | EXMC_NEx low to EXMC_NOE low | 0 | — | ns |
| t _{w(NOE)} | EXMC_NOE low time | 40.5 | 42.5 | ns |
| t _{h(NE_NOE)} | EXMC_NOE high to EXMC_NE high hold time | 0 | — | ns |
| t _{v(A_NE)} | EXMC_NEx low to EXMC_A valid | 0 | — | ns |
| t _{v(BL_NE)} | EXMC_NEx low to EXMC_BL valid | 0 | — | ns |
| t _{su(DATA_NE)} | Data to EXMC_NEx high setup time | 32.2 | — | ns |
| t _{su(DATA_NOE)} | Data to EXMC_NOEx high setup time | 32.2 | — | ns |

| | | | | |
|--------------------|------------------------------------|-----|-----|----|
| $t_{h(DATA_NOE)}$ | Data hold time after EXMC_NOE high | 0 | — | ns |
| $t_{h(DATA_NE)}$ | Data hold time after EXMC_NEx high | 0 | — | ns |
| $t_{v(NADV_NE)}$ | EXMC_NEx low to EXMC_NADV low | 0 | — | ns |
| $t_{w(NADV)}$ | EXMC_NADV low time | 7.3 | 9.3 | ns |

(1) $C_L = 30$ pF.

(2) Guaranteed by design, not tested in production.

(3) Based on configure: $f_{HCLK} = 120$ MHz, AddressSetupTime = 0, AddressHoldTime = 1, DataSetupTime = 1.

Table 4-41. Asynchronous non-multiplexed SRAM/PSRAM/NOR write timings⁽¹⁾⁽²⁾⁽³⁾

| Symbol | Parameter | Min | Max | Unit |
|---------------------|---|------|------|------|
| $t_{w(NE)}$ | EXMC_NE low time | 23.9 | 25.9 | ns |
| $t_{v(NWE_NE)}$ | EXMC_NEx low to EXMC_NWE low | 7.3 | — | ns |
| $t_{w(NWE)}$ | EXMC_NWE low time | 7.3 | 9.3 | ns |
| $t_{h(NE_NWE)}$ | EXMC_NWE high to EXMC_NE high hold time | 7.3 | 9.3 | ns |
| $t_{v(A_NE)}$ | EXMC_NEx low to EXMC_A valid | 0 | — | ns |
| $t_{v(NADV_NE)}$ | EXMC_NEx low to EXMC_NADV low | 0 | — | ns |
| $t_{w(NADV)}$ | EXMC_NADV low time | 7.3 | 9.3 | ns |
| $t_{h(AD_NADV)}$ | EXMC_AD(address) valid hold time after EXMC_NADV high | 15.6 | — | ns |
| $t_{h(A_NWE)}$ | Address hold time after EXMC_NWE high | 7.3 | — | ns |
| $t_{h(BL_NWE)}$ | EXMC_BL hold time after EXMC_NWE high | 7.3 | — | ns |
| $t_{v(BL_NE)}$ | EXMC_NEx low to EXMC_BL valid | 0 | — | ns |
| $t_{v(DATA_NADV)}$ | EXMC_NADV high to DATA valid | 0 | — | ns |
| $t_{h(DATA_NWE)}$ | Data hold time after EXMC_NWE high | 7.3 | — | ns |

(1) $C_L = 30$ pF.

(2) Guaranteed by design, not tested in production.

(3) Based on configure: $f_{HCLK} = 120$ MHz, AddressSetupTime = 0, AddressHoldTime = 1, DataSetupTime = 1.

Table 4-42. Asynchronous multiplexed PSRAM/NOR read timings⁽¹⁾⁽²⁾⁽³⁾

| Symbol | Parameter | Min | Max | Unit |
|---------------------|--|------|------|------|
| $t_{w(NE)}$ | EXMC_NE low time | 57.1 | 59.1 | ns |
| $t_{v(NOE_NE)}$ | EXMC_NEx low to EXMC_NOE low | 23.9 | — | ns |
| $t_{w(NOE)}$ | EXMC_NOE low time | 32.2 | 34.2 | ns |
| $t_{h(NE_NOE)}$ | EXMC_NOE high to EXMC_NE high hold time | 0 | — | ns |
| $t_{v(A_NE)}$ | EXMC_NEx low to EXMC_A valid | 0 | — | ns |
| $t_{v(A_NOE)}$ | Address hold time after EXMC_NOE high | 0 | — | ns |
| $t_{v(BL_NE)}$ | EXMC_NEx low to EXMC_BL valid | 0 | — | ns |
| $t_{h(BL_NOE)}$ | EXMC_BL hold time after EXMC_NOE high | 0 | — | ns |
| $t_{su(DATA_NE)}$ | Data to EXMC_NEx high setup time | 33.2 | — | ns |
| $t_{su(DATA_NOE)}$ | Data to EXMC_NOEx high setup time | 33.2 | — | ns |
| $t_{h(DATA_NOE)}$ | Data hold time after EXMC_NOE high | 0 | — | ns |
| $t_{h(DATA_NE)}$ | Data hold time after EXMC_NEx high | 0 | — | ns |
| $t_{v(NADV_NE)}$ | EXMC_NEx low to EXMC_NADV low | 0 | — | ns |
| $t_{w(NADV)}$ | EXMC_NADV low time | 7.3 | 9.3 | ns |
| $T_{h(AD_NADV)}$ | EXMC_AD(adress) valid hold time after EXMC_NADV high | 7.3 | 9.3 | ns |

- (1) $C_L = 30$ pF.
- (2) Guaranteed by design, not tested in production.
- (3) Based on configure: $f_{HCLK} = 120$ MHz, AddressSetupTime = 0, AddressHoldTime = 1, DataSetUpTime = 1.

Table 4-43. Asynchronous multiplexed PSRAM/NOR write timings⁽¹⁾⁽²⁾⁽³⁾

| Symbol | Parameter | Min | Max | Unit |
|---------------------|---|------|------|------|
| $t_{w(NE)}$ | EXMC_NE low time | 40.5 | 42.5 | ns |
| $t_{v(NWE_NE)}$ | EXMC_NEx low to EXMC_NWE low | 7.3 | — | ns |
| $t_{w(NWE)}$ | EXMC_NWE low time | 23.9 | 25.9 | ns |
| $t_{h(NE_NWE)}$ | EXMC_NWE high to EXMC_NE high hold time | 7.3 | — | ns |
| $t_{v(A_NE)}$ | EXMC_NEx low to EXMC_A valid | 0 | — | ns |
| $t_{v(NADV_NE)}$ | EXMC_NEx low to EXMC_NADV low | 0 | — | ns |
| $t_{w(NADV)}$ | EXMC_NADV low time | 7.3 | 9.3 | ns |
| $t_{h(AD_NADV)}$ | EXMC_AD(address) valid hold time after EXMC_NADV high | 7.3 | — | ns |
| $t_{h(A_NWE)}$ | Address hold time after EXMC_NWE high | 7.3 | — | ns |
| $t_{h(BL_NWE)}$ | EXMC_BL hold time after EXMC_NWE high | 7.3 | — | ns |
| $t_{v(BL_NE)}$ | EXMC_NEx low to EXMC_BL valid | 0 | — | ns |
| $t_{v(DATA_NADV)}$ | EXMC_NADV high to DATA valid | 7.3 | — | ns |
| $t_{h(DATA_NWE)}$ | Data hold time after EXMC_NWE high | 7.3 | — | ns |

- (1) $C_L = 30$ pF.
- (2) Guaranteed by design, not tested in production.
- (3) Based on configure: $f_{HCLK} = 120$ MHz, AddressSetupTime = 0, AddressHoldTime = 1, DataSetUpTime = 1.

Table 4-44. Synchronous multiplexed PSRAM/NOR read timings⁽¹⁾⁽²⁾⁽³⁾

| Symbol | Parameter | Min | Max | Unit |
|---------------------|----------------------------------|------|-----|------|
| $t_{w(CLK)}$ | EXMC_CLK period | 33.2 | — | ns |
| $t_{d(CLKL-NExL)}$ | EXMC_CLK low to EXMC_NEx low | 0 | — | ns |
| $t_{d(CLKH-NExH)}$ | EXMC_CLK high to EXMC_NEx high | 15.6 | — | ns |
| $t_{d(CLKL-NADVl)}$ | EXMC_CLK low to EXMC_NADV low | 0 | — | ns |
| $t_{d(CLKL-NADVh)}$ | EXMC_CLK low to EXMC_NADV high | 0 | — | ns |
| $t_{d(CLKL-Av)}$ | EXMC_CLK low to EXMC_Ax valid | 0 | — | ns |
| $t_{d(CLKH-Aiv)}$ | EXMC_CLK high to EXMC_Ax invalid | 15.6 | — | ns |
| $t_{d(CLKL-NOEL)}$ | EXMC_CLK low to EXMC_NOE low | 0 | — | ns |
| $t_{d(CLKH-NOEH)}$ | EXMC_CLK high to EXMC_NOE high | 15.6 | — | ns |
| $t_{d(CLKL-ADV)}$ | EXMC_CLK low to EXMC_AD valid | 0 | — | ns |
| $t_{d(CLKL-ADIV)}$ | EXMC_CLK low to EXMC_AD invalid | 0 | — | ns |

- (1) $C_L = 30$ pF.
- (2) Guaranteed by design, not tested in production.
- (3) Based on configure: $f_{HCLK} = 120$ MHz, BurstAccessMode = Enable; MemoryType = PSRAM; WriteBurst = Enable; CLKDivision = 3 (EXMC_CLK is 4 divided by HCLK); DataLatency = 1.

Table 4-45. Synchronous multiplexed PSRAM write timings⁽¹⁾⁽²⁾⁽³⁾

| Symbol | Parameter | Min | Max | Unit |
|--------------------|------------------------------|------|-----|------|
| $t_{w(CLK)}$ | EXMC_CLK period | 33.2 | — | ns |
| $t_{d(CLKL-NExL)}$ | EXMC_CLK low to EXMC_NEx low | 0 | — | ns |

| | | | | |
|----------------------|--|------|---|----|
| $t_{d(CLKH-NExH)}$ | EXMC_CLK high to EXMC_NEx high | 15.6 | — | ns |
| $t_{d(CLKL-NADV L)}$ | EXMC_CLK low to EXMC_NADV low | 0 | — | ns |
| $t_{d(CLKL-NADV H)}$ | EXMC_CLK low to EXMC_NADV high | 0 | — | ns |
| $t_{d(CLKL-AV)}$ | EXMC_CLK low to EXMC_Ax valid | 0 | — | ns |
| $t_{d(CLKH-AIV)}$ | EXMC_CLK high to EXMC_Ax invalid | 15.6 | — | ns |
| $t_{d(CLKL-NWEL)}$ | EXMC_CLK low to EXMC_NWE low | 0 | — | ns |
| $t_{d(CLKH-NWEH)}$ | EXMC_CLK high to EXMC_NWE high | 15.6 | — | ns |
| $t_{d(CLKL-ADIV)}$ | EXMC_CLK low to EXMC_AD invalid | 0 | — | ns |
| $t_{d(CLKL-DATA)}$ | EXMC_A/D valid data after EXMC_CLK low | 0 | — | ns |
| $t_{h(CLKL-NBLH)}$ | EXMC_CLK low to EXMC_NBL high | 0 | — | ns |

- (1) $C_L = 30$ pF.
- (2) Guaranteed by design, not tested in production.
- (3) Based on configure: $f_{HCLK} = 120$ MHz, BurstAccessMode = Enable; MemoryType = PSRAM; WriteBurst = Enable; CLKDivision = 3 (EXMC_CLK is 4 divided by HCLK); DataLatency = 1.

Table 4-46. Synchronous non-multiplexed PSRAM/NOR read timings⁽¹⁾⁽²⁾⁽³⁾

| Symbol | Parameter | Min | Max | Unit |
|----------------------|----------------------------------|------|-----|------|
| $t_{w(CLK)}$ | EXMC_CLK period | 33.2 | — | ns |
| $t_{d(CLKL-NExL)}$ | EXMC_CLK low to EXMC_NEx low | 0 | — | ns |
| $t_{d(CLKH-NExH)}$ | EXMC_CLK high to EXMC_NEx high | 15.6 | — | ns |
| $t_{d(CLKL-NADV L)}$ | EXMC_CLK low to EXMC_NADV low | 0 | — | ns |
| $t_{d(CLKL-NADV H)}$ | EXMC_CLK low to EXMC_NADV high | 0 | — | ns |
| $t_{d(CLKL-AV)}$ | EXMC_CLK low to EXMC_Ax valid | 0 | — | ns |
| $t_{d(CLKH-AIV)}$ | EXMC_CLK high to EXMC_Ax invalid | 15.6 | — | ns |
| $t_{d(CLKL-NOEL)}$ | EXMC_CLK low to EXMC_NOE low | 0 | — | ns |
| $t_{d(CLKH-NOEH)}$ | EXMC_CLK high to EXMC_NOE high | 15.6 | — | ns |

- (1) $C_L = 30$ pF.
- (2) Guaranteed by design, not tested in production.
- (3) Based on configure: $f_{HCLK} = 120$ MHz, BurstAccessMode = Enable; MemoryType = PSRAM; WriteBurst = Enable; CLKDivision = 3 (EXMC_CLK is 4 divided by HCLK); DataLatency = 1.

Table 4-47. Synchronous non-multiplexed PSRAM write timings⁽¹⁾⁽²⁾⁽³⁾

| Symbol | Parameter | Min | Max | Unit |
|----------------------|--|------|-----|------|
| $t_{w(CLK)}$ | EXMC_CLK period | 33.2 | — | ns |
| $t_{d(CLKL-NExL)}$ | EXMC_CLK low to EXMC_NEx low | 0 | — | ns |
| $t_{d(CLKH-NExH)}$ | EXMC_CLK high to EXMC_NEx high | 15.6 | — | ns |
| $t_{d(CLKL-NADV L)}$ | EXMC_CLK low to EXMC_NADV low | 0 | — | ns |
| $t_{d(CLKL-NADV H)}$ | EXMC_CLK low to EXMC_NADV high | 0 | — | ns |
| $t_{d(CLKL-AV)}$ | EXMC_CLK low to EXMC_Ax valid | 0 | — | ns |
| $t_{d(CLKH-AIV)}$ | EXMC_CLK high to EXMC_Ax invalid | 15.6 | — | ns |
| $t_{d(CLKL-NWEL)}$ | EXMC_CLK low to EXMC_NWE low | 0 | — | ns |
| $t_{d(CLKH-NWEH)}$ | EXMC_CLK high to EXMC_NWE high | 15.6 | — | ns |
| $t_{d(CLKL-DATA)}$ | EXMC_A/D valid data after EXMC_CLK low | 0 | — | ns |
| $t_{h(CLKL-NBLH)}$ | EXMC_CLK low to EXMC_NBL high | 0 | — | ns |

- (1) $C_L = 30$ pF.
- (2) Guaranteed by design, not tested in production.

(3) Based on configure: $f_{HCLK} = 120$ MHz, BurstAccessMode = Enable; MemoryType = PSRAM; WriteBurst = Enable; CLKDivision = 3(EXMC_CLK is 4 divided by HCLK); DataLatency = 1.

4.22. TIMER characteristics

Table 4-48. TIMER characteristics⁽¹⁾

| Symbol | Parameter | Conditions | Min | Max | Unit |
|------------------|---|---------------------------|--------|----------------------|-----------------|
| t_{res} | Timer resolution time | — | 1 | — | $t_{TIMERxCLK}$ |
| | | $f_{TIMERxCLK} = 120$ MHz | 8.4 | — | ns |
| f_{EXT} | Timer external clock frequency | — | 0 | $f_{TIMERxCLK}/2$ | MHz |
| | | $f_{TIMERxCLK} = 120$ MHz | 0 | 60 | MHz |
| RES | Timer resolution | — | — | 16 | bit |
| $t_{COUNTER}$ | 16-bit counter clock period when internal clock is selected | — | 1 | 65536 | $t_{TIMERxCLK}$ |
| | | $f_{TIMERxCLK} = 120$ MHz | 0.0084 | 546 | μ s |
| t_{MAX_COUNT} | Maximum possible count | — | — | 65536×65536 | $t_{TIMERxCLK}$ |
| | | $f_{TIMERxCLK} = 120$ MHz | — | 35.7 | s |

(1) Guaranteed by design, not tested in production.

4.23. WDG_T characteristics

Table 4-49. FWDGT min/max timeout period at 40 kHz (IRC40K)⁽¹⁾

| Prescaler divider | PSC[2:0] bits | Min timeout RLD[11:0] = 0x000 | Max timeout RLD[11:0] = 0xFFF | Unit |
|-------------------|---------------|-------------------------------|-------------------------------|------|
| 1/4 | 000 | 0.025 | 409.525 | ms |
| 1/8 | 001 | 0.025 | 819.025 | |
| 1/16 | 010 | 0.025 | 1638.025 | |
| 1/32 | 011 | 0.025 | 3276.025 | |
| 1/64 | 100 | 0.025 | 6552.025 | |
| 1/128 | 101 | 0.025 | 13104.025 | |
| 1/256 | 110 or 111 | 0.025 | 26208.025 | |

(1) Guaranteed by design, not tested in production.

Table 4-50. WWDGT min-max timeout value at 60 MHz (f_{PCLK1})⁽¹⁾

| Prescaler divider | PSC[1:0] | Min timeout value CNT[6:0] = 0x40 | Unit | Max timeout value CNT[6:0] = 0x7F | Unit |
|-------------------|----------|-----------------------------------|---------|-----------------------------------|------|
| 1/1 | 00 | 68.2 | μ s | 4.3 | ms |
| 1/2 | 01 | 136.4 | | 8.6 | |
| 1/4 | 10 | 272.8 | | 17.2 | |
| 1/8 | 11 | 545.6 | | 34.4 | |

(1) Guaranteed by design, not tested in production.

4.24. Parameter conditions

Unless otherwise specified, all values given for $V_{DD} = V_{DDA} = 3.3\text{ V}$, $T_A = 25\text{ }^\circ\text{C}$.

5. Package information

5.1. LQFP100 package outline dimensions

Figure 5-1. LQFP100 package outline

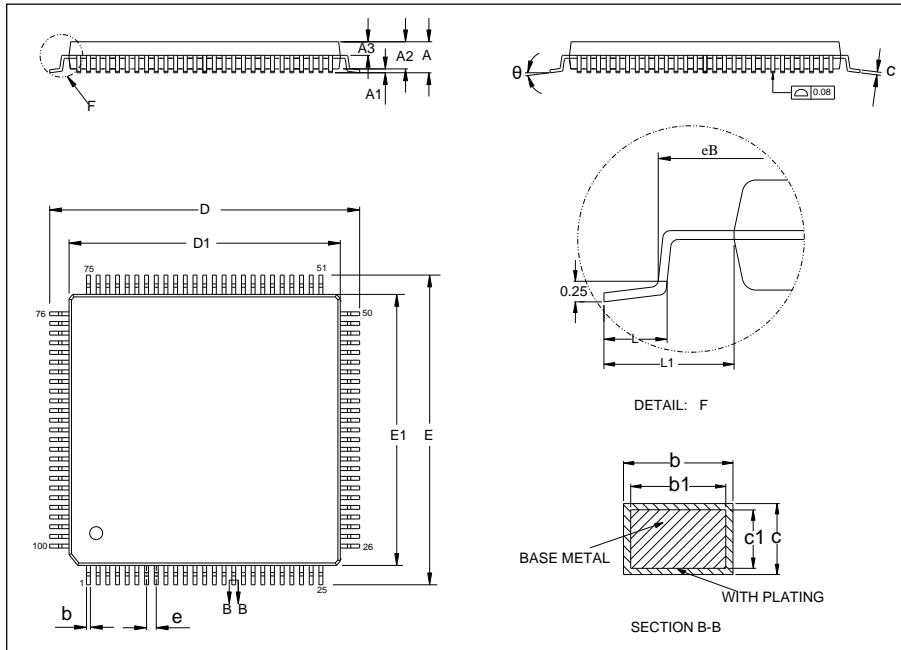
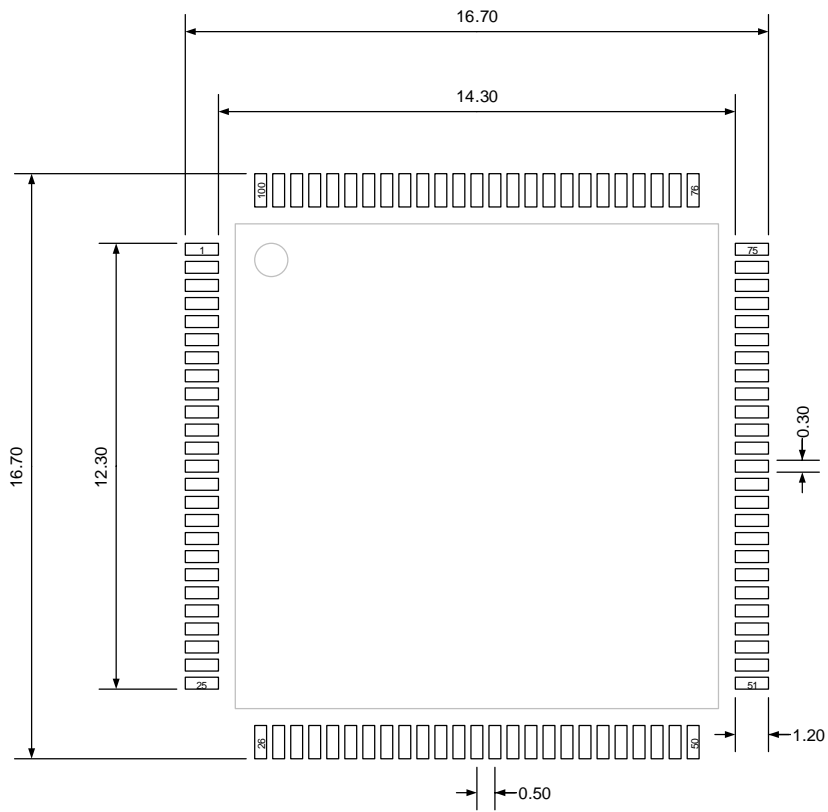

Table 5-1. LQFP100 package dimensions

| Symbol | Min | Typ | Max |
|----------|-------|-------|-------|
| A | — | — | 1.60 |
| A1 | 0.05 | — | 0.15 |
| A2 | 1.35 | 1.40 | 1.45 |
| A3 | 0.59 | 0.64 | 0.69 |
| b | 0.18 | — | 0.26 |
| b1 | 0.17 | 0.20 | 0.23 |
| c | 0.13 | — | 0.17 |
| c1 | 0.12 | 0.13 | 0.14 |
| D | 15.80 | 16.00 | 16.20 |
| D1 | 13.90 | 14.00 | 14.10 |
| E | 15.80 | 16.00 | 16.20 |
| E1 | 13.90 | 14.00 | 14.10 |
| e | — | 0.50 | — |
| eB | 15.05 | — | 15.35 |
| L | 0.45 | — | 0.75 |
| L1 | — | 1.00 | — |
| θ | 0° | — | 7° |

(Original dimensions are in millimeters)

Figure 5-2. LQFP100 recommended footprint



(Original dimensions are in millimeters)

5.2. LQFP64 package outline dimensions

Figure 5-3. LQFP64 package outline

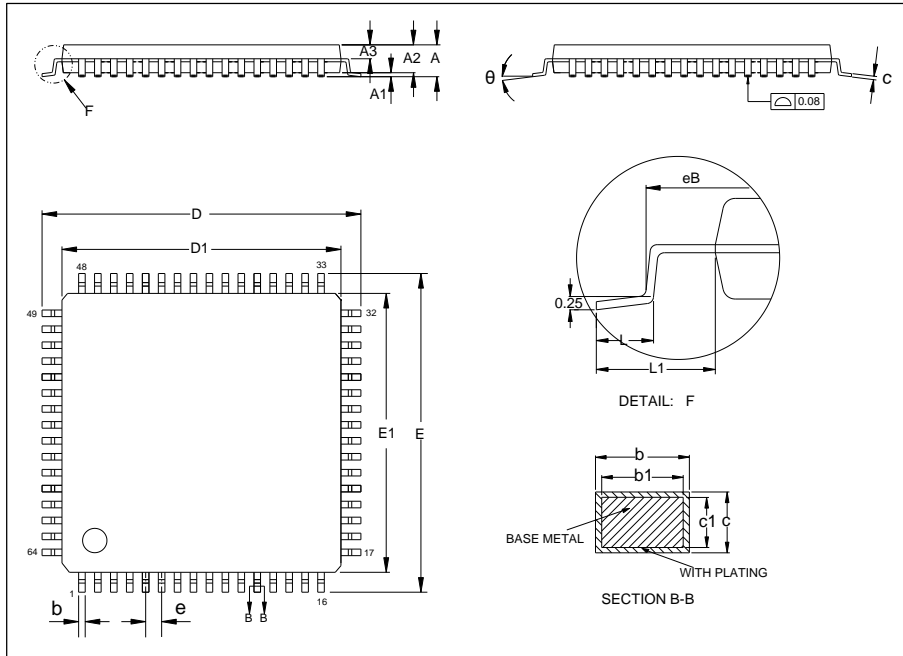
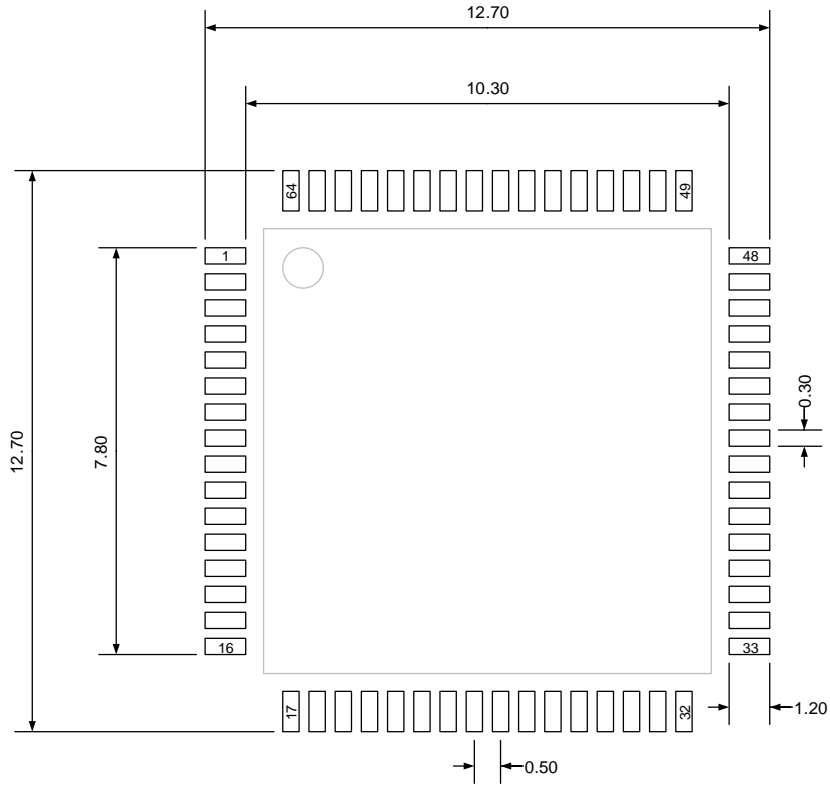

Table 5-2. LQFP64 package dimensions

| Symbol | Min | Typ | Max |
|----------|-------|-------|-------|
| A | — | — | 1.60 |
| A1 | 0.05 | — | 0.15 |
| A2 | 1.35 | 1.40 | 1.45 |
| A3 | 0.59 | 0.64 | 0.69 |
| b | 0.18 | — | 0.26 |
| b1 | 0.17 | 0.20 | 0.23 |
| c | 0.13 | — | 0.17 |
| c1 | 0.12 | 0.13 | 0.14 |
| D | 11.80 | 12.00 | 12.20 |
| D1 | 9.90 | 10.00 | 10.10 |
| E | 11.80 | 12.00 | 12.20 |
| E1 | 9.90 | 10.00 | 10.10 |
| e | — | 0.50 | — |
| eB | 11.25 | — | 11.45 |
| L | 0.45 | — | 0.75 |
| L1 | — | 1.00 | — |
| θ | 0° | — | 7° |

(Original dimensions are in millimeters)

Figure 5-4. LQFP64 recommended footprint



(Original dimensions are in millimeters)

5.3. LQFP48 package outline dimensions

Figure 5-5. LQFP48 package outline

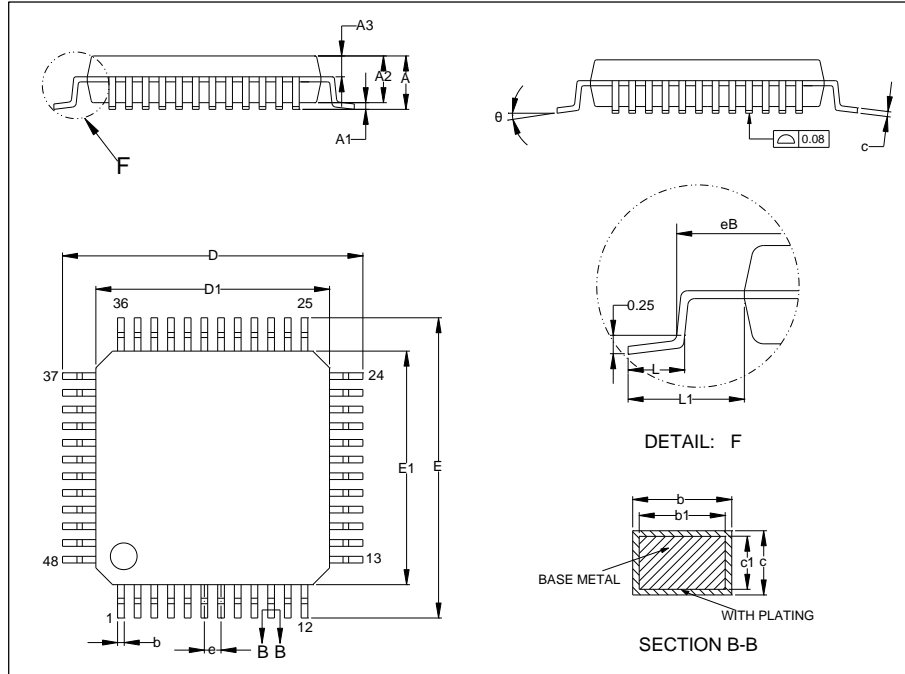
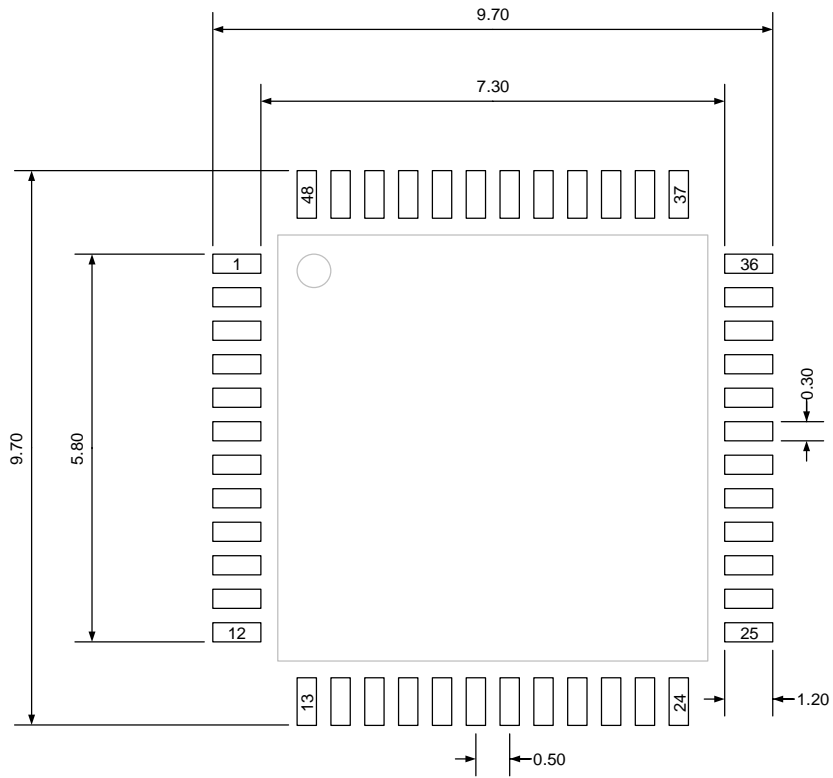

Table 5-3. LQFP48 package dimensions

| Symbol | Min | Typ | Max |
|----------|------|------|------|
| A | — | — | 1.60 |
| A1 | 0.05 | — | 0.15 |
| A2 | 1.35 | 1.40 | 1.45 |
| A3 | 0.59 | 0.64 | 0.69 |
| b | 0.18 | — | 0.26 |
| b1 | 0.17 | 0.20 | 0.23 |
| c | 0.13 | — | 0.17 |
| c1 | 0.12 | 0.13 | 0.14 |
| D | 8.80 | 9.00 | 9.20 |
| D1 | 6.90 | 7.00 | 7.10 |
| E | 8.80 | 9.00 | 9.20 |
| E1 | 6.90 | 7.00 | 7.10 |
| e | — | 0.50 | — |
| eB | 8.10 | — | 8.25 |
| L | 0.45 | — | 0.75 |
| L1 | — | 1.00 | — |
| θ | 0° | — | 7° |

(Original dimensions are in millimeters)

Figure 5-6. LQFP48 recommended footprint



(Original dimensions are in millimeters)

5.4. QFN36 package outline dimensions

Figure 5-7. QFN36 package outline

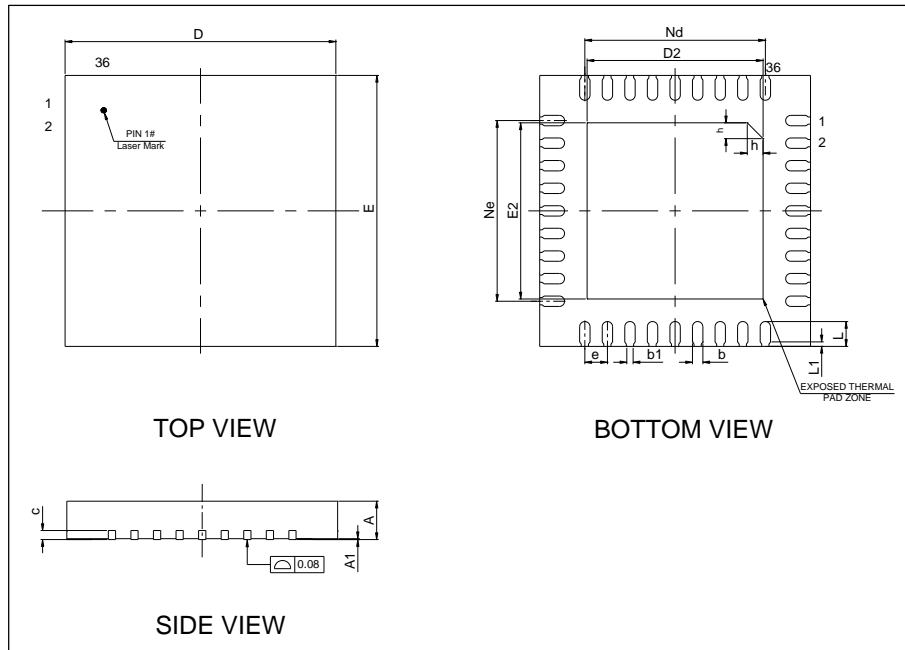
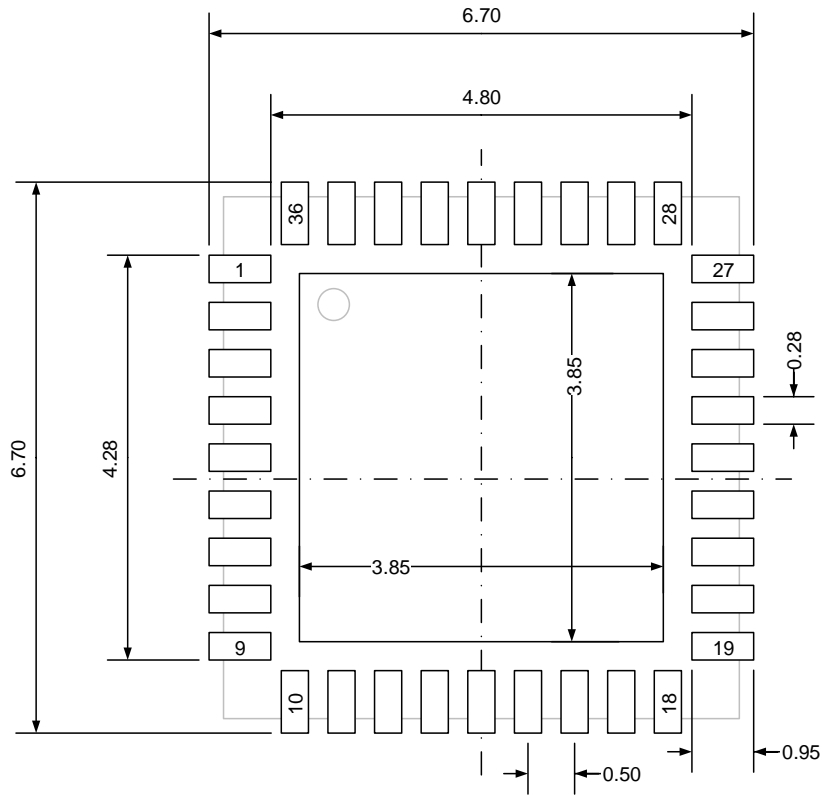

Table 5-4. QFN36 package dimensions

| Symbol | Min | Typ | Max |
|--------|------|------|------|
| A | 0.80 | 0.85 | 0.90 |
| A1 | 0 | 0.02 | 0.05 |
| b | 0.18 | 0.23 | 0.30 |
| b1 | — | 0.16 | — |
| c | 0.18 | 0.20 | 0.23 |
| D | 5.90 | 6.00 | 6.10 |
| D2 | 3.80 | 3.90 | 4.00 |
| E | 5.90 | 6.00 | 6.10 |
| E2 | 3.80 | 3.90 | 4.00 |
| e | — | 0.50 | — |
| h | 0.30 | 0.35 | 0.40 |
| L | 0.50 | 0.55 | 0.60 |
| L1 | — | 0.10 | — |
| Nd | 3.95 | 4.00 | 4.05 |
| Ne | 3.95 | 4.00 | 4.05 |

(Original dimensions are in millimeters)

Figure 5-8. QFN36 recommended footprint



(Original dimensions are in millimeters)

5.5. Thermal characteristics

Thermal resistance is used to characterize the thermal performance of the package device, which is represented by the Greek letter “ θ ”. For semiconductor devices, thermal resistance represents the steady-state temperature rise of the chip junction due to the heat dissipated on the chip surface.

θ_{JA} : Thermal resistance, junction-to-ambient.

θ_{JB} : Thermal resistance, junction-to-board.

θ_{JC} : Thermal resistance, junction-to-case.

Ψ_{JB} : Thermal characterization parameter, junction-to-board.

Ψ_{JT} : Thermal characterization parameter, junction-to-top center.

$$\theta_{JA}=(T_J-T_A)/P_D \quad (5-1)$$

$$\theta_{JB}=(T_J-T_B)/P_D \quad (5-2)$$

$$\theta_{JC}=(T_J-T_C)/P_D \quad (5-3)$$

Where, T_J = Junction temperature.

T_A = Ambient temperature

T_B = Board temperature

T_C = Case temperature which is monitoring on package surface

P_D = Total power dissipation

θ_{JA} represents the resistance of the heat flows from the heating junction to ambient air. It is an indicator of package heat dissipation capability. Lower θ_{JA} can be considerate as better overall thermal performance. θ_{JA} is generally used to estimate junction temperature.

θ_{JB} is used to measure the heat flow resistance between the chip surface and the PCB board.

θ_{JC} represents the thermal resistance between the chip surface and the package top case. θ_{JC} is mainly used to estimate the heat dissipation of the system (using heat sink or other heat dissipation methods outside the device package).

Table 5-5. Package thermal characteristics⁽¹⁾

| Symbol | Condition | Package | Value | Unit |
|---------------|------------------------------|---------|-------|------|
| θ_{JA} | Natural convection, 2S2P PCB | LQFP100 | 49.18 | °C/W |
| | | LQFP64 | 54.57 | |
| | | LQFP48 | 69.64 | |
| | | QFN36 | 36.82 | |
| θ_{JB} | Cold plate, 2S2P PCB | LQFP100 | 22.70 | °C/W |
| | | LQFP64 | 35.08 | |
| | | LQFP48 | 43.16 | |

| Symbol | Condition | Package | Value | Unit |
|---------------|------------------------------|---------|-------|------|
| | | QFN36 | 9.79 | |
| θ_{JC} | Cold plate, 2S2P PCB | LQFP100 | 12.52 | °C/W |
| | | LQFP64 | 18.11 | |
| | | LQFP48 | 25.36 | |
| | | QFN36 | 13.31 | |
| Ψ_{JB} | Natural convection, 2S2P PCB | LQFP100 | 32.85 | °C/W |
| | | LQFP64 | 35.41 | |
| | | LQFP48 | 47.75 | |
| | | QFN36 | 9.87 | |
| Ψ_{JT} | Natural convection, 2S2P PCB | LQFP100 | 0.53 | °C/W |
| | | LQFP64 | 1.10 | |
| | | LQFP48 | 2.45 | |
| | | QFN36 | 0.43 | |

(1) Thermal characteristics are based on simulation, and meet JEDEC specification.

6. Ordering information

Table 6-1. Part ordering code for GD32A103xx devices

| Ordering code | Flash (KB) | Package | Package type | Temperature operating range |
|---------------|------------|---------|--------------|---------------------------------|
| GD32A103VBT7 | 128 | LQFP100 | Green | Automotive -40 °C to +105 °C |
| GD32A103RBT7 | 128 | LQFP64 | Green | Automotive -40 °C to +105 °C |
| GD32A103CBT7 | 128 | LQFP48 | Green | Automotive -40 °C to +105 °C |
| GD32A103TBU7 | 128 | QFN36 | Green | Automotive -40 °C to +105 °C |

7. Revision history

Table 7-1. Revision history

| Revision No. | Description | Date |
|--------------|-----------------|---------------|
| 1.0 | Initial Release | Jun. 23, 2024 |

Important Notice

This document is the property of GigaDevice Semiconductor Inc. and its subsidiaries (the "Company"). This document, including any product of the Company described in this document (the "Product"), is owned by the Company under the intellectual property laws and treaties of the People's Republic of China and other jurisdictions worldwide. The Company reserves all rights under such laws and treaties and does not grant any license under its patents, copyrights, trademarks, or other intellectual property rights. The names and brands of third party referred thereto (if any) are the property of their respective owner and referred to for identification purposes only.

The Company makes no warranty of any kind, express or implied, with regard to this document or any Product, including, but not limited to, the implied warranties of merchantability and fitness for a particular purpose. The Company does not assume any liability arising out of the application or use of any Product described in this document. Any information provided in this document is provided only for reference purposes. It is the responsibility of the user of this document to properly design, program, and test the functionality and safety of any application made of this information and any resulting product. Except for customized products which has been expressly identified in the applicable agreement, the Products are designed, developed, and/or manufactured for ordinary business, industrial, personal, and/or household applications only. The Products are not designed, intended, or authorized for use as components in systems designed or intended for the operation of weapons, weapons systems, nuclear installations, atomic energy control instruments, combustion control instruments, airplane or spaceship instruments, transportation instruments, traffic signal instruments, life-support devices or systems, other medical devices or systems (including resuscitation equipment and surgical implants), pollution control or hazardous substances management, or other uses where the failure of the device or Product could cause personal injury, death, property or environmental damage ("Unintended Uses"). Customers shall take any and all actions to ensure using and selling the Products in accordance with the applicable laws and regulations. The Company is not liable, in whole or in part, and customers shall and hereby do release the Company as well as its suppliers and/or distributors from any claim, damage, or other liability arising from or related to all Unintended Uses of the Products. Customers shall indemnify and hold the Company as well as its suppliers and/or distributors harmless from and against all claims, costs, damages, and other liabilities, including claims for personal injury or death, arising from or related to any Unintended Uses of the Products.

Information in this document is provided solely in connection with the Products. The Company reserves the right to make changes, corrections, modifications or improvements to this document and Products and services described herein at any time, without notice.